



LEUCOS®



White, light and bright are the authentic expression of modernity, and for fifty-five years they've embodied the desire to reinterpret the world, the courage to show new ways, and the ambition to dress the living space

Bianco, chiaro, lucente come autentica espressione di modernità, rappresentano da cinquantacinque anni il desiderio di interpretare il mondo, il coraggio di indicare nuove strade, l'ambizione di vestire gli spazi della vita quotidiana

A handwritten signature in blue ink, appearing to read 'Renzo Angiolini', is positioned below the Italian text.

# LEUCOS

lèuco - [dal gr. λευκός «bianco»]

Nel significato profondo del termine greco antico *leuco* è racchiusa la vocazione di un'impresa, la qualità di una collezione di oggetti luminosi in equilibrio costante tra una sapiente tradizione e un innovativo design. Un dittico di significati che può essere tradotto altrimenti dalla virtuosa relazione tra conoscenze consolidate nel tempo, come l'arte veneziana della lavorazione del vetro, e nuove capacità illuminotecniche rivolte ad uno sguardo verso il futuro prossimo con l'orizzonte indirizzato dal prefisso leuco che nella terminologia ellenica schiariva ogni parola che prefissava. Bianco, chiaro, lucente come autentica espressione di modernità, rappresentano da cinquantacinque anni il desiderio di interpretare il mondo, il coraggio di indicare nuove strade, l'ambizione di vestire gli spazi della vita quotidiana. La luminosità, come preludio degli oggetti prodotti, rischiarava una modalità di pensiero che anticipa i tempi con la pazienza di chi non rincorre mode e chimere, con la consapevolezza di riuscire ad indicare uno stile, con la sicurezza di chi investe nel tempo per verificare la costanza dei risultati. Collezione di collezioni più che oggetti singoli, approfondite e qualificate varianti, famiglie di luci e bagliori più che lampade ci piace pensare di produrre materiali d'affezione per gli ambienti più domestici e familiari come per i luoghi più rappresentativi ed eleganti.

The deep meaning of the ancient Greek word *leuco* contains a company's mission and the quality of a collection of lighting objects that have found the right balance between tradition and innovative design. This double meaning can be otherwise translated by the virtuous relationship between an established knowledge, such the Venetian art of glassmaking, and a glimpse into the future; the horizon is defined by the prefix leuco (white, colourless, lighter in colour), which in ancient Greek terminology was used to "lighten" the words it was attached to. White, light and bright are the authentic expression of modernity, and for fifty-five years they've embodied the desire to reinterpret the world, the courage to show new ways, and the ambition to dress the living space. Just like the prefix, the objects we manufacture cast a light on a way of thinking that is ahead of time and shows the patience of those who don't run after fashions or delusions because they know they're creating something that will last long. And the basis for this confidence is provided by the time spent to verify the consistency of the results. Rather than a collection of individual objects, this is a collection of collections. Variants are qualified and well thought out, and form families of lights and glares. We like to think that, rather than lamps, we produce objects of affection that are suitable both for domestic and home environments, and for more formal and elegant spaces.



TRIGONA by LEUCOS

# INDEX



<u>09</u>	<u>TRIGONA</u>
<u>13</u>	<u>AELLA t</u>
<u>14</u>	<u>AELLA s</u>
<u>16</u>	<u>AELLA mini p-s</u>
<u>19</u>	<u>AELLA mini t</u>
<u>23</u>	<u>FAIRY LED s</u>
<u>25</u>	<u>FAIRY LED t</u>
<u>26</u>	<u>VOLTA</u>
<u>31</u>	<u>LEVA</u>
<u>35</u>	<u>IXI-O</u>
<u>36</u>	<u>O-LOOP</u>
<u>38</u>	<u>JJ</u>
<u>45</u>	<u>SCHEDE TECNICHE</u>
	<u>DATA SHEETS</u>



# TRIGONA

design danilo de rossi - 2015



tre diffusori sovrapposti  
three nested diffusers

*Trigona* ha l'accento sulla prima vocale. Il suo nome, come la sostanza della sua forma, dipende matematicamente dal numero tre che rappresenta la somma dei differenti possibili modi d'illuminazione che la lampada produce. Il numero perfetto, così caro a Pitagora, indica la successione degli strati sottili e resistenti in vetro borosilicato soffiato che nella loro composizione si sovrappongono concentrici mostrando ognuno la propria qualità cromatica. Satinati o trasparenti, preziosi in oro o titanio, colorati in nero o bordeaux, la sequenza dei cilindri, conici svasati verso l'esterno, permette alla sospensione di costruire differenti scenari di illuminazione attraverso i tre diffusori sovrapposti capaci di accentare differenti atmosfere luminose. Illuminare e illuminarsi è il carattere primo di questa pluripremiata lampada sollevata nello spazio dalla combinazione di luce e riflessi ricercati.

*Trigona* is pronounced with the accent on the first syllable. Both the name and the shape of this pendant lamp are mathematically derived from the number three, which represents the sum of the different types of light you can obtain. The perfect number dear to Pythagoras also indicates the number of layers of blown borosilicate glass that compose this lamp. Thin and yet robust, they overlap in concentric circles showing off various color and finish: white fading into clear, gold, titanium grey, black or burgundy red. The three nested diffusers flare out towards the rim and allow you to choose among different lighting levels, depending on the atmosphere you want to create. This award-winning suspension lamp is designed to brighten up your home environment with a combination of light and refined glows.



This award-winning suspension lamp is designed to brighten up your home environment with a combination of light and refined glows



bianco sfumato-oro/fading white-gold

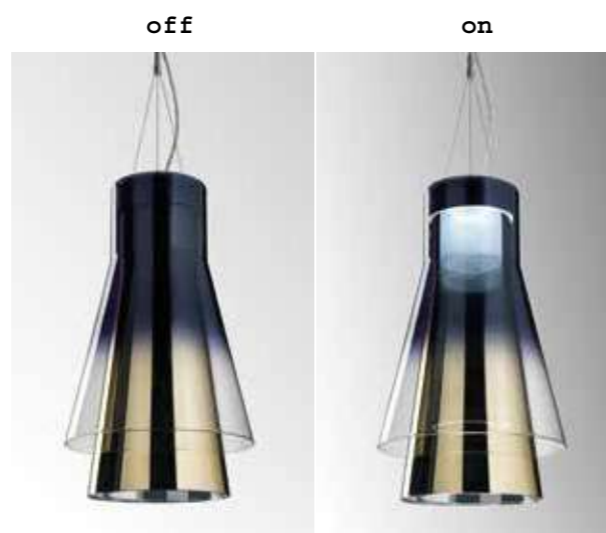

nero sfumato-oro/fading black-gold



bianco sfumato-bordeaux/fading white-bordeaux



nero sfumato-bordeaux/fading black-bordeaux



bianco sfumato-grigio titanio/fading white-titanium grey



nero sfumato-grigio titanio/fading black-titanium grey



Illuminare e illuminarsi è il carattere primo di questa pluripremiata lampada sollevata nello spazio dalla combinazione di luce e riflessi ricercati

\*nuova finitura disponibile: grigio titanio sfumato-oro rosa/\*new finish available: fading titanium grey-rose gold



Una silhouette di vetro come  
archetipo figurato della lampada  
da appoggio

A glass silhouette that represents  
the archetype of table lamps



# AELLA

## tavolo/table

design toso & massari

*Aella* ha una forma costante nel tempo. Il suo disegno segna da principio l'immagine Leucos e trae il nome proprio dalla stessa origine greco antica dell'idioma del marchio di fabbrica. Il significato di tornado, bufera, vortice più propriamente, tante volte evocato dalla figura mitologica dell'amazzone che per prima si scagliò contro la prepotenza di Eracle, cristallizza la sua figura nell'immagine che saldamente persiste nei nostri occhi attraverso la qualità della sua luce. Il riflesso autentico, soffiato da una sapiente tradizione artigianale, ottenuto attraverso il modello del cono rovesciato, del vortice che rimbalza riempiendo lo spazio di luce, rende chiara e trasparente la coppa che accoglie i riverberi dal basso fino alla più pura diffusione. Appoggiata a una semplice e solida base questa silhouette di vetro rappresenta un archetipo figurato della lampada da appoggio.

*Aella's* shape has not changed over time. It's one of the first designs by Leucos, and its name, just like the trademark, comes from Ancient Greek. "Aella" was the name of the first Amazon warrior who lunged at Heracles, and is the Ancient Greek word for whirlwind, whose shape is echoed in the lines of the lamp and in the quality of light. Blown according to tradition by skilled artisans, the authentic glare is obtained through the model of the reversed cone, which bounces the light around like a vortex, while the transparent cup catches the reflections from below. Resting on a simple, robust base, this glass silhouette represents the archetype of table lamps.



AELLA T E27  
design 1968

AELLA T LED  
update 2017



# AELLA

sospensione/pendant

design toso & massari

Una rivoluzione recente segna il nuovo corso di *Aella*. Un rovesciamento concreto che reinterpreta il progetto -a partire dal 2016- immaginando un nuovo uso coerente e contemporaneo di un oggetto di culto consolidato. La sospensione proposta della coppa conosciuta, oltre ad esaltare i caratteri propri della forma evocativa, amplifica, nella leggerezza librata in aria, il senso profondo del re-design che a partire dalle qualità intrinseche di un'oggetto immagina innovative valorizzazioni adeguate alle sensibilità più recenti. Il carattere della lampada appoggiata rivive in questo modo della sospensione nello spazio così come nell'ideale interruzione del tempo. Luci LED di elevata qualità fanno rinascere con questo artificio una luce vivida che conosciamo da tempo orientandola questa volta verso terra.

A recent revolution set a new course for the *Aella* lamp. Thinking of a new consistent and contemporary use for a cult object, in 2016 the original design was reinterpreted and literally turned upside down. The well-known cup is now also a suspension lamp, which maintains the characteristic features of the original evocative shape. Hovering in the air, the new concept really shows what redesign means: taking the intrinsic properties of an object and imagining new ways to enhance them while capturing more recent trends. The suspension in space revives the personality of the table lamp, and the high-quality LEDs cast the same vivid light, this time directed downwards.

AELLA S LED  
evolution 2016



## Aella mini P-PL LED



IP44 - apparecchio protetto contro corpi solidi e spruzzi d'acqua  
IP44 - Unit protected against solid bodies and spray water

Sospesa, a parete o a soffitto, proposta con differenti finiture del vetro e sembianze del diffusore, cromie e sfumature, *Aella mini* a sospensione interpreta la varietà, la possibilità di scegliere all'interno di una larga gamma di personalizzazioni più vicine alle sensibilità individuali dell'epoca corrente. Sorretta allo stesso cavo che le fornisce energia, appesa a rosone, infissa in orizzontale, nella sua serie più piccola amplia la genealogia di un progetto capace di ridefinirsi a partire da costanti fisse fino a trasfigurare in nuovi e coerenti progetti una tradizione di disegno e qualità di preziosa lavorazione del vetro all'altezza di interpretare con efficacia l'attuale società.

Suspended, wall or ceiling mounted, available with various glass finishes, colours and shades and with a diffuser appearance, the *Aella mini* chandelier interprets diversity and the possibility of choosing from a wide range of customisations that are closer to individual perceptions of the current era. With its mini series, held in place by the same cable that provides power, hanging from a ceiling rose, and attached horizontally, Aella extends the genealogy of a project that can redefine itself, starting with defined constants and continuing on to transforming a tradition of design and quality in exquisite glass processing into new, coherent projects capable of consistently interpreting our society.

*new 2017*

# AELLA mini

sospensione pendant  
parete/wall

design toso & massari



## Aella mini S LED



*new 2017*

# AELLA mini tavolo/table

design toso & massari

Ancora oggi la personalità presente all'interno di tanti classici del design più riconosciuto trova la necessità di continuare una ricerca spesso ancora in atto. Aella mini ridiscute a partire dalla sua solida immagine proprio le capacità artigianali della bottega vetraria, proprio quel disegno soffiato della forma del calice che da sempre ne caratterizza la qualità affermata. Senza tradire il marchio, il carattere, la figura a vortice che l'ha costruita e resa famosa, questa nuova serie mini, elabora con differenti proporzioni la coppa di vetro, le sue finiture, le sue misure e i rapporti armonici in un manierismo contemporaneo che considera innovazione tanto la ricerca sulle fonti luminose quanto le forme che permettono di esprimerne il massimo della qualità.

To this day, the personality injected into many of the most recognised design constants still requires continued, ongoing research. Aella mini reconsiders items from its own well-established image, the craftsmanship of the glass-making workshop, the signature blown design of the glass shape that has always characterised its recognised quality. Without betraying the brand, the vortex shape that built it and made it famous, this new mini-series elaborates on the glass cup with different proportions, finishes, measurements and harmonious ratios in a contemporary manner that considers innovation to be both research into sources of light and shapes that allow the highest of quality to be conveyed.





Una tradizione di disegno e qualità, di preziosa lavorazione del vetro all'altezza di interpretare con efficacia l'attuale società

A tradition of design and quality in exquisite glass processing into new, coherent projects capable of consistently interpreting our society





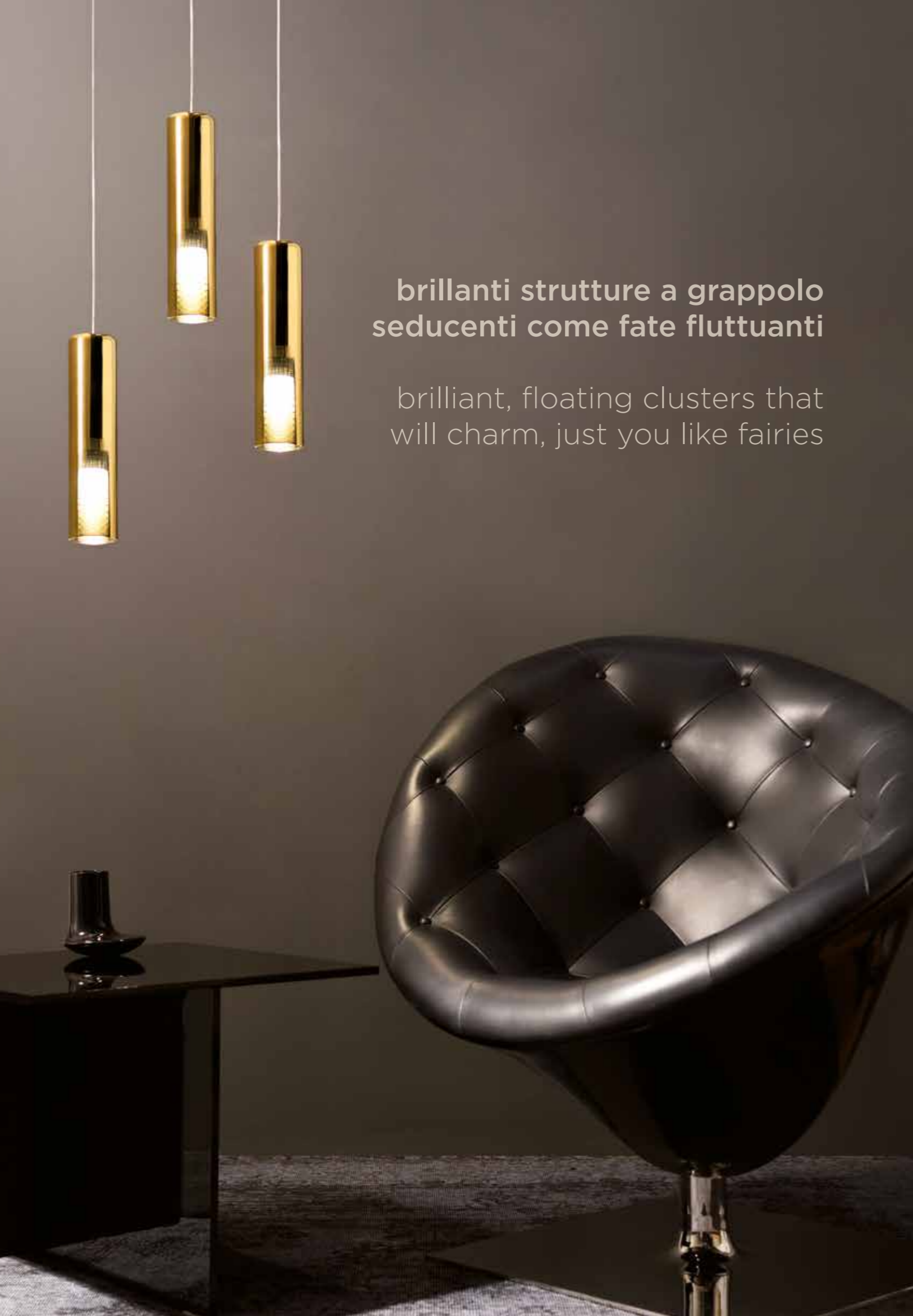

brillanti strutture a grappolo  
seducenti come fate fluttuanti

brilliant, floating clusters that  
will charm, just you like fairies

# FAIRY

design r.toso, n.massari  
& associates with g.toso

*Fairy* è il simbolo della trasparenza. Il disegno elementare della sua costruzione diventa in modo esplicito il principio costitutivo di questo sistema d'illuminazione che si mostra sincero in tutta la sua nudità. Diffusore e contenitore si confondono nella nitidezza del materiale che estremizza le caratteristiche del vetro borosilicato altamente termoresistente fino a evocare l'immagine della lampadina. Ma proprio l'estrema semplicità della figura di questo insieme lucente apre al contrario una varietà e versatilità interpretativa nella composizione delle misurate sagome e ripetizioni. Appese a rosone di uno, tre o cinque fili, concentriche o asimmetriche, variate dai differenti profili della sfera, del cilindro o del geoide, questi insiemi combinati permettono una personalizzazione e una varietà che allontana ogni monotonia in queste brillanti strutture a grappolo seducenti come fate fluttuanti.

*Fairy is the symbol of transparency. The streamlined design is the distinctive feature of this lighting system, which is as sincere as it is bare. The lampshade and the diffuser merge into a unique shape - evoking the image of a light bulb - made of incredibly clear and highly heat-resistant borosilicate glass. But it is thanks to its simplicity that this bright ensemble opens the way to a variety of interpretations and compositions: spheres, cylinders or geodes, hanging from one, three- or five-way ceiling rose, concentric or asymmetric. Unleash your imagination and combine these elements to create brilliant, floating clusters that will charm, just you like fairies. Now also available in four new metallic finishes chrome, gold, rose gold and ruthenium.*



**FAIRY LED S**  
**update 2017**



FAIRY LED table  
evolution 2017



## VOLTA evolution 2017

sistema di sospensione brevettato  
patented hanging system

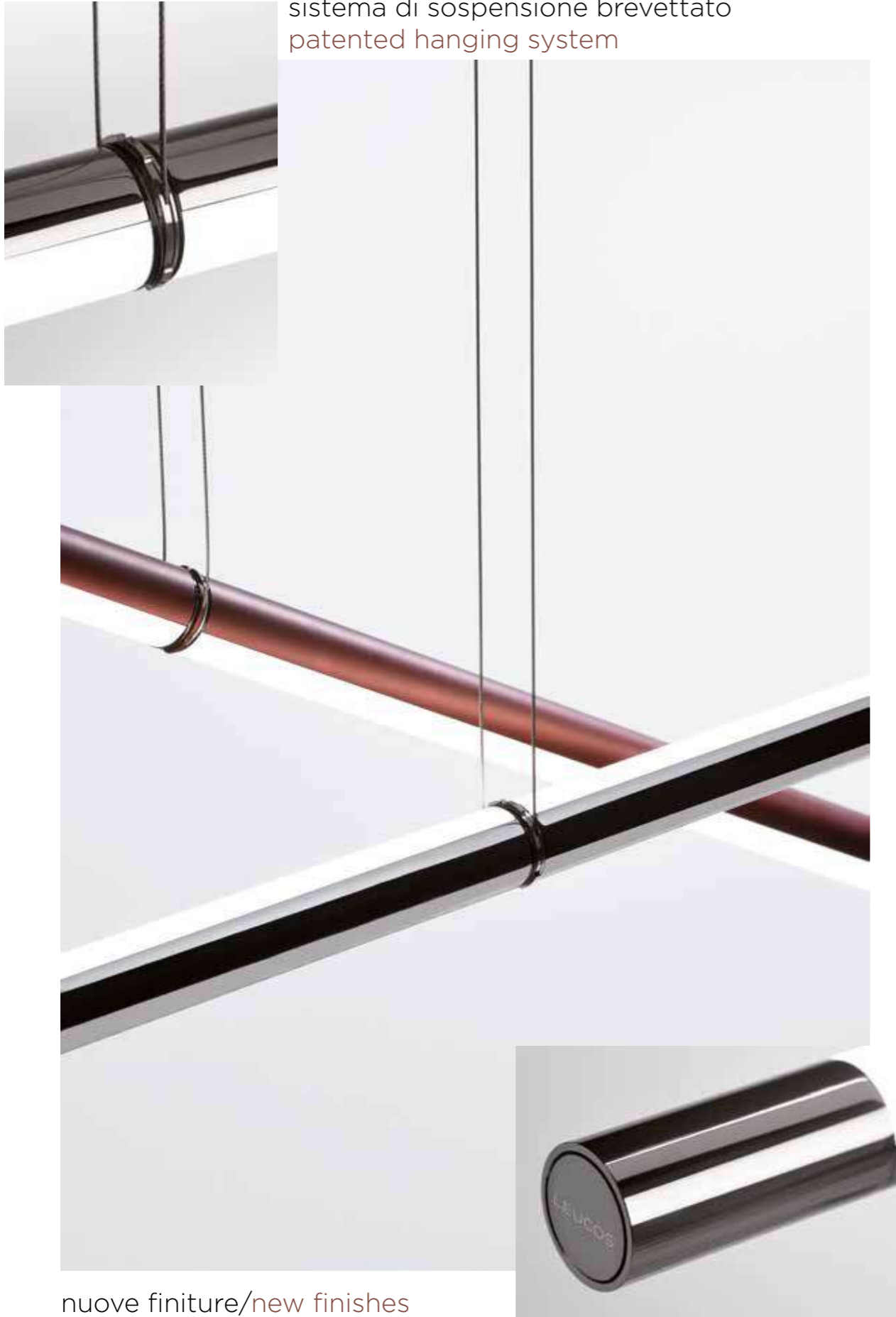

nuove finiture/new finishes

# VOLTA

design by  
from industrial design



*Volta* è una linea luminosa, una retta sospesa nell'aria che astrae la sua forma rappresentativa dalle semplici caratteristiche che ne contraddistinguono le qualità. È solo e unicamente un profilo sintetico, diretto, originale nel dimostrare le capacità tecniche di una lampada a sospensione duttile nell'uso, silenziosa nell'occupare lo spazio, flessibile nell'appropriarsi dei luoghi. Il progetto minimale che nasconde senza evidenze le ricercate qualità tecnologiche, i dispositivi d'uso, accensione e spegnimento, sospensioni e dimmeraggio, esprime l'identità del nome proprio nella qualità del possibile movimento che rivoluziona la rotazione sul suo asse a 360 gradi, permettendo così un'illuminazione a parete, a soffitto, o ancora su piani di lavoro attraverso il semplice rovesciamento della metà illuminante tra tutti i gradi possibili. Parallela al suolo o ancor meglio obliqua diventa un oggetto misterioso di luce intensa.

*Volta* is a luminous line that float in the air, and whose distinctive shape abstracts from its simple features. A suspension lamp that is also synthetic profile, and that shows its technical possibilities in a straightforward and original way. Flexible in its use, it's a silent presence that fills the space with discretion. The advanced technological features, such as the controls, the on/off switch, the dimmer and the suspensions are enclosed in a minimal design. The diffuser can rotate by 360 degrees and allows the warm white light to radiate upwards, downwards or sideways, so that you can easily change the atmosphere in the room with a single gesture. Keep it parallel to the floor or a little inclined: the effect will be that of a mysterious object casting an intense light.



**silenziosa nell'occupare  
lo spazio, flessibile  
nell'appropriarsi dei luoghi**

flexible in its use, it's a silent  
presence that fills the space  
with discretion





evolution 2017  
LEVA nuove essenze/  
new wood selection

# LEVA

design massimo iosa ghini, evolution 2017

*Leva* racconta l'ossimoro che è presente in ogni progetto. Dimostra con accuratezza e garbo il radicamento alla più felice tradizione, alla memoria costante di un passato autorevole, sommato alla tecnologia più innovativa già rivolta verso la luce di domani. In questa direzione di ricerca sapiente, materiali preziosi come il legno nelle differenti essenze, ingegni antichi - elementari come leve appunto -, misure studiate nei dettagli, riproducono, alla scala minore, i movimenti di una macchina, i meccanismi sofisticati, l'animazione studiata per un'innovativa illuminazione LED, efficace ed economica, sottile negli spessori e nei profili, elegante nella sagoma. Da tavolo, ma più propriamente attrice principale dei piani d'appoggio che occupa, ruba la scena a lampade di ben altra dimensione come un modello prezioso capace di rappresentare il felice incontro tra storia e modernità.

*Leva* reveals the oxymoron hidden in every project. It's an accurate and graceful example of how the tradition and the constant memory of a distinguished past can be successfully combined with the most innovative technology. This skillful research involves precious woods, ancient and simple mechanisms such as levers - hence the name - and rigorous measures to reproduce on a smaller scale the movements of a machine with its sophisticated mechanisms. The result of this happy meeting between history and modernity is an elegant lamp with thin and sleek profiles, and an innovative, efficient and cost-effective LED lighting. It will look great on your table and on any other surface in your home, and it might steal the show from other lamps, including bigger ones.





new switch  
touch dimmer  
(pat. pend.)



new LED circuit 800lm/CRI>90  
(available in dynamic white)



# IXI-O

design filippo caprioglio featuring leucos lab - update 2017

*IXI-O* è una lampada costruita dalla luce riflessa. Una luminosità preziosa disegnata attraverso la contrapposizione tra la sorgente luminosa, un piccolo anello ancorato a soffitto senza evidenza, e le brillanti aste in cristallo capaci di riverberare la tipicità di una luce che trae forza dall'urto con le bacchette sospese in equilibrio. Ricorda il gioco dello shanghai, un groviglio di linee preziose con decori metallizzati a specchio tracciati all'interno della sezione dei tubi inerti che rimbalzano fasci e scintille, bagliori e luccichii verso infinite direzioni.

L'immaginazione corre velocemente a prima vista composizioni più complesse che dal modulo singolo dispongono altri pezzi e altri ancora sommando in parallelo, al di sopra o al di sotto, nuovi garbugli illuminati fino a desiderare di riempire spazi di più grandi dimensioni, superfici complete, soffitti e pareti di ghiaccio luccicante

The *IXI-O* lamp is made of reflected light. a precious innovation consisting of a double LED light source, a ceiling rose that projects the light from above, and a series of small rings in the shape of an "O". Sparkling crystal tubes have been inserted in every ring and balance in an apparently random fashion, reflecting the light and adding extra intensity to it. This tangle of precious lines reminds of the game of pick-up sticks or a juggler's sticks tumbling in the air, and the reflective gold, silver and ruthenium decorations inside the tubes bounce around a beams and glares, in a kaleidoscope of lights and colours. As soon as you see it, your imagination will start running loose: the modules can be added and combined into complex structures, and this possibility will make you want to fill large spaces, surfaces, ceilings and walls with an illuminated jungle of sparkling ice.



# O-LOOP

sospensione/pendant

design leucos lab, 2017



"O-LOOP" anello metallico luminoso (LED dimmerabile), applicato al cilindro "IXI", è il più recente progetto sviluppato da leucos lab

"O-LOOP" lighting metal ring (with dimmable LED) applied to the tubular glass element of "IXI": brand new project developed by leucos lab

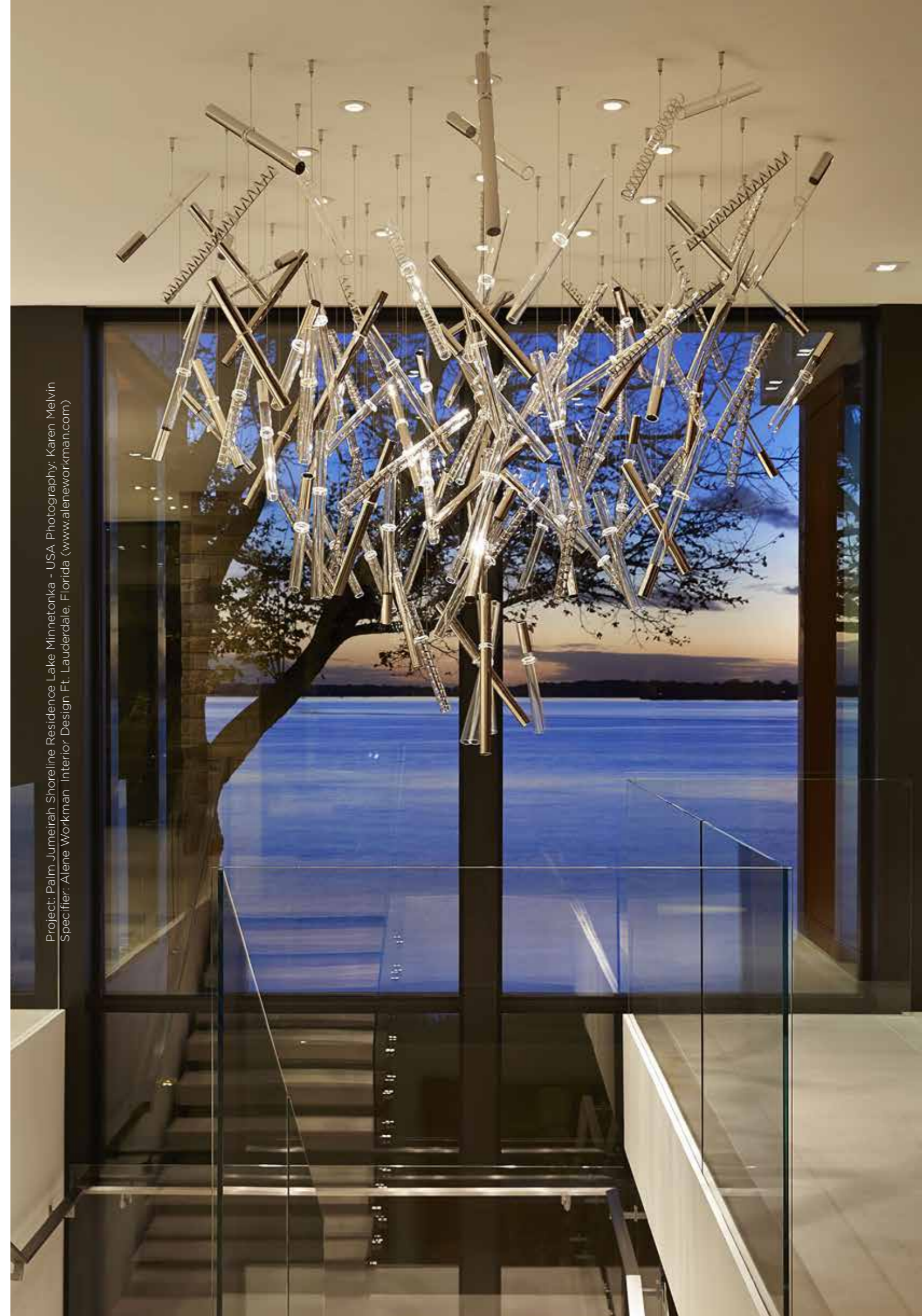

Project: Palm Jumeirah Shoreline Residence Lake Minnetonka - USA Photography: Karen Melvin  
Specifier: Alene Workman Interior Design Ft. Lauderdale, Florida (www.aleneworkman.com)



# JJ

## tavolo/table

design leucos lab, evolution 2017



JJ rappresenta dalla sua nascita il prototipo della lampada da lettura. La doppia iniziale delle generalità del designer norvegese che l'ha disegnata identificano da sempre un oggetto che è diventato culto della modernità. Meccanica, mobile, leggera, tipica nel sistema di accensione, modulare nelle proporzioni, significativa nell'espressività formale che evidenzia aste e molle, distanziatori e perni, JJ riassume con le sue forme gli stilemi della modernità sottolineando il traguardo e l'emancipazione di un'epoca che scopre le qualità della produzione in serie.

Pluricopiata, ma mai superata, ha sfruttato negli ultimi anni la forza della sua immagine per derivare nuovi modelli, differenti solo per la scala di misura che dalla mini alla great sembrano ammiccare al lavoro del grande artista Claes Oldenbourg, trasfigurando spazi, spiazzando, entusiasmando. Nuove finiture, colorazioni personalizzate completano un prodotto che a buon diritto può comparire in ogni ambiente privato, pubblico, collettivo e perfino all'aperto nella sua dimensione massima.

JJ is considered the prototype of the desk lamp. The two letters that make up its name are the initials of the Norwegian designer who created it, and since then they have indicated an object which belongs to the cult of modernity. Flexible, modular and lightweight, this lamp is

characterised by distinctive joints, pintles and springs.

Its design summarises the stylistic features of modernity and has become the symbol of the emancipation which followed the rise of mass production.

Much imitated but never bettered, its strong image has inspired a series of new models in different sizes - ranging from mini to great - which transform the space and surprise the observer, just like Claes Oldenbourg's works of art. An iconic product that fits environments of any kind, including private, public, collective and outdoors locations (new colours and finishes available for full customisation).





JJ evolution 2017





# The Great JJ

design leucos lab, 2005

Un prodotto iconico che a buon diritto può comparire in ogni ambiente privato, pubblico, collettivo e perfino all'aperto nella sua dimensione massima

An iconic product that fits environments of any kind, including private, public, collective and outdoors locations

ora realizzabile in qualunque colore  
a campione anche per un singolo pezzo  
available in any sample colour  
even for one piece







**SCHEDE TECNICHE**  
DATA SHEETS

# TRIGONA

design danilo de rossi, 2015

## SCHEDA TECNICA/DATA SHEET

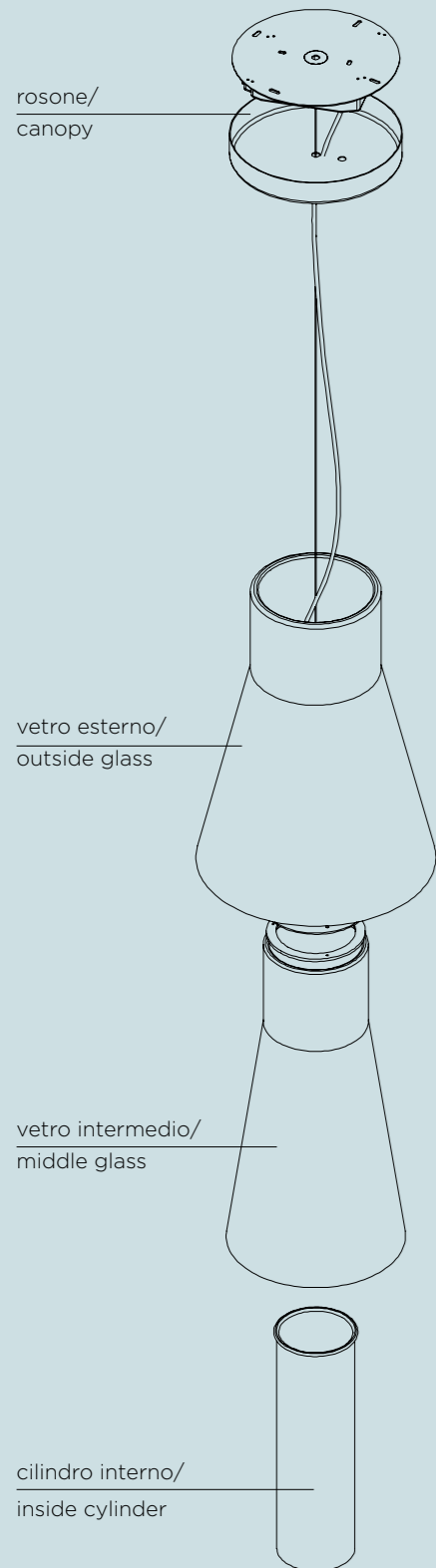

### tipologia/application

sospensione/pendant

### diffusore/diffuser

tre diffusori sovrapposti in vetro borosilicato soffiato, disponibile in diverse combinazioni colore/three nested diffuser, in borosilicate blown glass, available in different colour combinations

### struttura/structure

metallo cromato/chromed metal

### sorgente luminosa/light source

luce diretta/direct light: LED 15W 2700K 1650lm

+ 1 circuito circolare luce diretta (anello)/+ 1 circular circuit direct light (ring): LED 9 W 2700K 810lm

+1 circuito circolare luce indiretta/ + 1 circular circuit indirect light: LED 6W 2700K 610lm

totale emissione/total emission: 3070lm

### classe di isolamento/appliance class

⊕ classe I/class I

### certificazioni/certifications

CE IP 20

### note/notes

dimmer: 0-10V; 1-10V / push dim 2-100%/DALI

doppia accensione/double switch: 15W/9W + 6W

doppia dimmerazione/double dimming: 15W/9W+6W

### dimensioni/dimensions

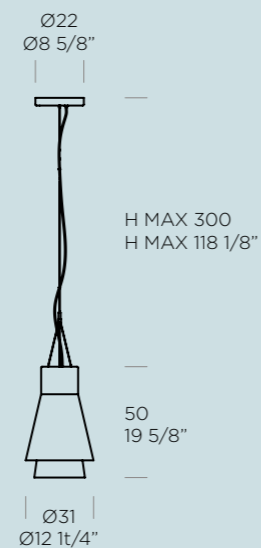

### finiture/finishes

### vetro/glass

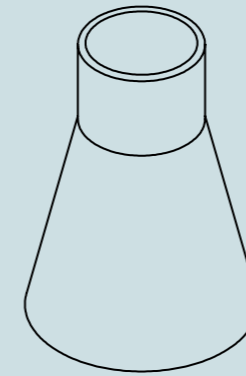

vetro esterno/  
outside glass

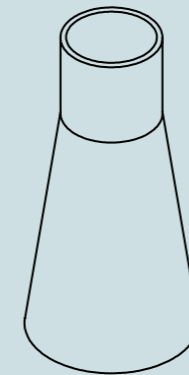

vetro intermedio/  
intermediate glass



cilindro interno/  
inside cylinder

nero sfumato/  
fading black

bianco sfumato/  
fading white

**new finish**  
grigio titanio sfumato/  
fading titanium grey

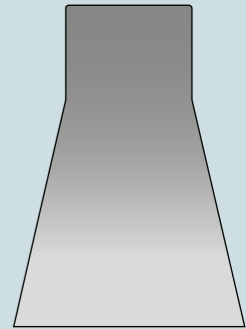
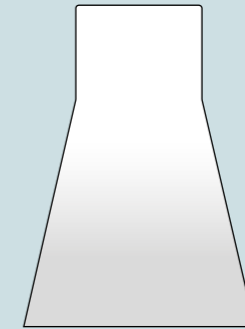
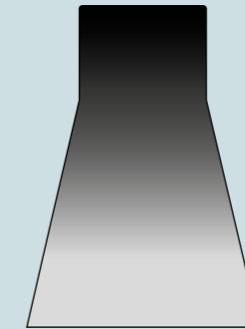

oro/  
gold

grigio titanio/  
titanium grey

bordeaux/  
bordeaux

**new finish**  
oro rosa/  
rose gold



vetro trasparente/  
transparent glass

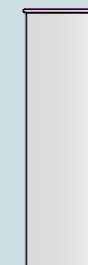



# AELLA T LED

design toso & massari, update 2017

## SCHEDA TECNICA/DATA SHEET

### dimensioni/dimensions

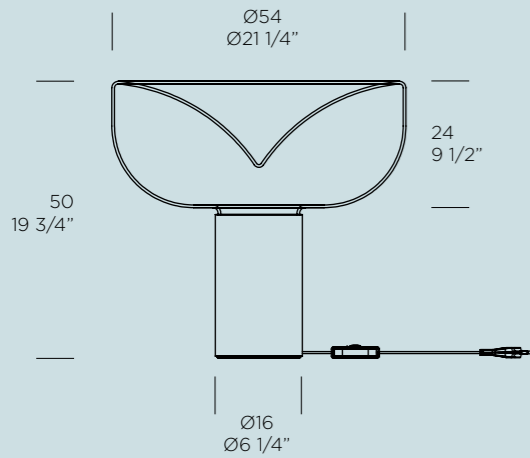

### tipologia/application

tavolo/table

### diffusore/diffuser

vetro soffiato trasparente/clear blown glass

### struttura/structure

base in acciaio lucido nelle finiture cromo e canna di fucile/steel base available in polished chrome and gunmetal black finishes

### sorgente luminosa/light source

LED 17W 3000K 2250lm

### classe di isolamento/appliance class

classe II/class II

### certificazioni/certifications

CE IP 40

### note/notes

dimmerabile/dimmable

### finiture/finishes

#### vetro/glass

trasparente/  
clear

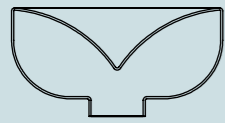

diffusore/diffuser

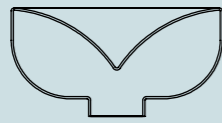

#### metallo/metal

cromo/  
chrome

canna di fucile/  
gunmetal black

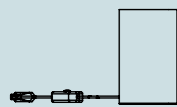

base tavolo/table base

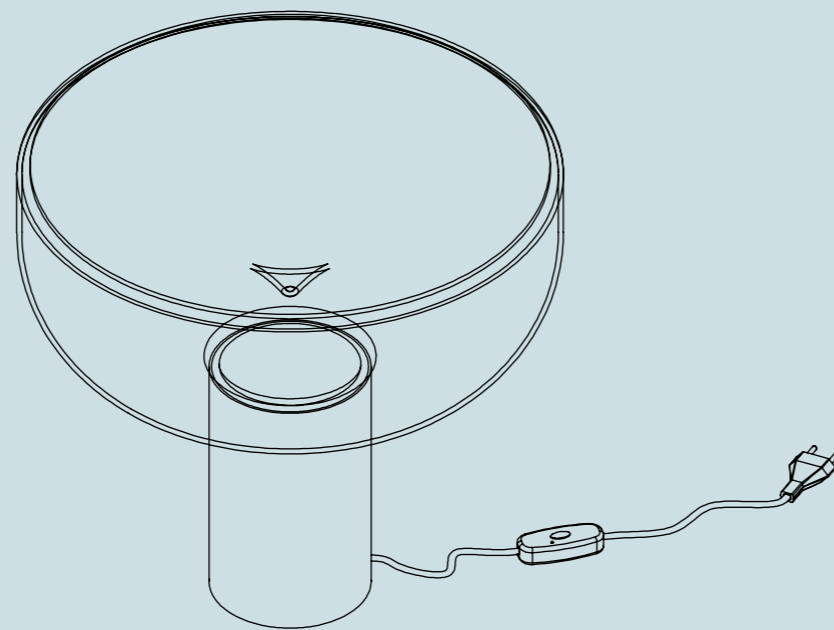

# AELLA S

design toso & massari, 2016

## SCHEDA TECNICA/DATA SHEET

### dimensioni/dimensions

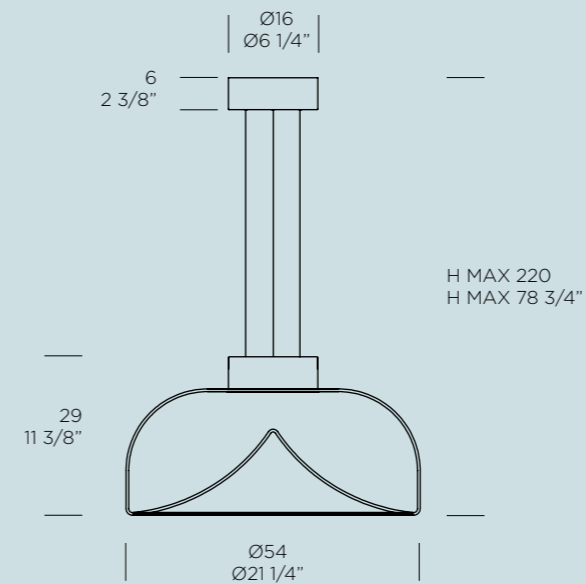

### tipologia/application

sospensione/pendant

### diffusore/diffuser

vetro soffiato trasparente/clear blown glass

### struttura/structure

struttura in acciaio lucido nelle finiture cromo e canna di fucile/steel structure available in polished chrome and gunmetal black finishes

### sorgente luminosa/light source

LED 26W 3000K 3200lm

### classe di isolamento/appliance class

classe II/class II

### certificazioni/certifications

CE IP 40

### note/notes

dimmerabile/dimmable: 1-10V/push-dim/dali

### finiture/finishes

#### vetro/glass

trasparente/  
clear

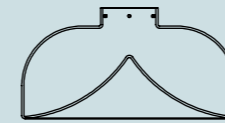

diffusore/diffuser

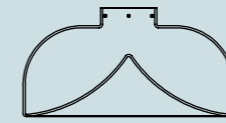

#### metallo/metal

cromo/  
chrome

canna di fucile/  
gunmetal black



rosone/canopy

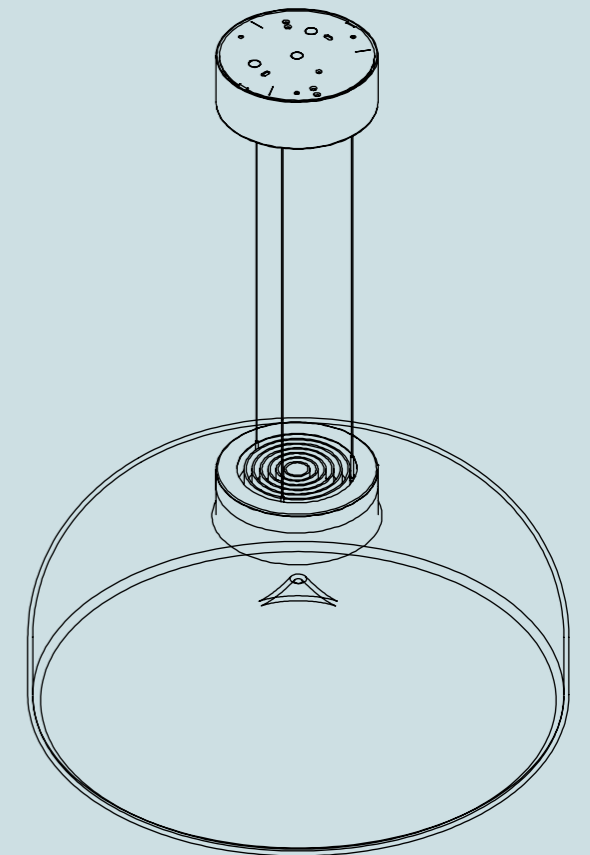

# AELLA mini P-PL

design toso & massari, 2017

## SCHEDA TECNICA/DATA SHEET

### versioni/variations

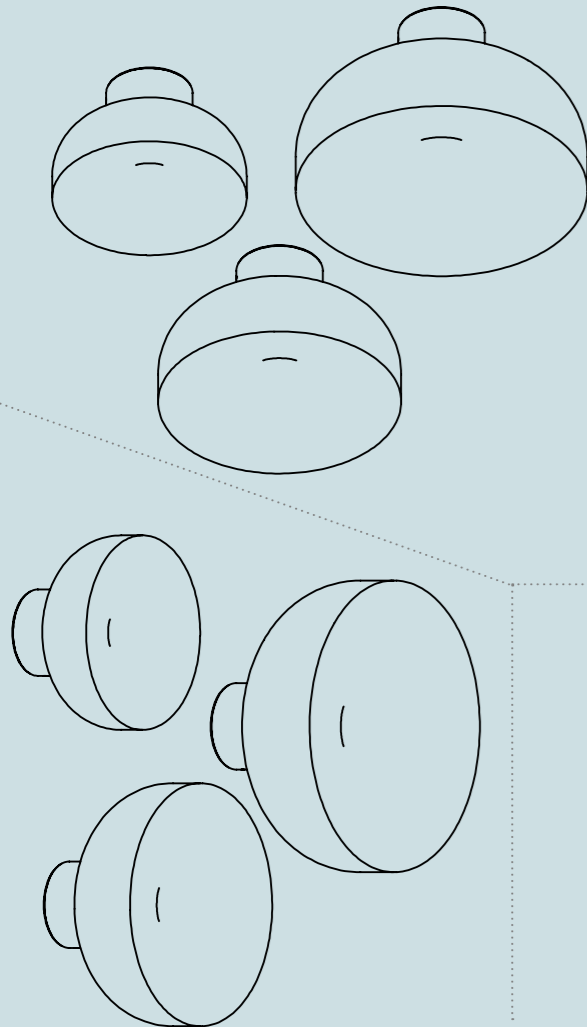

### tipologia/application

parete-plafone/wall-ceiling

### diffusore/diffuser

vetro soffiato disponibile in differenti forme e finiture/  
blown glass available in different shapes and colours

### struttura/structure

struttura disponibile in metallo o legno/  
structure available in metal or wood

### sorgente luminosa/light source

LED 8W 3000K 650lm CRI>90

### classe di isolamento/appliance class

classe II/class II

### certificazioni/certifications

CE IP 44

### note/notes

dimmerabile a taglio di fase/phase-cut dimmer

### AELLA mini 20 P-PL

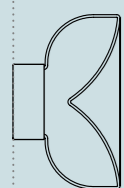
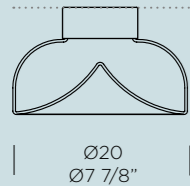

### AELLA mini 25 P-PL

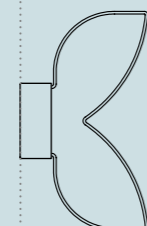
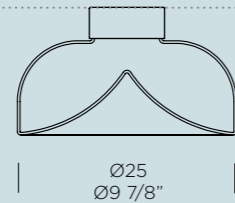

### AELLA mini 30 P-PL

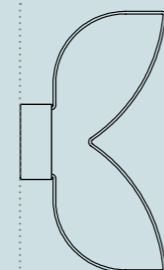
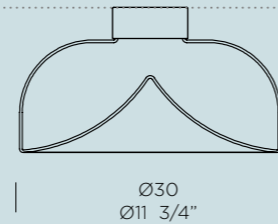

# AELLA mini S

design toso & massari, 2017

## SCHEDA TECNICA/DATA SHEET

### versioni/variations

### 3-4 sospensioni/3-4 suspensions

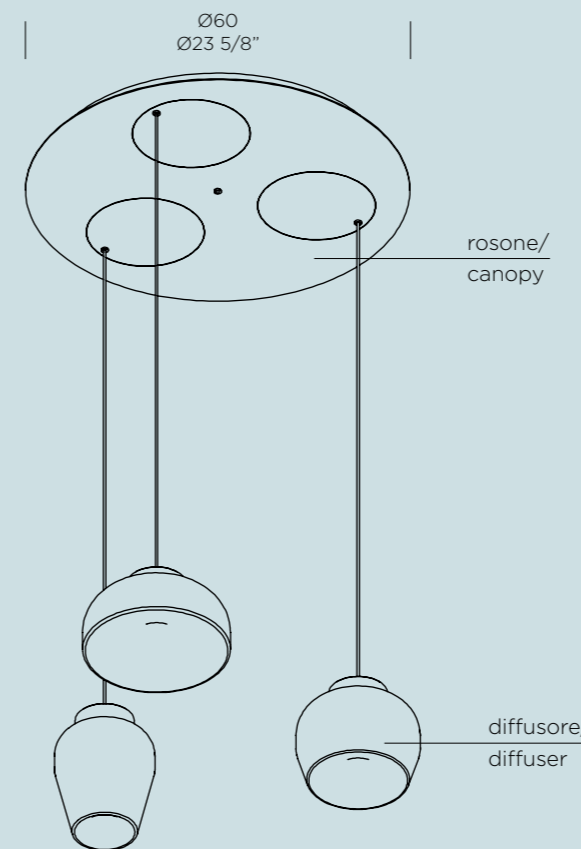

### tipologia/application

sospensione/pendant

### diffusore/diffuser

vetro soffiato disponibile in differenti forme e finiture/  
blown glass available in different shapes and colours

### struttura/structure

struttura a sospensione singola disponibile in metallo o  
legno; sistema a 3-4 sospensioni, disponibile in metallo  
/single structure available in metal or wood; 3-4 cluster  
system available in metal

### sorgente luminosa/light source

LED 5W 3000K 676lm CRI>90

### classe di isolamento/appliance class

classe II/class II

### certificazioni/certifications

CE IP 40

### note/notes

dimmerabile a taglio di fase/phase-cut dimmer

### sospensione singola/single suspension

### AELLA mini 20 S

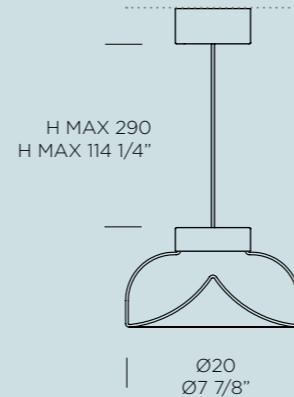

### AELLA mini 25 S

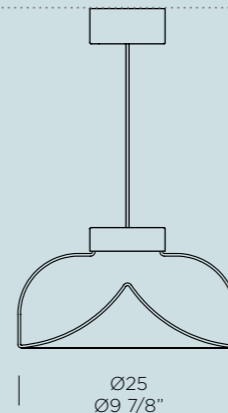

### AELLA mini 30 S

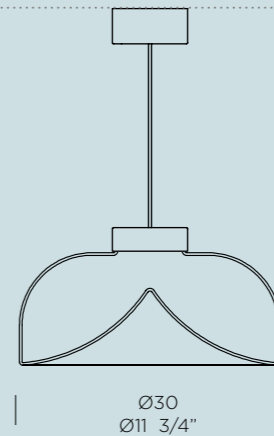

### AELLA BOLD S

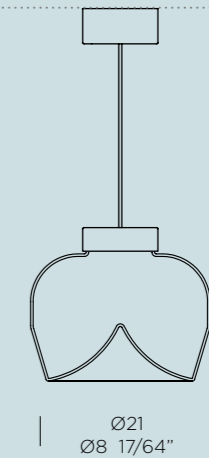

### AELLA THIN S

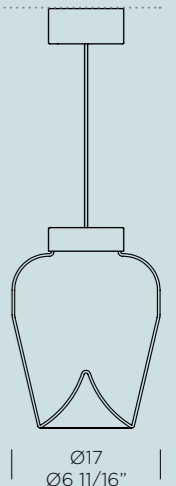



# AELLA mini T

design toso & massari, 2017

## SCHEDA TECNICA/DATA SHEET

### versioni/variations

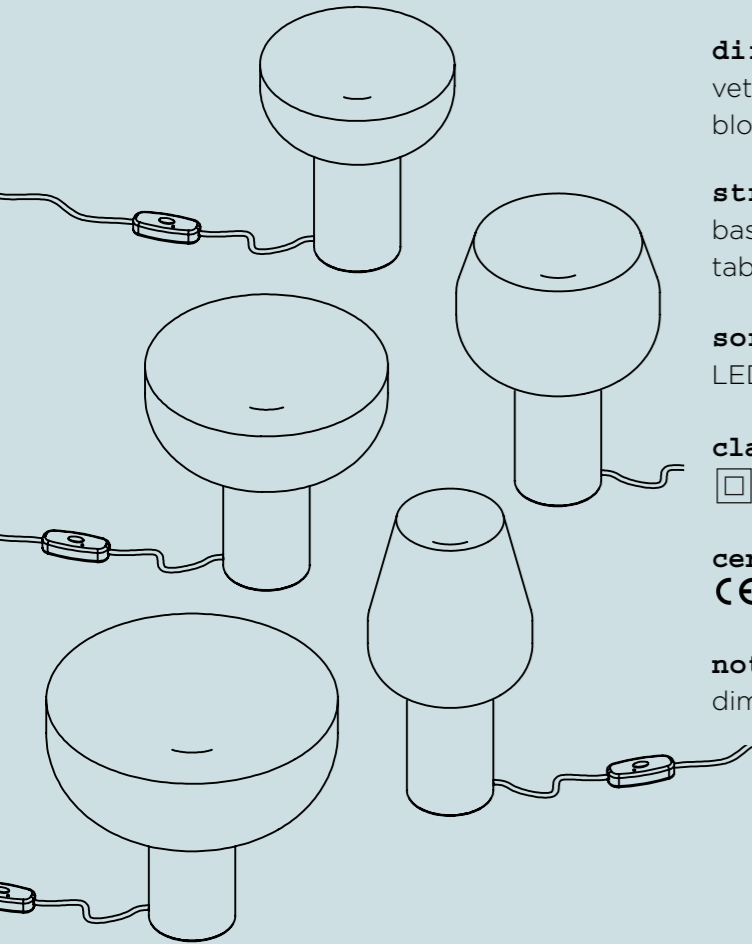

### tipologia/application

tavolo/table

### diffusore/diffuser

vetro soffiato disponibile in differenti forme e finiture/  
blown glass available in different shapes and colours

### struttura/structure

base da tavolo disponibile in metallo, legno o marmo/  
table base available in metal, wood or marble

### sorgente luminosa/light source

LED 8W 3000K 650lm CRI>90

### classe di isolamento/appliance class

classe II/class II

### certificazioni/certifications

CE IP 40

### note/notes

dimmerabile/dimmable

**AELLA mini 20 T**

**AELLA mini 25 T**

**AELLA mini 30 T**

**AELLA BOLD T**

**AELLA THIN T**

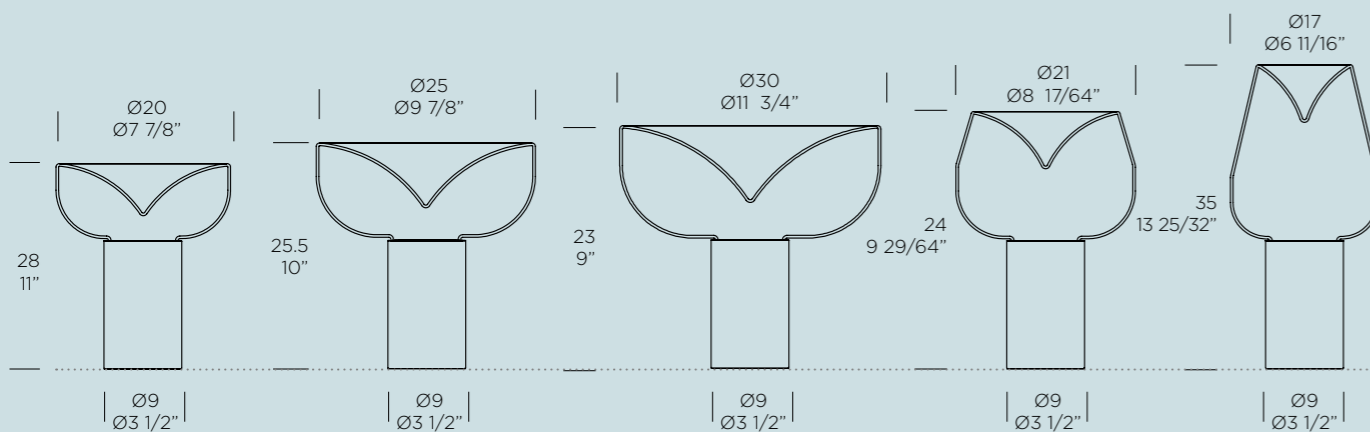

### finiture/finishes

#### vetro/glass

	grigio sfumato/ fading grey	ametista sfumato/ fading amethyst	verde sfumato/ fading green	marrone sfumato/ fading brown	trasparente/ clear	bianco sfumato/ fading white	bianco sfumato pulegoso/ pulegoso fading white	vetro antico/ ancient glass
<b>AELLA mini 20</b>								
<b>AELLA mini 25</b>								
<b>AELLA mini 30</b>								
<b>AELLA BOLD</b>								
<b>AELLA THIN</b>								

#### metallo/metal

	cromo/ chrome	oro/ gold	oro rosa/ rose gold	canna di fucile/ gunmetal black	legno/wood	trako/ trako	marmo/marble	onice bianco/ white onyx	nero port laurent/ black port laurent
<b>tavolo/table</b>									

#### parete/wall

--	--	--	--	--	--	--	--	--	--

#### sospensione/pendant

--	--	--	--	--	--	--	--	--	--

#### sistema sospensione/ pendant system

--	--	--	--	--	--	--	--	--	--

# FAIRY LED S

design r.toso, n.massari & associates with g.toso

## SCHEDA TECNICA/DATA SHEET

### dimensioni/dimensions

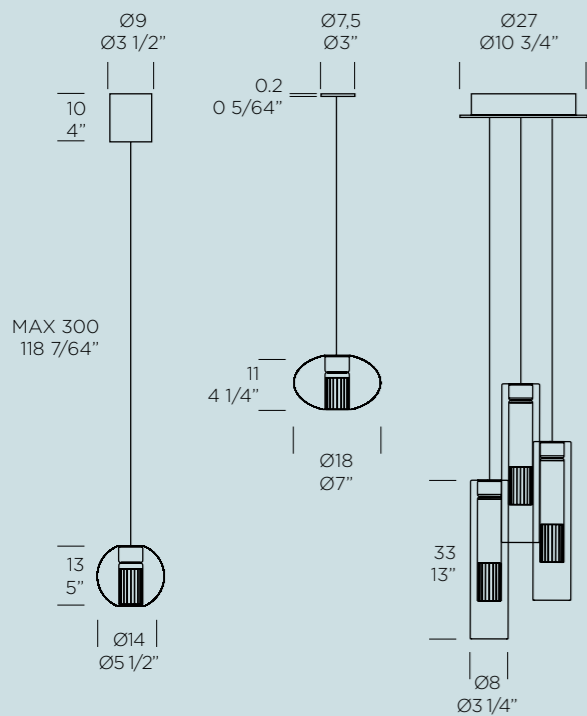

### tipologia/application

sospensione/pendant

### diffusore/diffuser

diffusori in vetro borosilicato con decoro in tubo rigato disponibile in differenti forme e finiture/diffusers in borosilicate glass with a ribbed tube accent available in different shapes and finishes

### struttura/structure

struttura in metallo cromato/chromed metal structure

### accessori/accessories

kit 3 per decentramento sospensione-cromo/ off center kit 3 for suspension-chrome

### sorgente luminosa/light source

LED 3,2W 3000K 380lm

### classe di isolamento/appliance class

⊕ classe I/class I

### certificazioni/certifications

CE IP 20

### note/notes

dimmerabile a taglio di fase/phase-cut dimmer

### versioni/variations

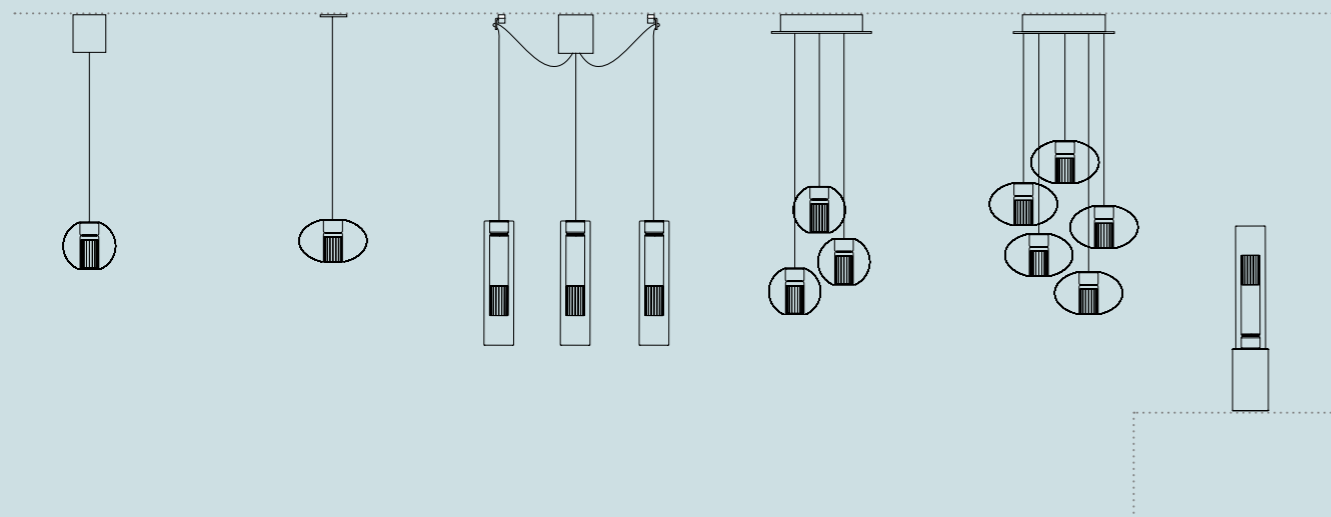

# FAIRY LED T

design r.toso, n.massari & associates with g.toso

## SCHEDA TECNICA/DATA SHEET

### dimensioni/dimensions

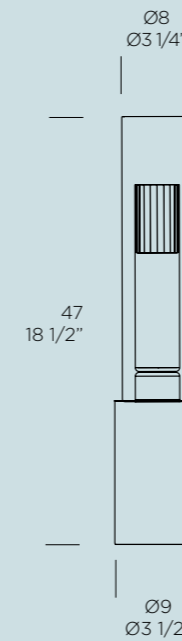

### tipologia/application

tavolo/table

### diffusore/diffuser

cilindri in vetro borosilicato con decoro in tubo rigato disponibile in differenti finiture/cylinders in borosilicate glass with a ribbed tube accent available in different finishes

### struttura/structure

struttura disponibile in quattro differenti finiture/ structure availables in four different finishes

### sorgente luminosa/light source

LED 8W 3000K 650lm CRI>90

### classe di isolamento/appliance class

⊕ classe II/class II

### certificazioni/certifications

CE IP 20

### note/notes

dimmerabile/dimmable

### finiture/finishes

vetro/glass	chromo sfumato/ fading chrome	oro sfumato/ fading gold	oro rosa sfumato/ fading rose gold	canna di fucile sfumato/ fading gunmetal black	trasparente/ clear	metallo/metal	chromo/ chrome
FAIRY S							
FAIRY G							
FAIRY C							



# VOLTA

design by from industrial design, 2016

## SCHEDA TECNICA/DATA SHEET

### dimensioni/dimensions

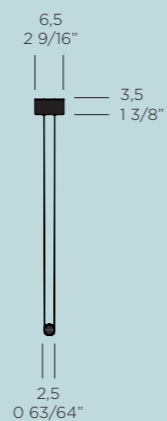
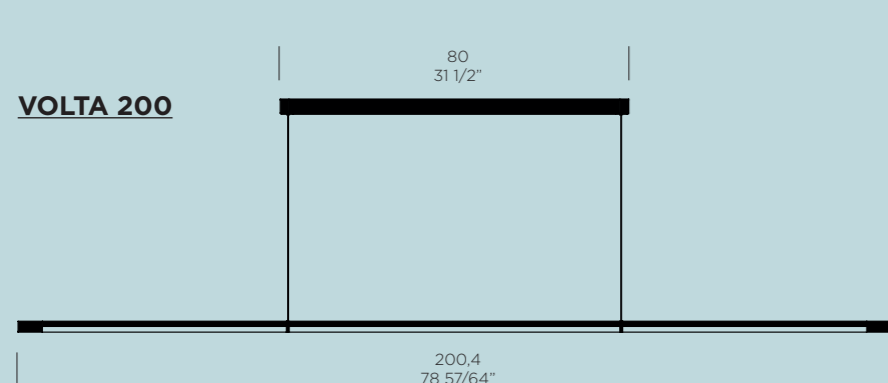
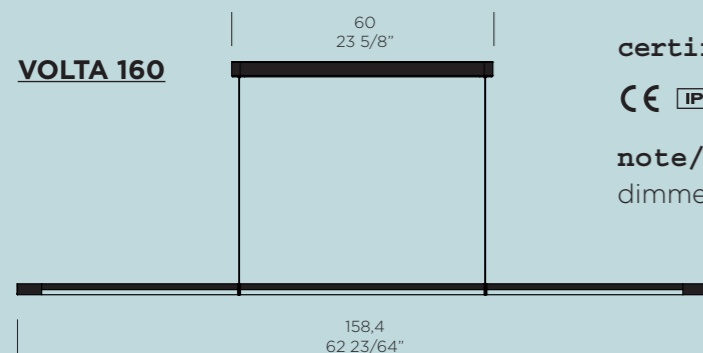
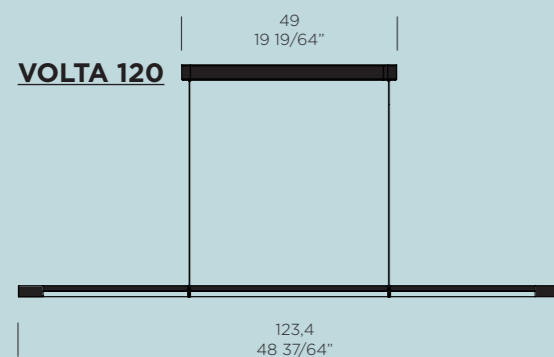

### tipologia/application

sospensione/pendant

### diffusore/diffuser

diffusore in polimetilmetacrilato (PMMA) satinato/  
diffuser in glazed polymethyl-methacrylate (PMMA)

### struttura/structure

struttura in alluminio nelle quattro finiture: bianco opaco, borgogna opaco, cromo, nero raggrinzante opaco/aluminium structure in the four finishes: matt white, matt burgundy, chrome, matt wrinkle black

### sorgente luminosa/light source

VOLTA 120 LED 23W 2700K 1950lm CRI>90  
VOLTA 160 LED 30W 2700K 2560lm CRI>90  
VOLTA 200 LED 39W 2700K 3290lm CRI>90

### classe di isolamento/appliance class

⊕ classe I/class I

### certificazioni/certifications

CE IP 40

### note/notes

dimmerabile touch/touch dimmer 5-100%

### finiture/finishes

#### metallo/metal



bianco opaco/matt white

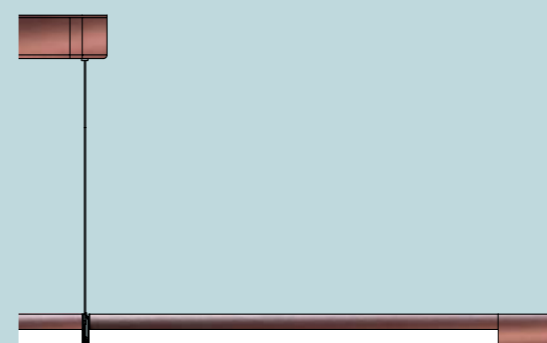

borgogna opaco/matt burgundy



cromo/chrome

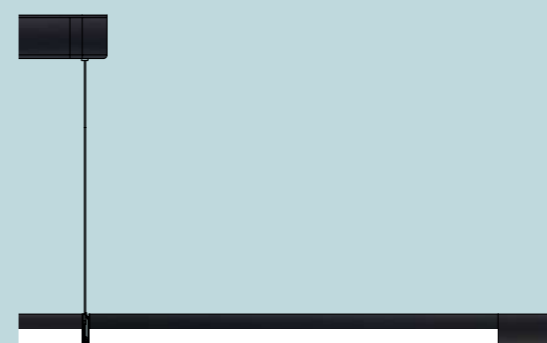

nero raggrinzante opaco/matt wrinkle black

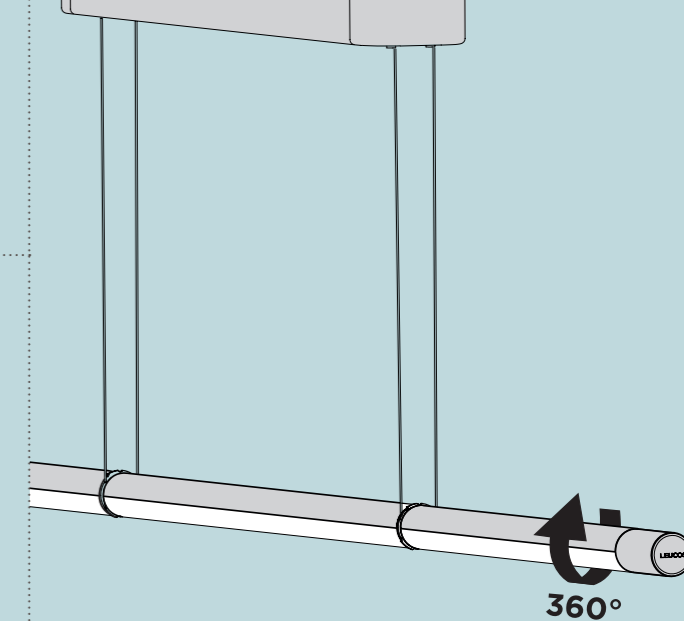

360°

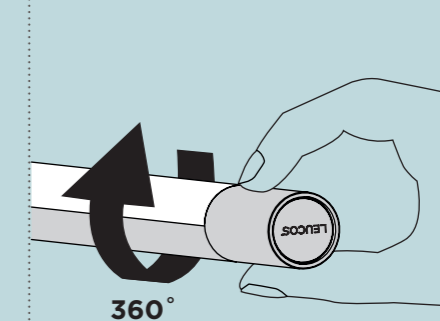

360°

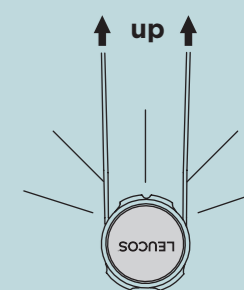

up

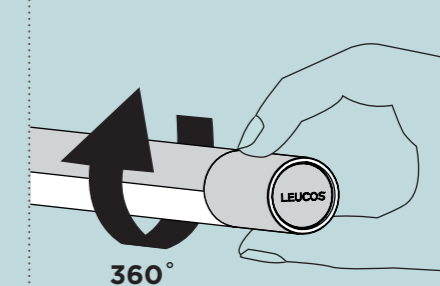

360°

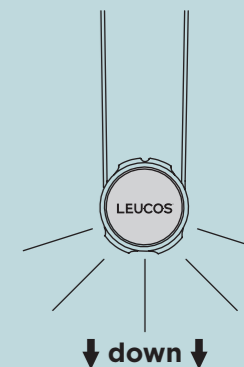

down

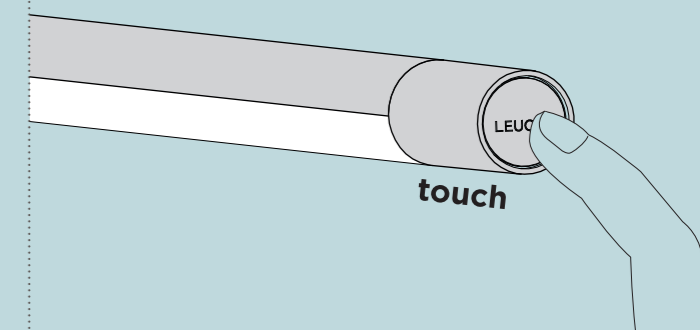

touch

# LEVA

design massimo iosa ghini, evolution 2017

## SCHEMA TECNICA/DATA SHEET

### dimensioni/dimensions

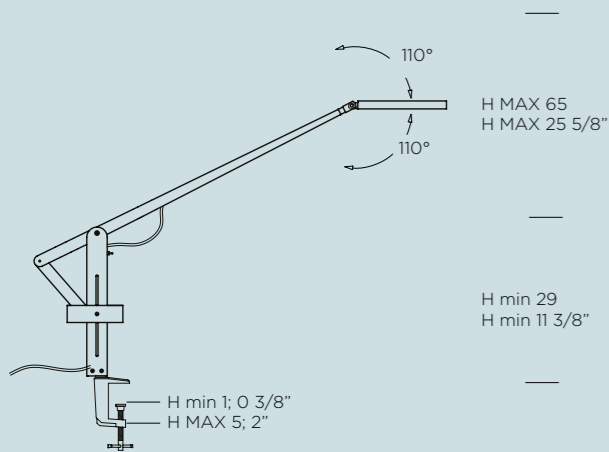

L MAX 78; 30 3/4"  
L min 57; 22 1/2"

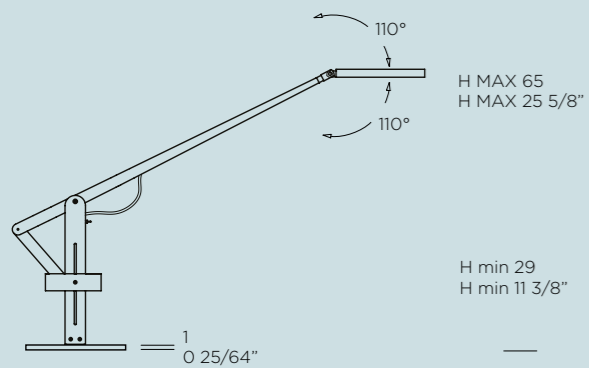
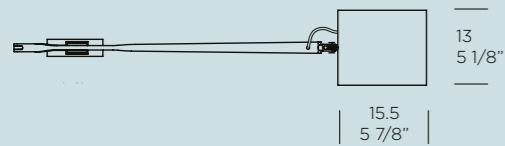

L MAX 78; 30 3/4"  
L min 57; 22 1/2"

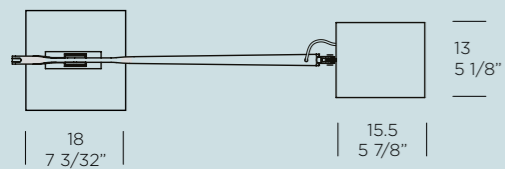

### tipologia/application

tavolo/table

### diffusore/diffuser

diffusore in polimetilmetacrilato (PMMA) bianco opale/  
diffuser in opal white polymethyl-methacrylate (PMMA)

### struttura/structure

palissandro; noce canaletto; mogano; faggio sbiancato/  
rosewood; wot; mahogany; bleached beech

### accessori/accessories

morsetto (di serie) o base quadrata in acciaio  
(opzionale)/clamp (standard) or square base steel  
(optional)

### sorgente luminosa/light source

LED 10,5W 3000K 800lm CRI>90

### classe di isolamento/appliance class

III classe III/class III

### certificazioni/certifications

CE IP 40

### note/notes

dimmerabile touch/touch dimmer  
switch dimmable pat. pend.

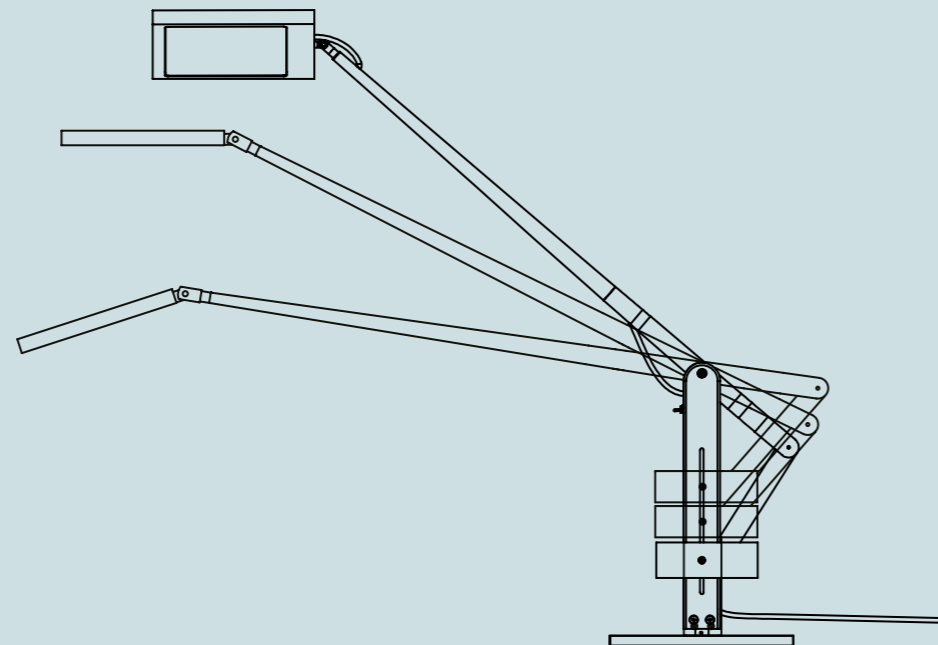

### finiture/finishes

#### legno/wood

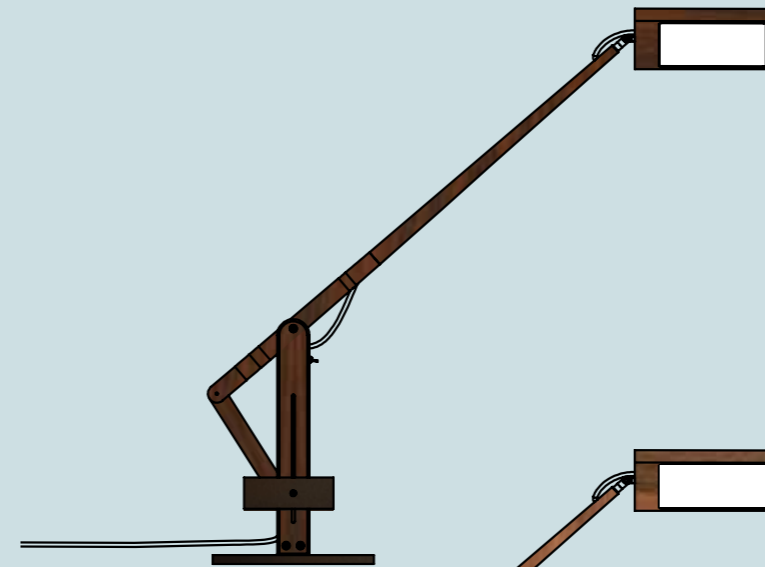

palissandro + base verniciata nera/  
rosewood + painted black base

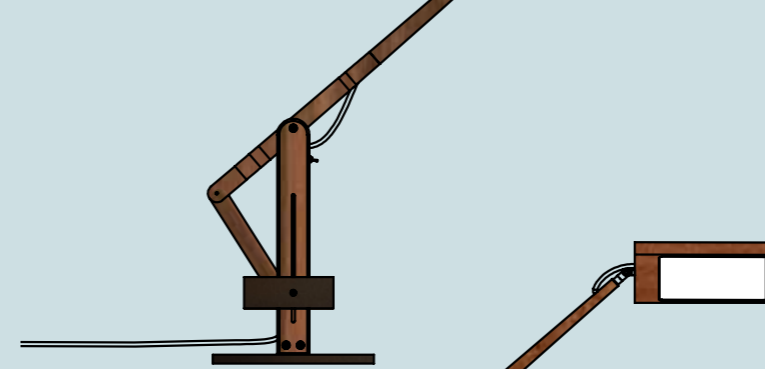

noce + base verniciata nera/  
wot + painted black base

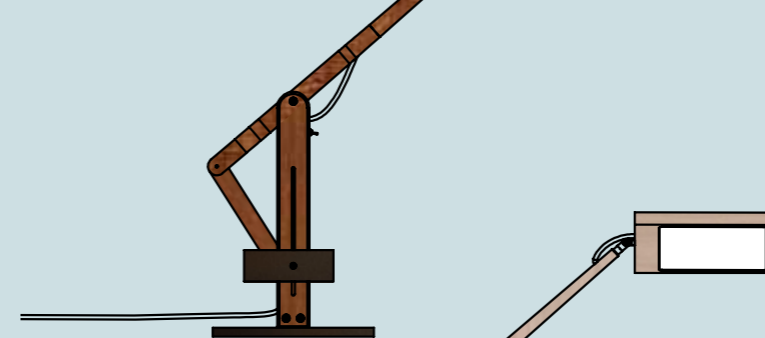

mogano + base verniciata nera/  
mahogany + painted black base

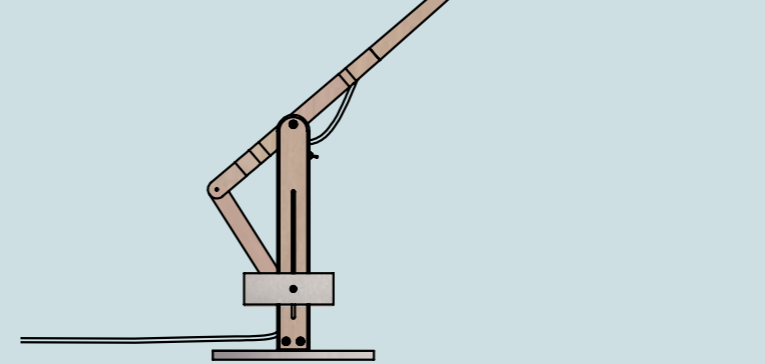

faggio sbiancato + base verniciata grigio alluminio/  
bleached beech + painted aluminium grey base

### accessori/accessories

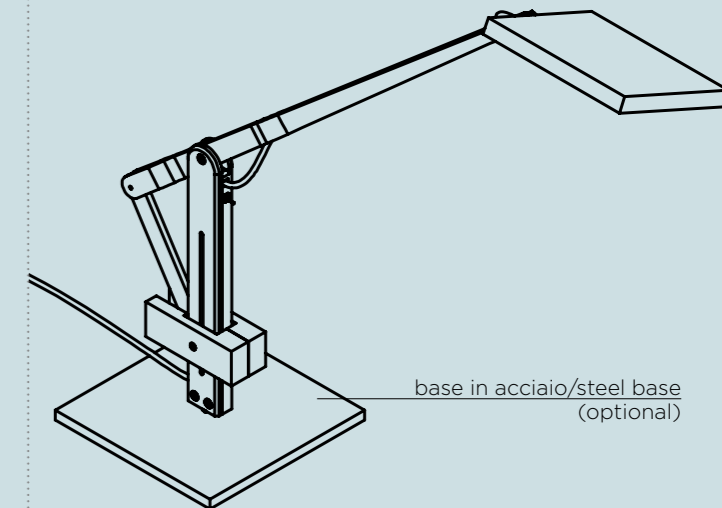
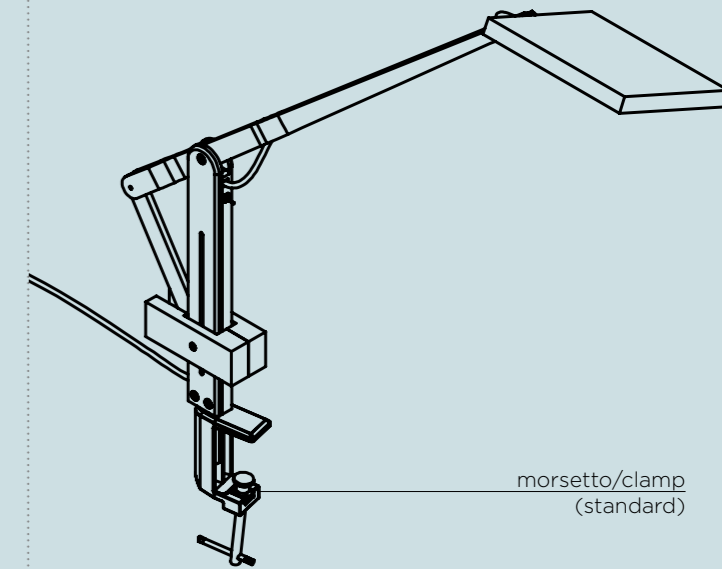



# IXI-O

design filippo caprioglio feat. leucos lab, 2017

## SCHEMA TECNICA/DATA SHEET

### dimensioni/dimensions

#### IXI 50

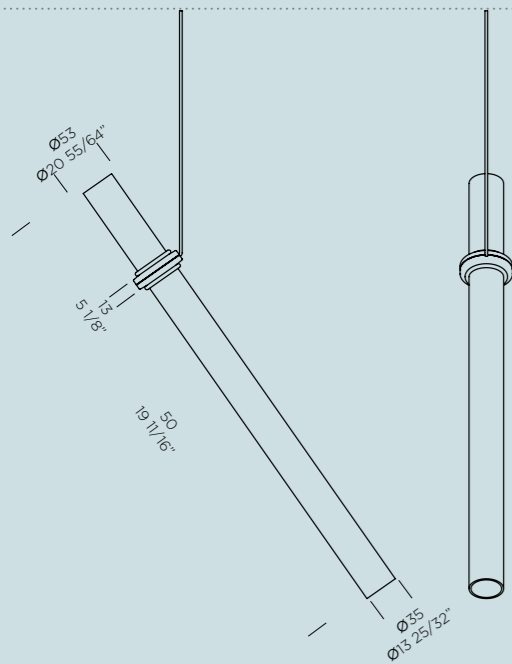

### tipologia/application

sospensione/pendant

### diffusore/diffuser

diffusori cilindrici in borosilicato con decoro metallizzato/borosilicate cylindrical diffusers with metallic decoration

### struttura/structure

anello in alluminio con illuminazione interna (LED)/aluminum ring with interior lighting (LED)

### sorgente luminosa/light source

LED 2,5W 3100K 210lm

### classe di isolamento/appliance class

III classe III/class III

### certificazioni/certifications

CE IP 20

### note/notes

dimmerabile con pulsante esterno (pulsante esterno non fornito)/1-10V/dimmable with external button (external button not supplied)/1-10V

#### IXI 35

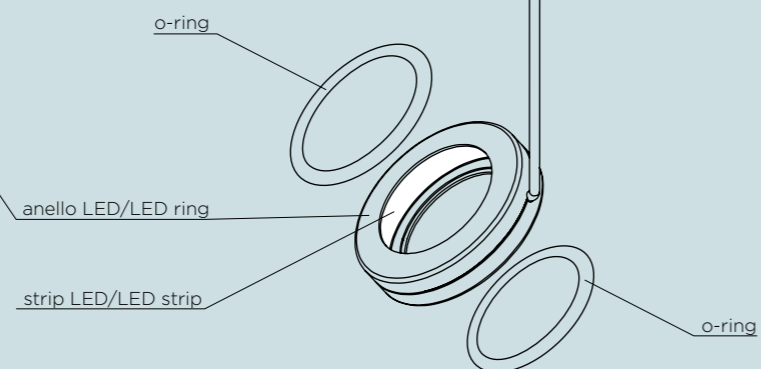
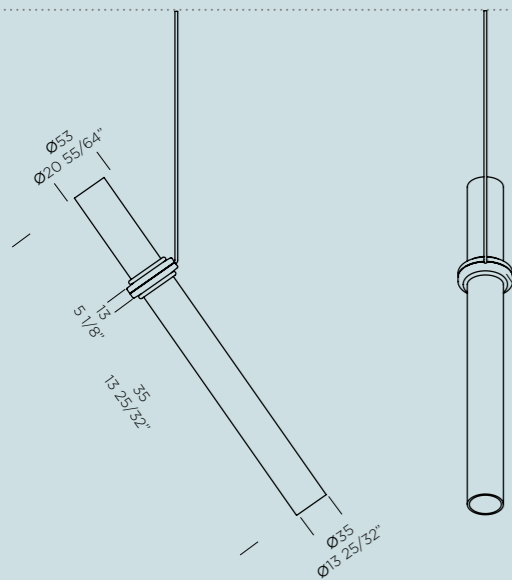

## O-LOOP

design leucos lab, 2017

### finiture/finishes

#### metal/metallo

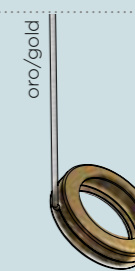

#### vetro/glass

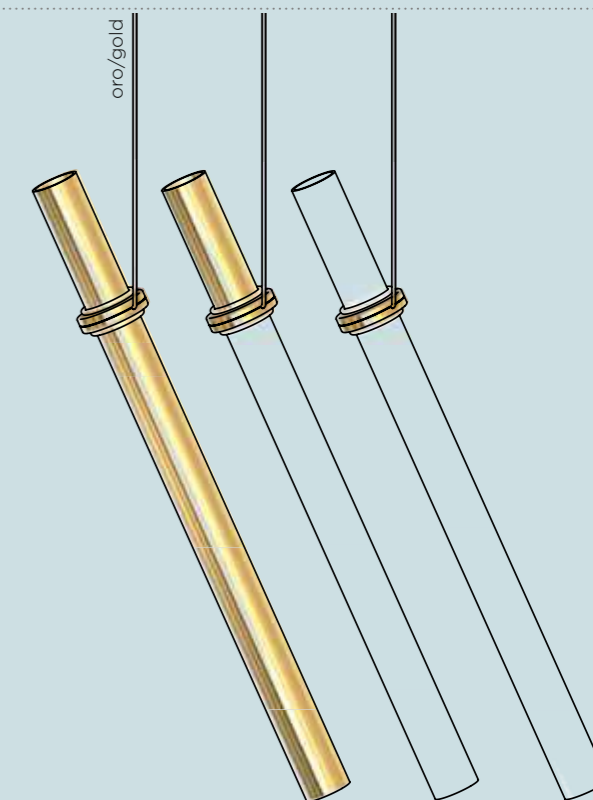
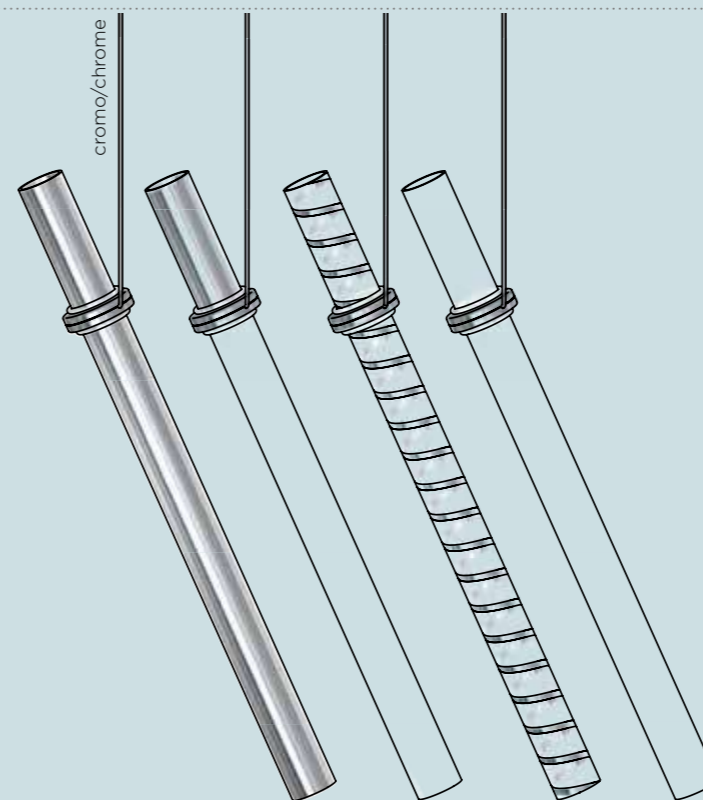

# JJ

design leucos lab, evolution 2017

## SCHEDA TECNICA/DATA SHEET

### dimensioni/dimensions

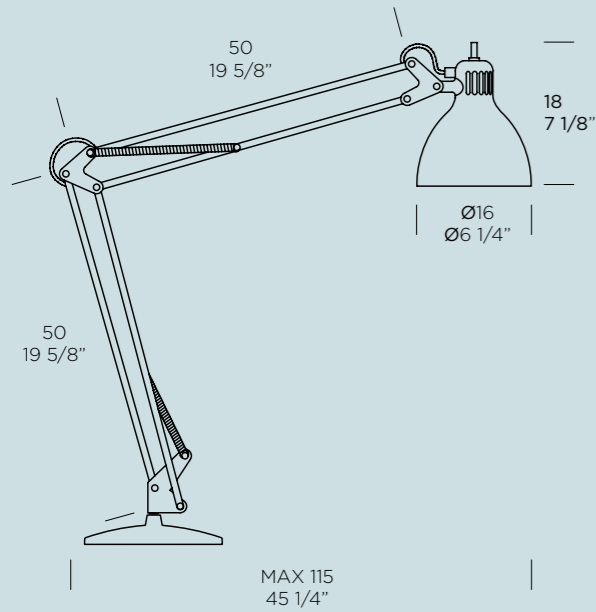

### accessori/accessories

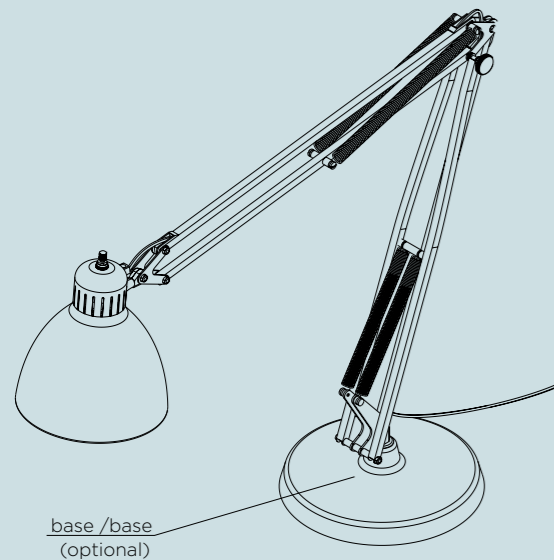

### tipologia/application

tavolo-parete/table-wall

### diffusore/diffuser

diffusore in alluminio, disponibile in dieci differenti colori/aluminium diffuser, available in ten different colours

### struttura/structure

struttura in alluminio, disponibile in dieci differenti colori/aluminium structure, available in ten different colours

### accessori/accesories

morsetto (di serie) base rotonda (opzionale), disponibile in dieci differenti colori/clamp (standard) round base (optional), available in ten different colours

### sorgente luminosa/light source

E27 MAX 46W consigliati/recommended 10W LED

### classe di isolamento/appliance class

classe II/class II

### certificazioni/certifications

CE IP 20 EAC

### note/notes

dimmerabile con pulsante esterno (pulsante esterno non fornito)/dimmable with external button (external button not supplied)

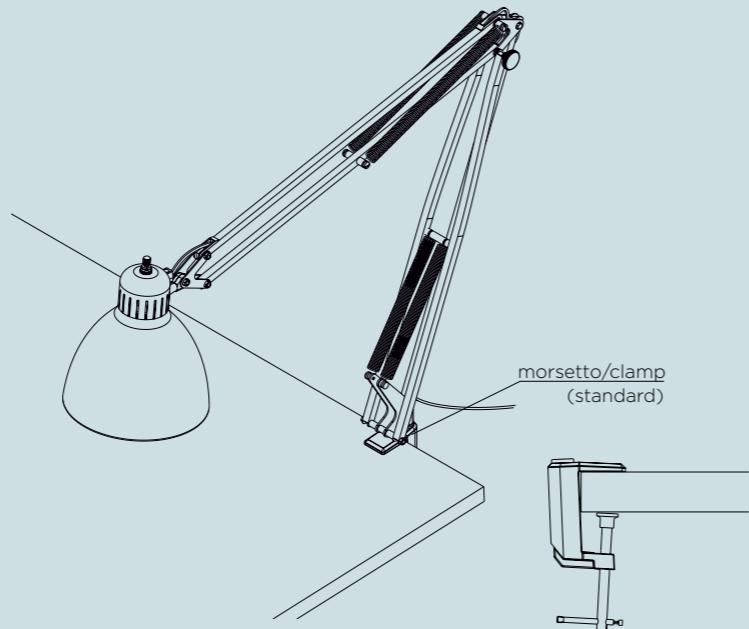

### finiture/finishes

#### metal/metallo

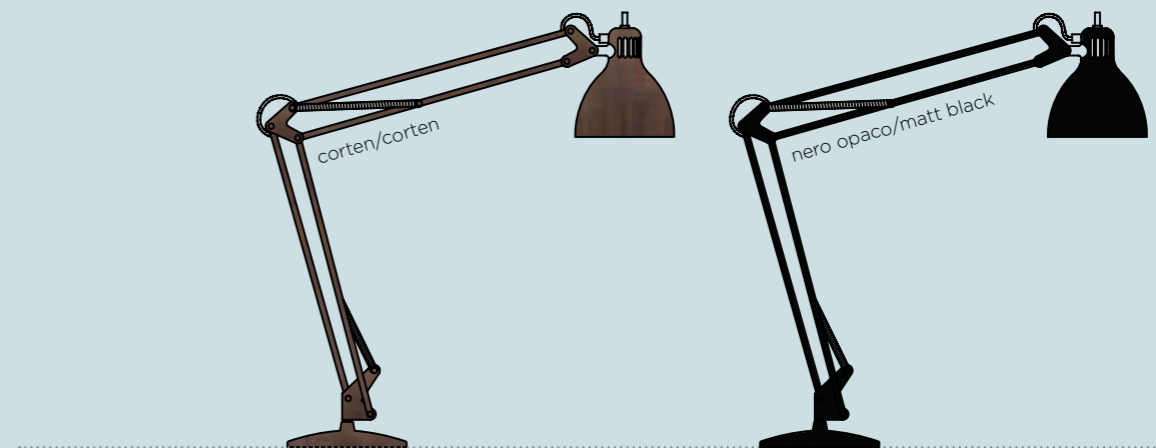
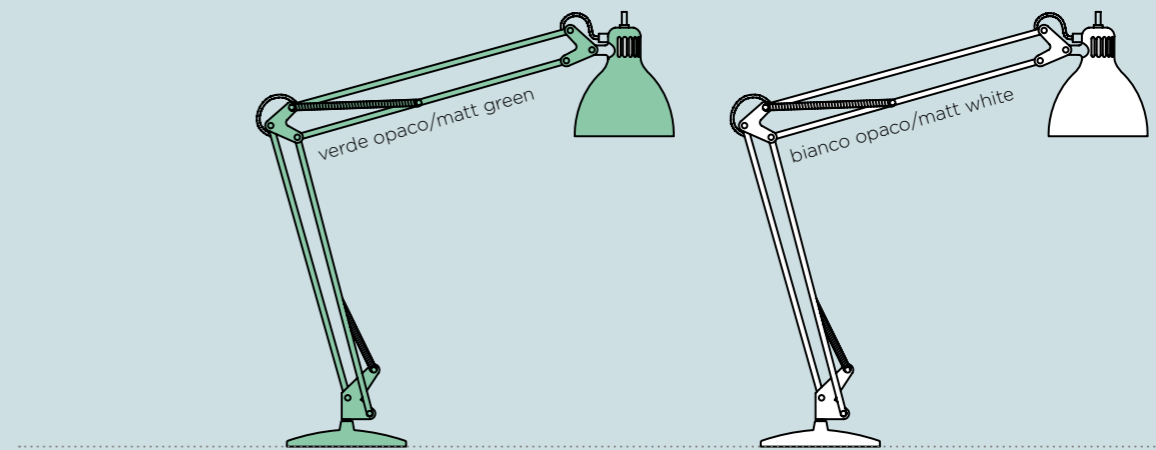



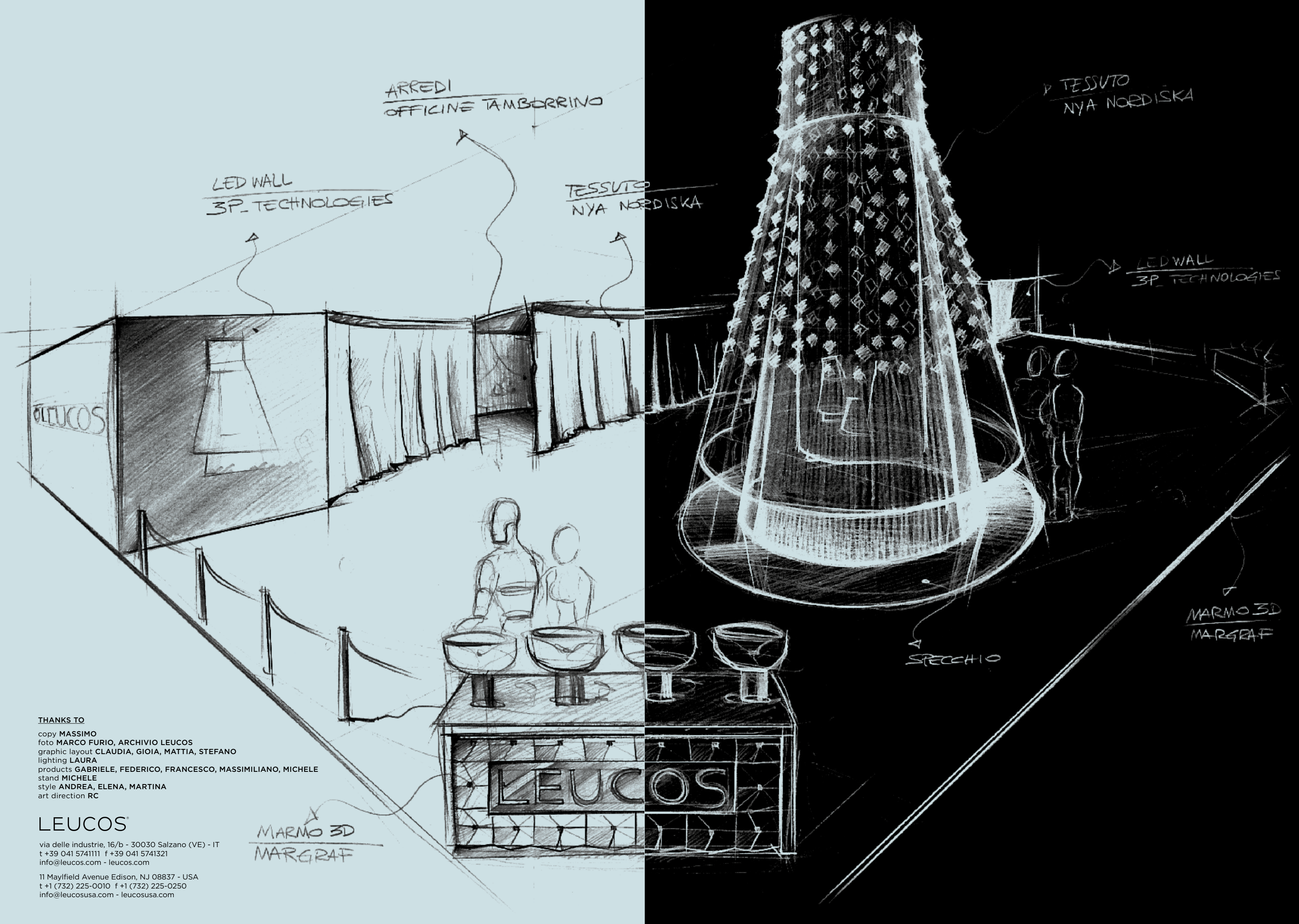

ARREDI  
OFFICINE TAMBORRINO

LED WALL  
3P. TECHNOLOGIES

TESSUTO  
NYA NORDISKA

TESSUTO  
NYA NORDISKA

LED WALL  
3P. TECHNOLOGIES

MARMO 3D  
MARGRAF

SPECCHIO

THANKS TO

copy MASSIMO  
foto MARCO FURIO, ARCHIVIO LEUCOS  
graphic layout CLAUDIA, GIOIA, MATTIA, STEFANO  
lighting LAURA  
products GABRIELE, FEDERICO, FRANCESCO, MASSIMILIANO, MICHELE  
stand MICHELE  
style ANDREA, ELENA, MARTINA  
art direction RC

LEUCOS®

via delle industrie, 16/b - 30030 Salzano (VE) - IT  
t +39 041 5741111 f +39 041 5741321  
info@leucos.com - leucos.com

11 Mayfield Avenue Edison, NJ 08837 - USA  
t +1 (732) 225-0010 f +1 (732) 225-0250  
info@leucosusa.com - leucosusa.com

MARMO 3D  
MARGRAF





**EuroLuce**



9002829



# LEUCOS®

in partnership with:



**nya nordiska**