

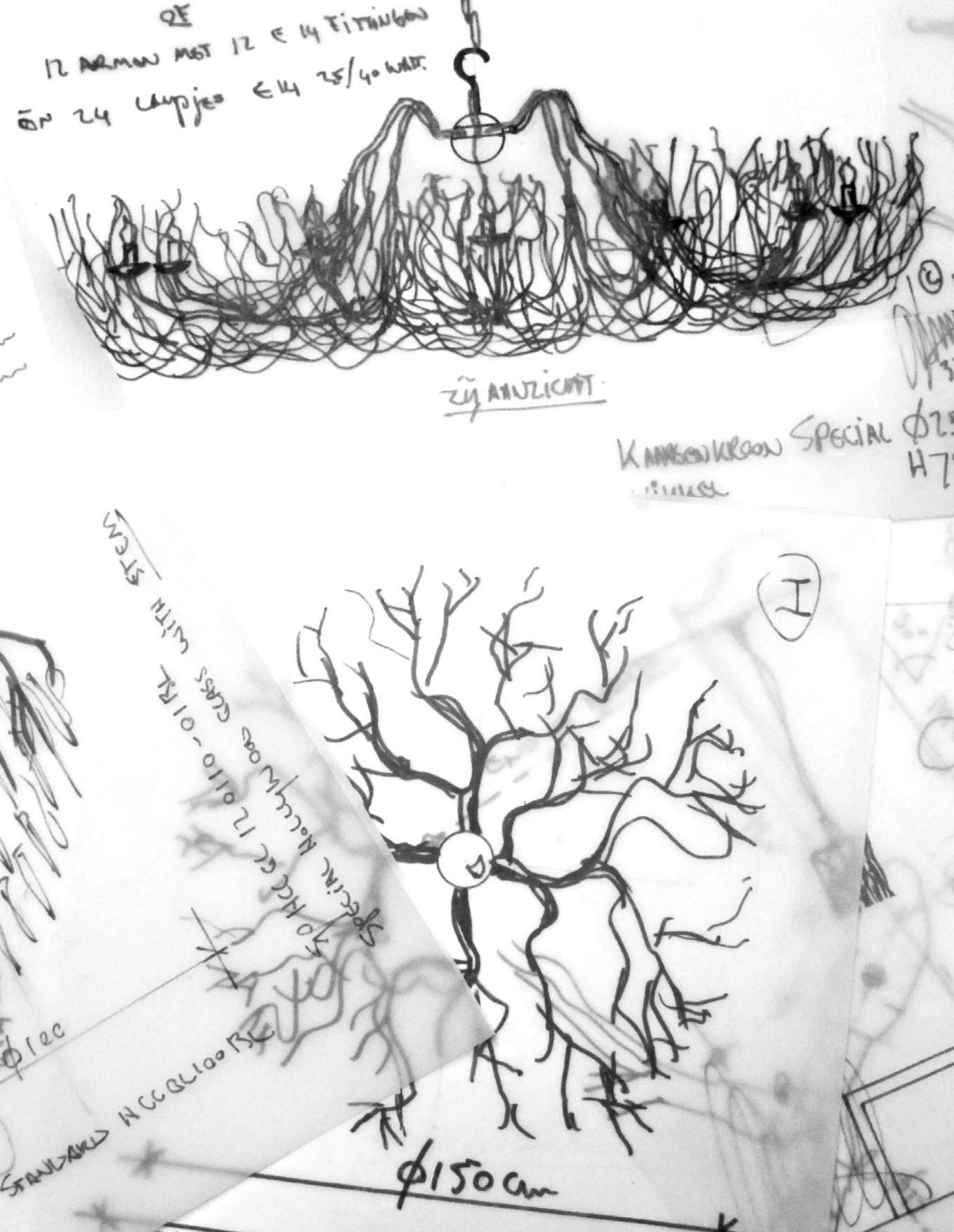

BRANDVAN
EGMOND

BRAND VAN EGMOND 2016































Welcome...

Every year we at BRAND VAN EGMOND strive to use all our knowledge and experience in order to create some of the most astounding lighting sculptures.

We are constantly inspired by the world around us, the people we meet and the beautiful projects we are invited to be part of. In return, we are frequently asked to translate unique lighting wishes into handcrafted reality.

Partners like Louis Vuitton, Chopard and the Four Seasons Hotels invited BRAND VAN EGMOND to create tailor-made lighting solutions for their spaces. We welcome everybody who wants to see our designs, or would like personal advice from William Brand and his team, to our office and ateliers in Naarden, The Netherlands.

Content

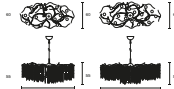
| | | | | | |
|---|-------------------------------|-----|---|---------------------|-----|
|  | HISTORY | 4 |  | LOLA | 136 |
|  | BRAND VAN EGMOND HEADQUARTERS | 6 |  | NIGHT WATCH | 140 |
|  | EVE | 8 |  | CANDLES AND SPIRITS | 146 |
|  | FRACTAL | 18 |  | FLOWER POWER | 156 |
|  | FLINTSTONE | 28 |  | ICY LADY | 164 |
|  | KELP | 32 |  | BROOM | 172 |
|  | ARTHUR | 54 |  | RHAPSODY IN BLUE | 176 |
|  | VICTORIA | 64 |  | CHRYSTAL WATERS | 180 |
|  | SULTANS OF SWING | 76 |  | DELPHINIUM | 192 |
|  | DIAMONDS FROM AMSTERDAM | 90 |  | HOLLYWOOD | 202 |
|  | TABLE D'AMIS | 94 |  | HOLLYWOOD GLASS | 226 |
|  | LA VIE EN ROSE | 102 |  | OPTIONAL FINISHES | 236 |
|  | COCO | 108 |  | CERTIFICATE | 237 |
|  | FLOATING CANDLES | 120 |  | THE DESIGNER | 238 |
|  | LOVE YOU LOVE YOU NOT | 126 |  | TECHNICAL INFO | 240 |

History

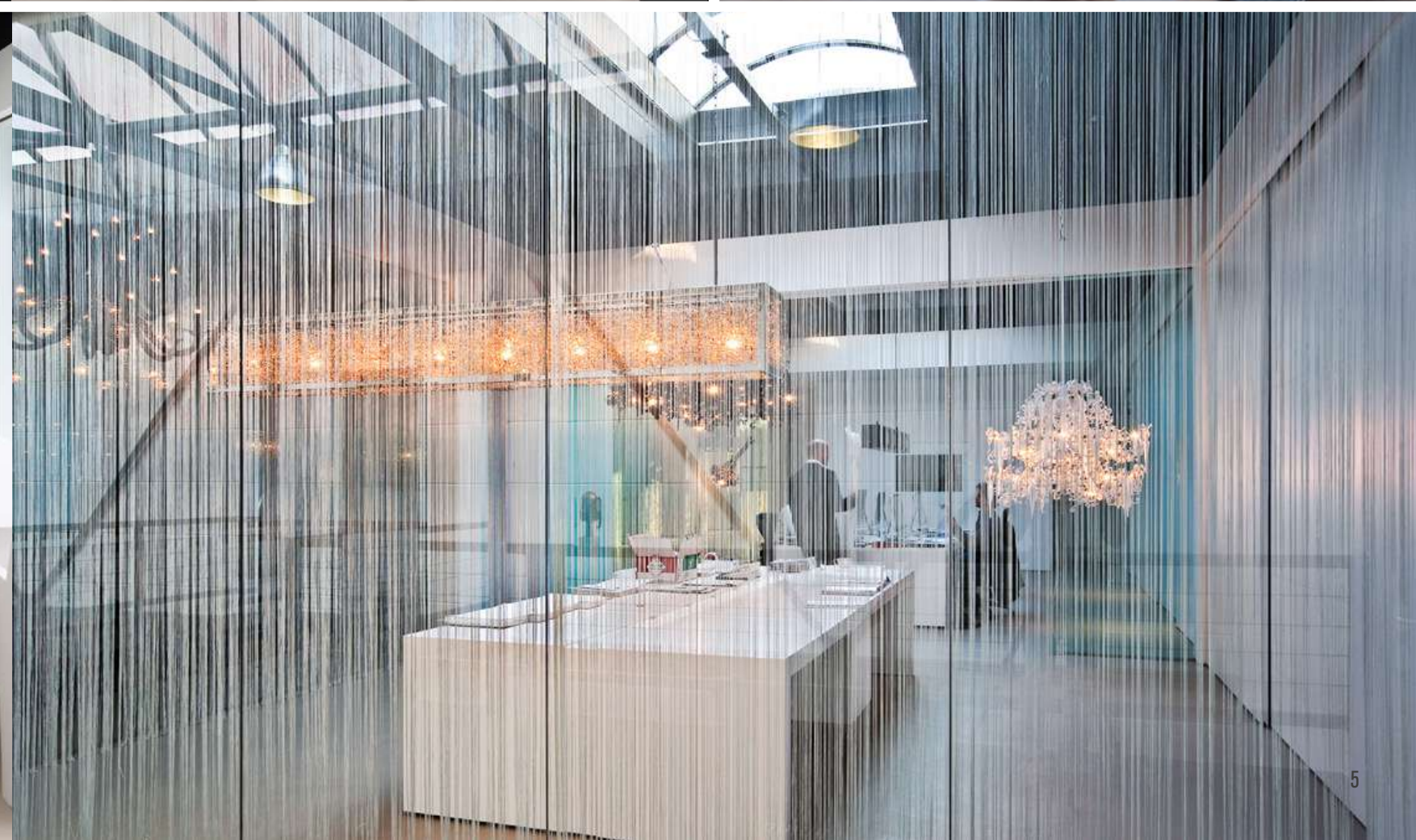

Brand van Egmond headquarters

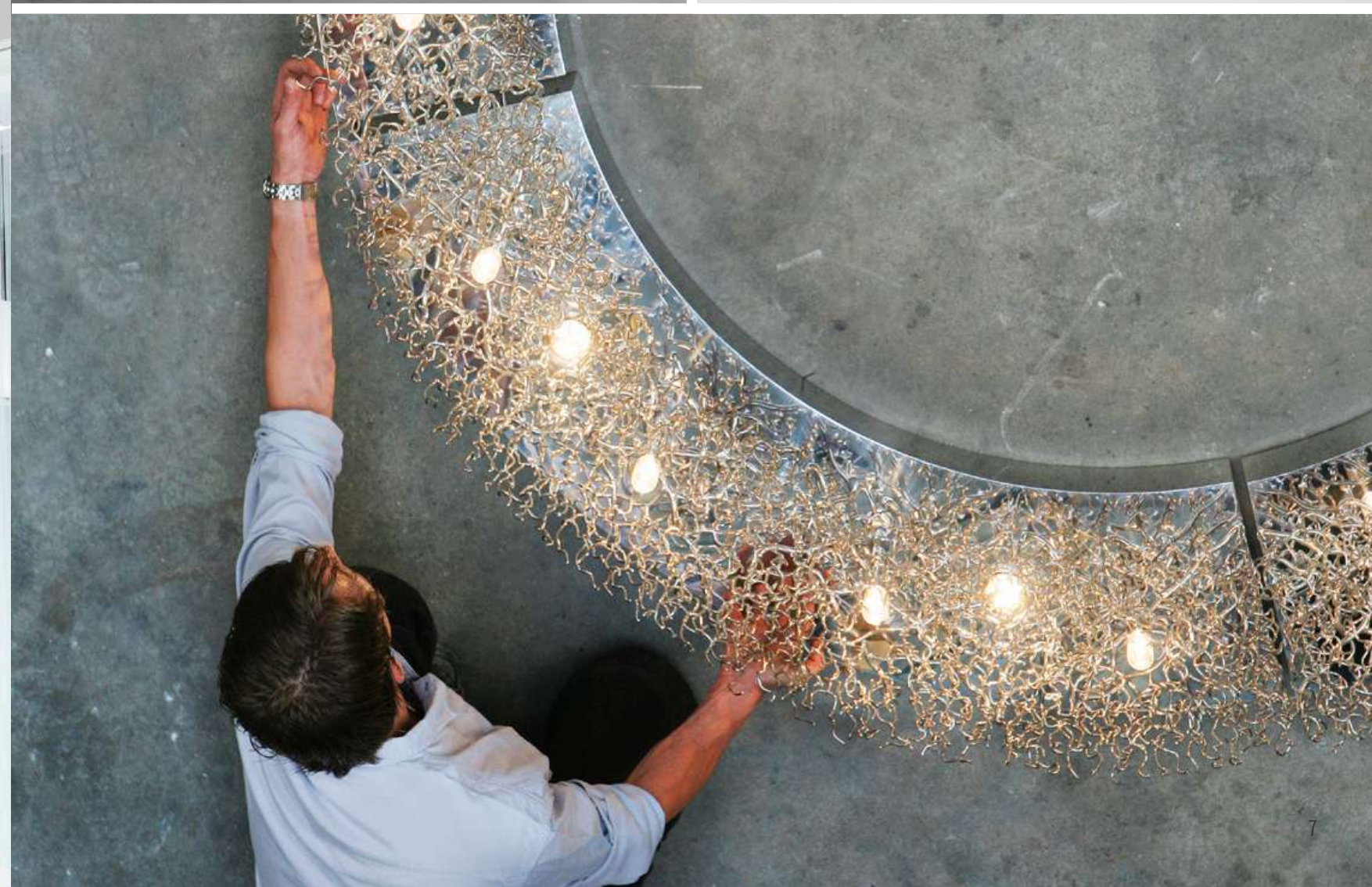

EVE

Design by William Brand

To be human, is to be aware that there are forces greater than ourselves. From the majestic power of nature, until the longings deep within our soul. With an elegant twist, although with an undeniable force behind it, the new Eve is crafted. The fruit she carries is tempting.... will the apple be eaten, or not?

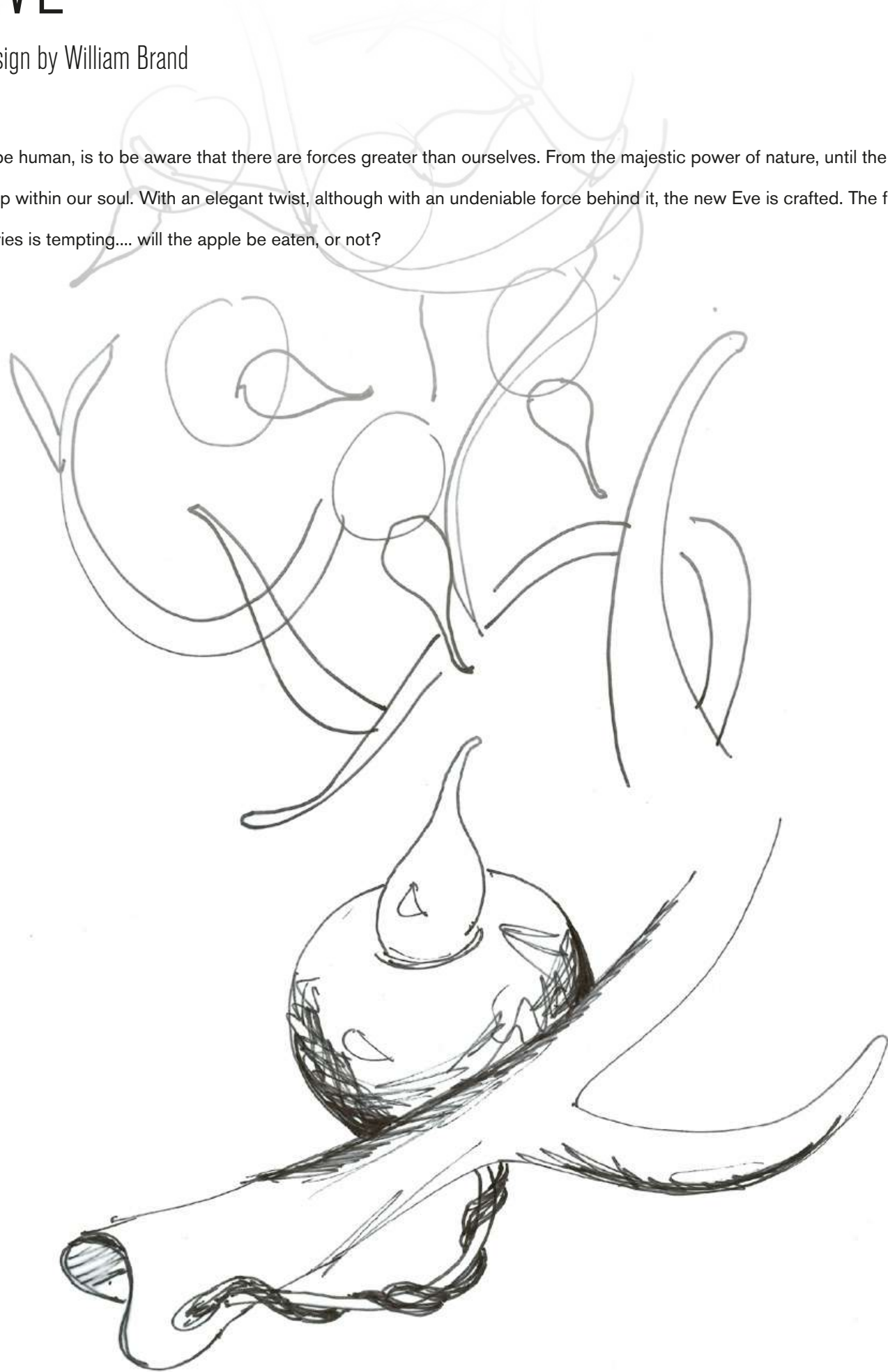

EVE CHANDELIER OVAL EVEOC140COP

Technical details page 239



EVE CHANDELIER ROUND EVEC100N
Technical details page 240



EVE CHANDELIER ROUND EVEC100COP
Technical details page 240



EVE CHANDELIER ROUND EVEC100BR
Technical details page 240



EVE CHANDELIER ROUND EVEC100COP
Technical details page 240



EVE CHANDELIER OVAL EVEOC140N
Technical details page 239



EVE CHANDELIER CONICAL EVECC70BLM-LGCOP
Technical details page 238



EVE CHANDELIER CONICAL EVECC70B-LGBR

Technical details page 238



Fractal

Design by William Brand

Our brains are set up to bring order in chaos, find logic in confusion and recognise patterns in the opaque. However, what to make of the puzzle of the exact yet endless repetition found at times around us? Fractal is a natural phenomenon as well as a mathematical set that exhibits a repeating pattern.

The organised chaos of the reflecting elements of the Fractal dispenses the light beautifully in all directions.

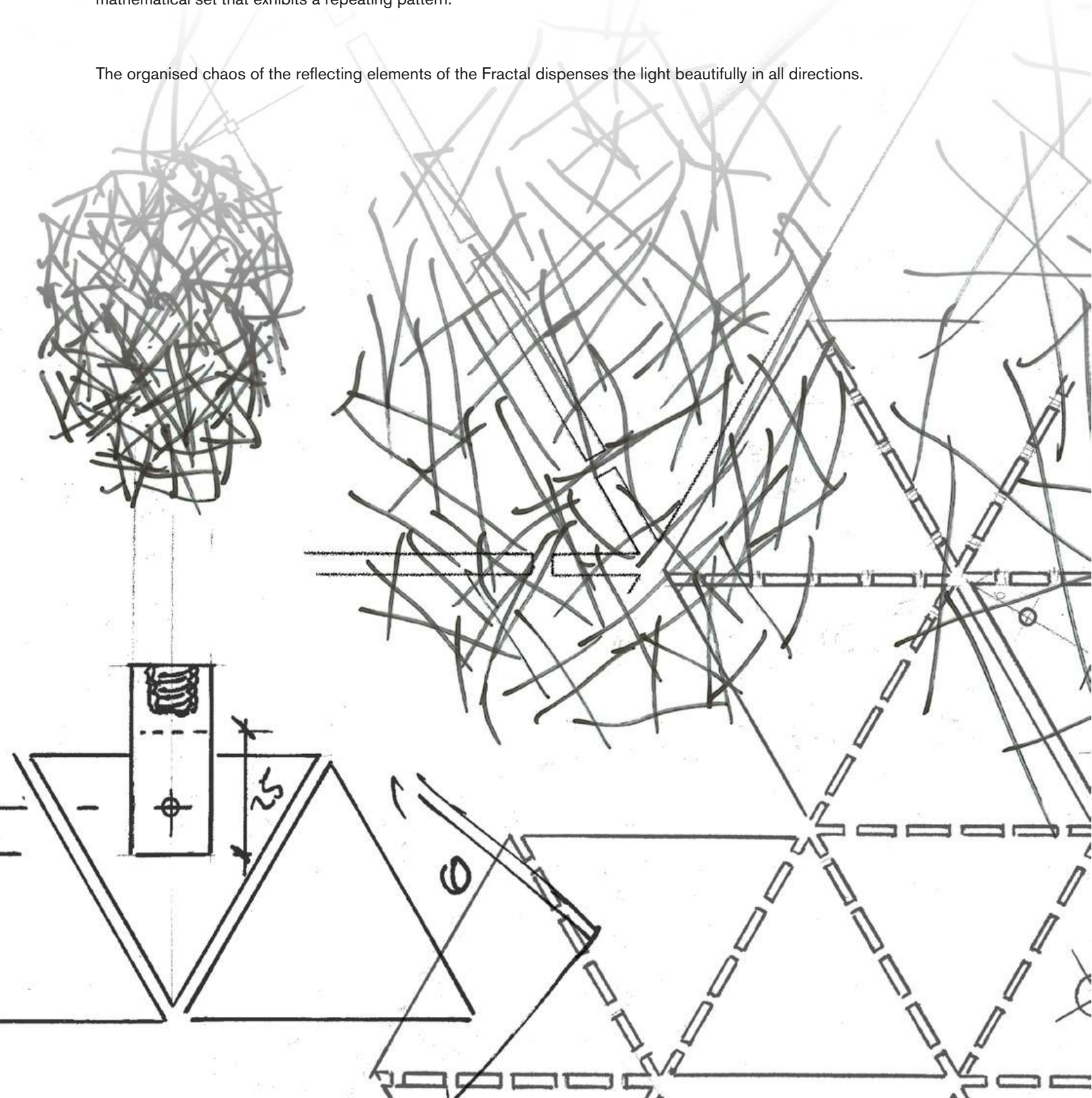



FRACTAL CHANDELIER ROUND FRACC100BRG

Technical details page 241





FRACTAL CHANDELIER ROUND FRACC80BLM

Technical details page 241

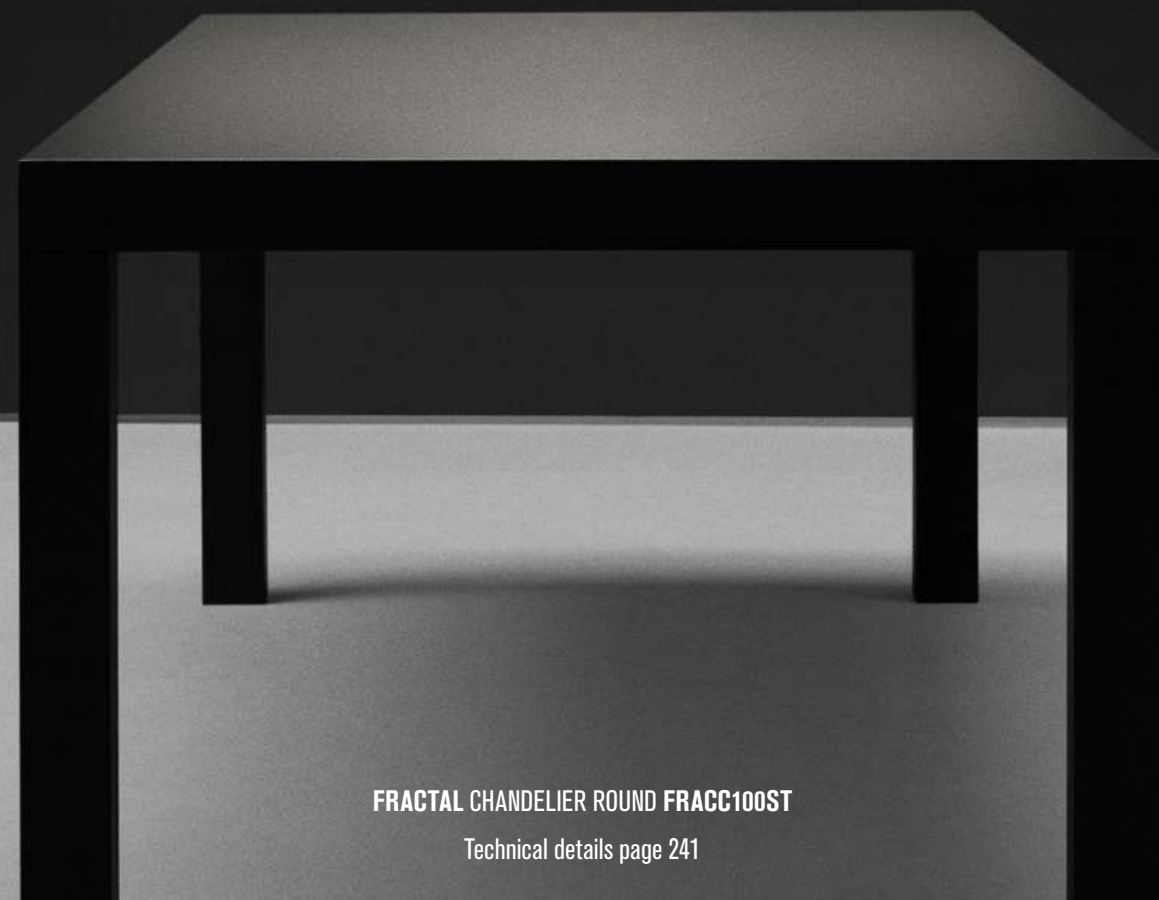

FRACTAL CHANDELIER ROUND FRACC100ST

Technical details page 241





FRACTAL HANGING LAMP CLOUD FRACHR55BLM

Technical details page 242



FRACTAL HANGING LAMP CLOUD FRACHR55BRG

Technical details page 242



FRACTAL HANGING LAMP CLOUD FRACHR55ST

Technical details page 242



FRACTAL HANGING LAMP CLOUD FRACHR55BRG

Technical details page 242



Flintstone

Design by William Brand

Retracing our steps through the millennia to the beginning of times, we find ourselves back at the fireplace in the prehistoric cave. Here we realise that the most primal of our needs are safety and warmth. The tree branch and the stone, found at the end of this journey back in time, are combined in this lighting object. Every stone is unique, and captures the emotion of eternity as well as being used as a functional counterweight.



FLINTSTONE FLOOR LAMP FLINTF130N

Technical details page 243



FLINTSTONE FLOOR LAMP FLINTF160BLM

Technical details page 243





Kelp

Design by William Brand

Kelp creates a dramatic light source which brings an exhilarating sense in the interior. You can use the object in any direction you want. A single object with a ceiling cover can create an organic light or you can form a dancing composition by entwining various lighting objects together.



KELP COMPOSITION WITH 3 SINGLE 100KELPCOP OBJECTS

Technical details page 248



DETAIL FEATURING 100KELPCOP
Technical details page 248



SINGLE KELP ELEMENT 100KELPCOP
Technical details page 248



SINGLE KELP ELEMENT 100KELPBR
Technical details page 248



SINGLE KELP ELEMENT 100KELPBR
Technical details page 248



KELP OBJECT 150KELPBLM-LGST
Technical details page 248





KELP OBJECT 25KELPCOP / LGCOP
Technical details page 248



KELP OBJECT 25KELPCOP / LGCOP
Technical details page 248



KELP COMPOSITION IN LINE BUILD OUT OF 3 X 25KELPCOP / LGCOP AND 2 X 25KELPBLM / LGCOP ELEMENTS

Technical details page 248



The Kelp is, befitting its organic form, evolving into different shapes, sizes and finishes since 2014.

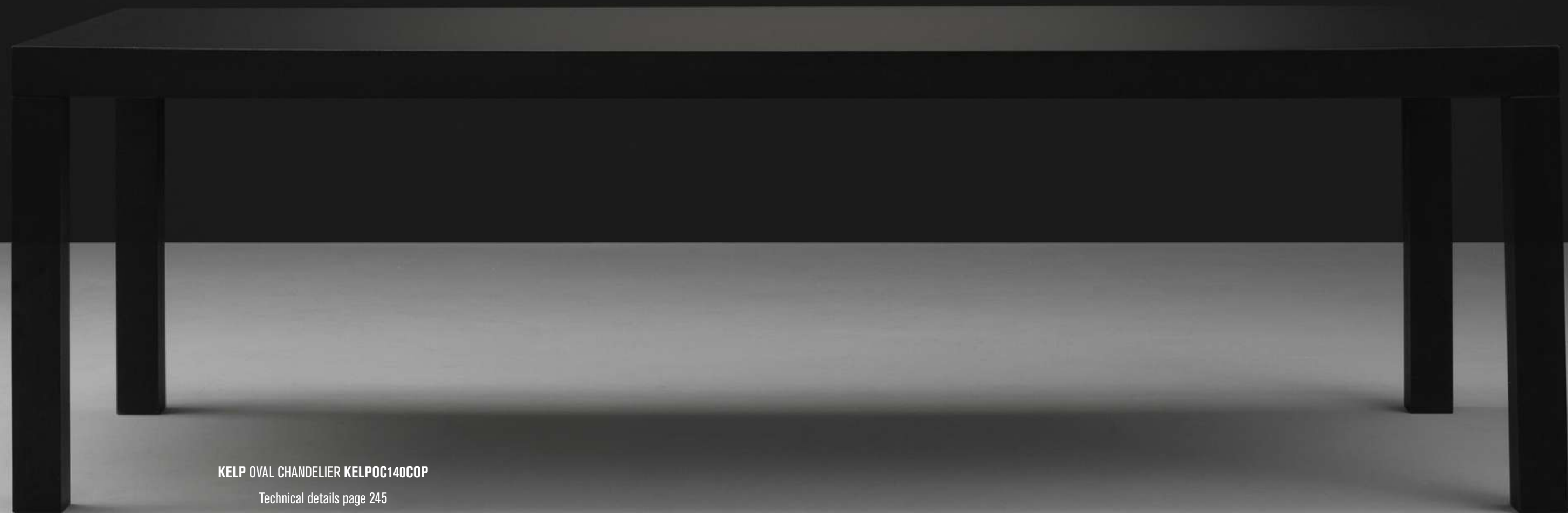

KELP OVAL CHANDELIER KELPOC140COP

Technical details page 245



KELP ROUND CHANDELIER KELPC100BR
Technical details page 246



KELP CONICAL CHANDELIER KELPCC80COP
Technical details page 244





KELP CONICAL CHANDELIER KELPCC80ST
Technical details page 244



KELP CEILING LAMP ROUND KELPP80BRG
Technical details page 247



KELP CEILING LAMP ROUND KELPP80COP
Technical details page 247

Arthur

Design by William Brand

He emerges as a conqueror when the darkness is fenced off.

Proudly overlooking the arena where he reigns.

Behind his metal curtain he shines his light

guarding everyone around.

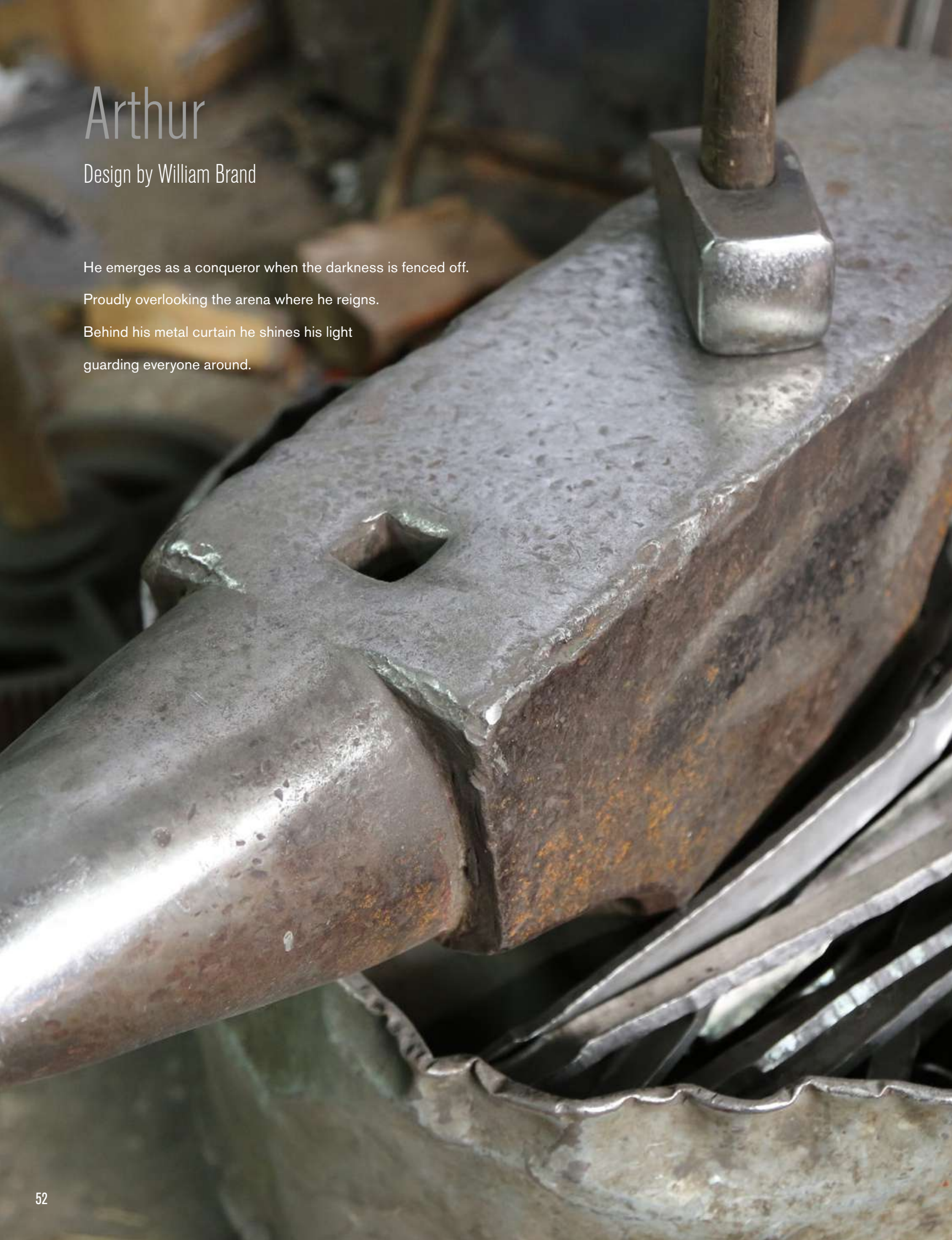

ARTHUR CHANDELIER OVAL AROC140N

Technical details page 250





DE PAUWHOF RESIDENCE WASSENAAR, NL FEATURING ARTHUR CEILING LAMP ARP80N

Technical details page 251



ARTHUR WALL LAMP ARW50N

Technical details page 252



ARTHUR HANGING LAMP SINGLE AR18N

Technical details page 252



COMPOSITION OF ARTHUR HANGING LAMP SINGLE AR18N

Technical details page 252



ARTHUR TABLE LAMP ART30N
Technical details page 252



DE PAUWHOF RESIDENCE WASSENAAR, NL FEATURING ARTHUR FLOOR LAMP ARF190N
Technical details page 252

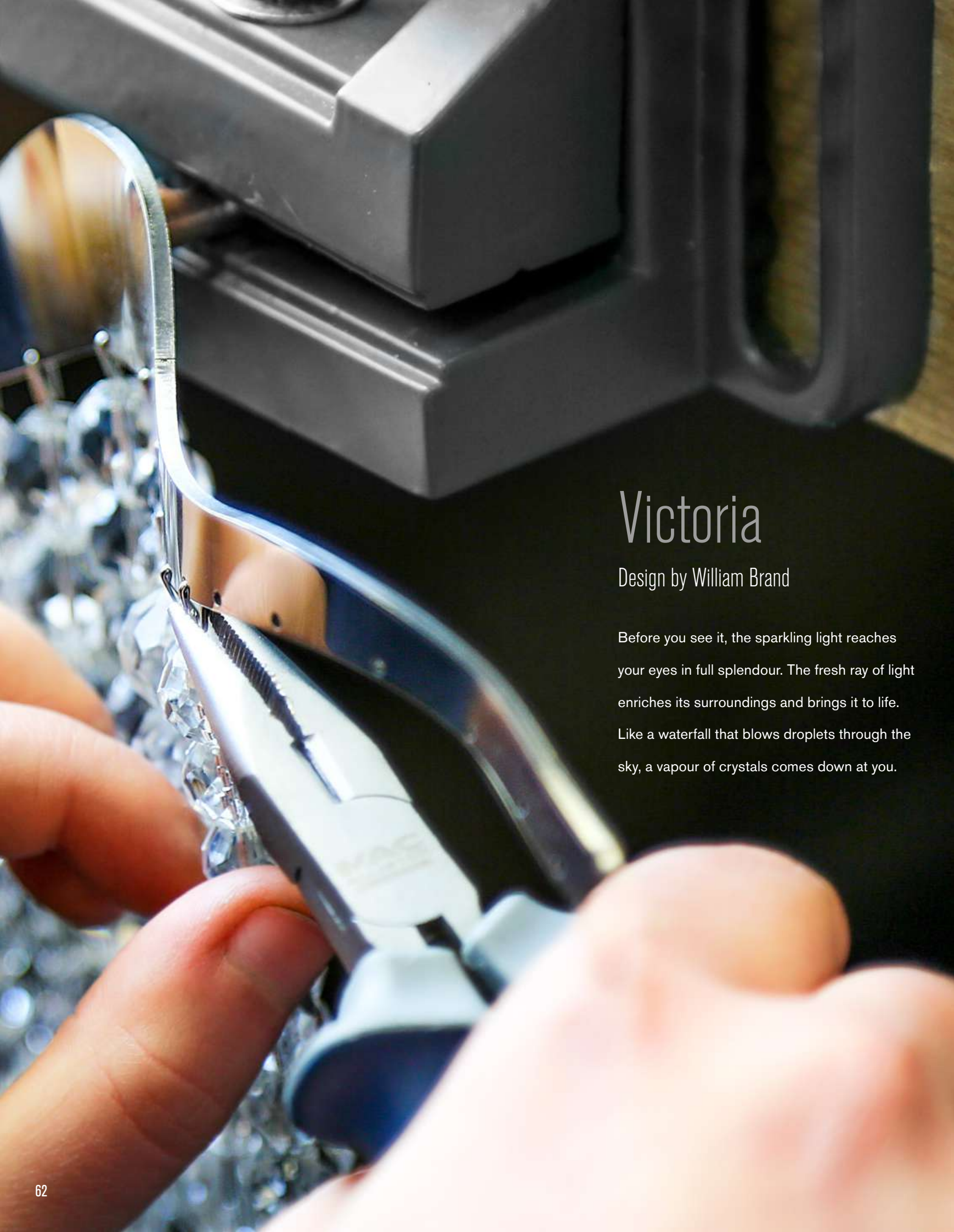

Victoria

Design by William Brand

Before you see it, the sparkling light reaches your eyes in full splendour. The fresh ray of light enriches its surroundings and brings it to life. Like a waterfall that blows droplets through the sky, a vapour of crystals comes down at you.



VICTORIA CHANDELIER ROUND VC100N

Technical details page 254



VICTORIA CHANDELIER CONICAL VCC70N
Technical details page 253



VICTORIA CEILING LAMP VP80N



VICTORIA CEILING LAMP VP60N
Technical details page 254

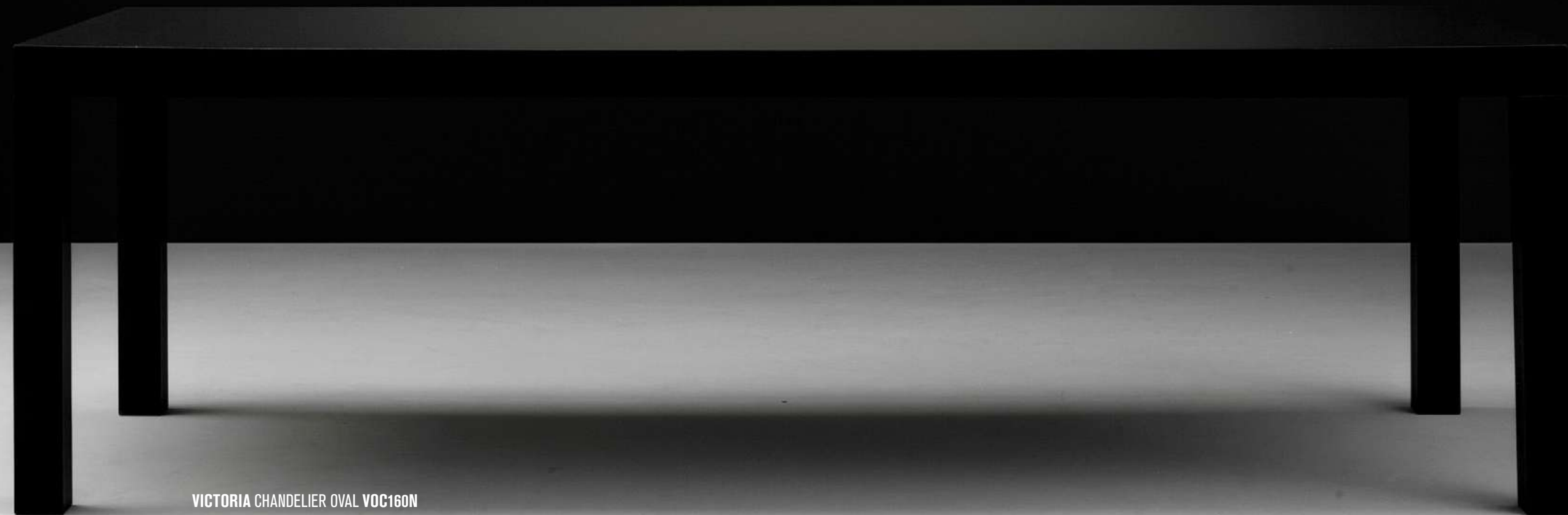

VICTORIA CHANDELIER OVAL VOC160N

Technical details page 253



VICTORIA TABLE LAMP VT30N
Technical details page 255

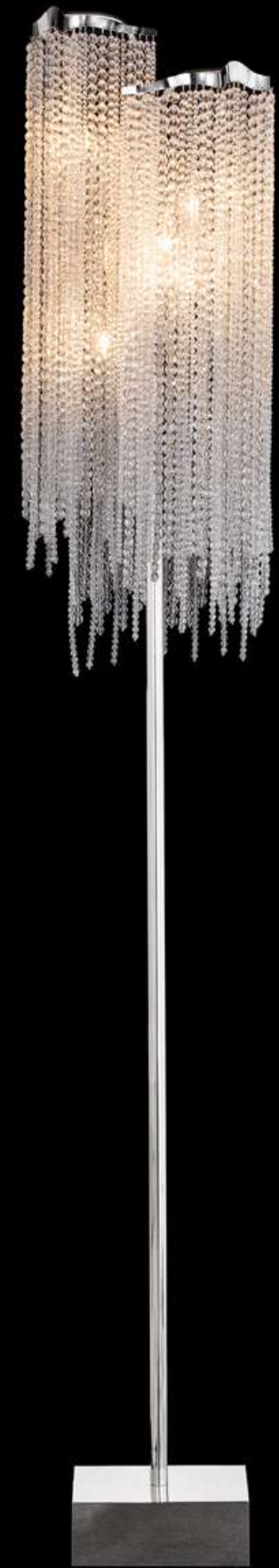

VICTORIA FLOOR LAMP VF190N
Technical details page 255



VICTORIA WALL LAMP VW50N
Technical details page 255



VICTORIA WALL LAMP VW50N AND VW70N
Technical details page 255



VICTORIA HANGING LAMP SINGLE VC18N

Technical details page 255



COMPOSITION OF VICTORIA HANGING LAMP SINGLE VC18N

Technical details page 255

Sultans of Swing

Design by William Brand

Beauty enables us to find and lose ourselves at the same time. Only when paying careful attention, we sometimes hear the quiet whispers of history from beyond the curtain of time. Embracing both times gone by as well as the present, Sultans of Swing captures Imperial elegance and the sheer pleasure of blowing new life into long-standing shapes and forms.



SULTANS OF SWING CHANDELIER ROUND SOS100N

Technical details page 257



SULTANS OF SWING CHANDELIER OVAL SOSOC140N

Technical details page 256



SULTANS OF SWING HANGING LAMP LONG SOSH140N

Technical details page 257



DESSANGE SALON MOSCOW, RU FEATURING SULTANS OF SWING CHANDELIER CONICAL SOSCC80N

Technical details page 256



SULTANS OF SWING CHANDELIER CONICAL SOSCC80N

Technical details page 256



SULTANS OF SWING CEILING LAMP ROUND SOSP80N



SULTANS OF SWING CEILING LAMP ROUND SOSP60N

Technical details page 258



PRIVATE INTERIOR THE HAGUE, NL FEATURING SULTANS OF SWING TABLE LAMP SOST65N

Technical details page 258



SULTANS OF SWING WALL LAMP SOSW36N

Technical details page 258



SULTANS OF SWING WALL LAMP SOSW50N

Technical details page 258

Our Sultans of Swing 'Adagio' can be shaped and formed to your needs.

You can select from four different single light objects, each with its own characteristic shaped curls.

You can use them by itself or combine them to fit your needs.



SULTANS OF SWING 'ADAGIO' SINGLES WITH VARIOUS CURVES 100SOSST

Technical details page 259



SULTANS OF SWING 'ADAGIO' SINGLES WITH VARIOUS CURVES 100SOSST

Inspirational rendering single lamps in a random combination



SULTANS OF SWING 'ADAGIO' SINGLES WITH VARIOUS CURVES 100S0SST
inspirational rendering single lamps in a random combination



SULTANS OF SWING 'ADAGIO' SINGLES WITH VARIOUS CURVES 100S0SST
Technical details page 259



Diamonds from Amsterdam

Design by Annet van Egmond

Rough and unpolished stones, mined from deep beneath the surface, have for many years been brought to Amsterdam, the City of Diamonds.

Only there do they receive their clarity, colourful light and final shape. Experience the romantic resonance and splendour of heritage jewellery through this lighting object.



PRIVATE INTERIOR, BE FEATURING DIAMONDS FROM AMSTERDAN HANGING LAMP ROUND DFAC80ST. A PROJECT BY VERLICHTING.BE BVBA

Technical details page 260



PRIVATE INTERIOR, BE FEATURING DIAMONDS FROM AMSTERDAN HANGING LAMP ROUND DFAC80ST. A PROJECT BY VERLICHTING.BE BVBA

Technical details page 260



PRIVATE INTERIOR, NL FEATURING DIAMONDS FROM AMSTERDAN HANGING LAMP ROUND DFAC80ST.

INTERIOR DESIGN BY DESIGNA, LEATHER FLOORING BY ALPHENBERG - Technical details page 260



Table d'Amis

Design by William Brand

Life is partly what we make of it, and partly made by the friends we choose. Capturing the feelings of an intimate and fun dinner party with loved ones, the Table d'Amis was at first created as a gift for a special family friend of William and Annet's.



CUSTOMISED TABLE D'AMIS HANGING LAMP
LENGTH 35 CM, WIDTH 35 CM, HEIGHT 42 CM



TABLE D'AMIS HANGING LAMP LONG TABL135BLM

Technical details page 261

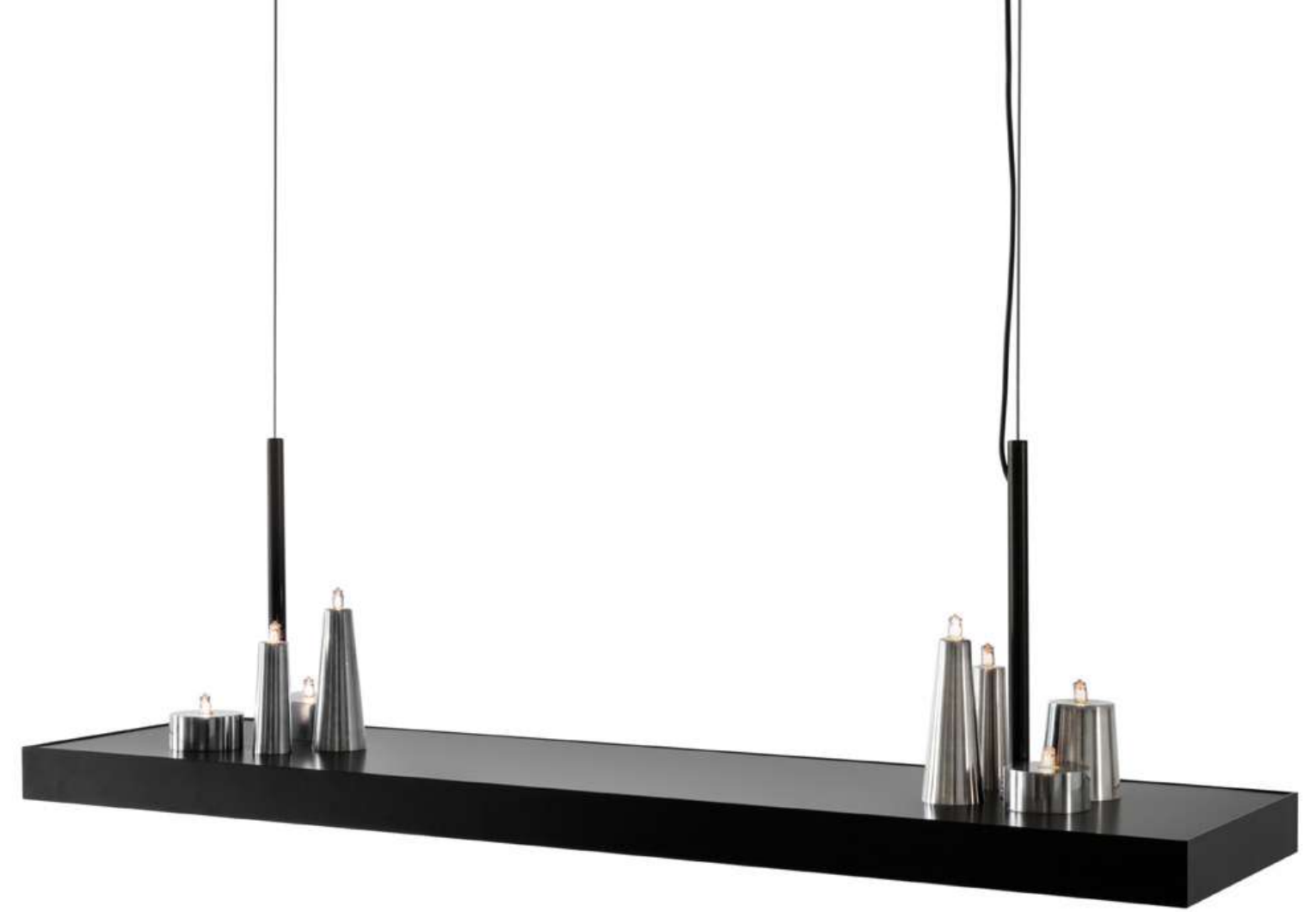

TABLE D'AMIS HANGING LAMP LONG TABL135BLM

Technical details page 261



PRIVATE INTERIOR, NL FEATURING TABLE D'AMIS HANGING LAMP LONG CUSTOMISED
LENGTH 300 CM, WIDTH 35 CM, HEIGHT 42 CM

La Vie en Rose

Design by William Brand

Regardless of our background, we all understand the language of beauty and tenderness.

In every corner of the world, the gift of a bouquet of flowers is answered with a smile.

What more to ask for, what else to give?

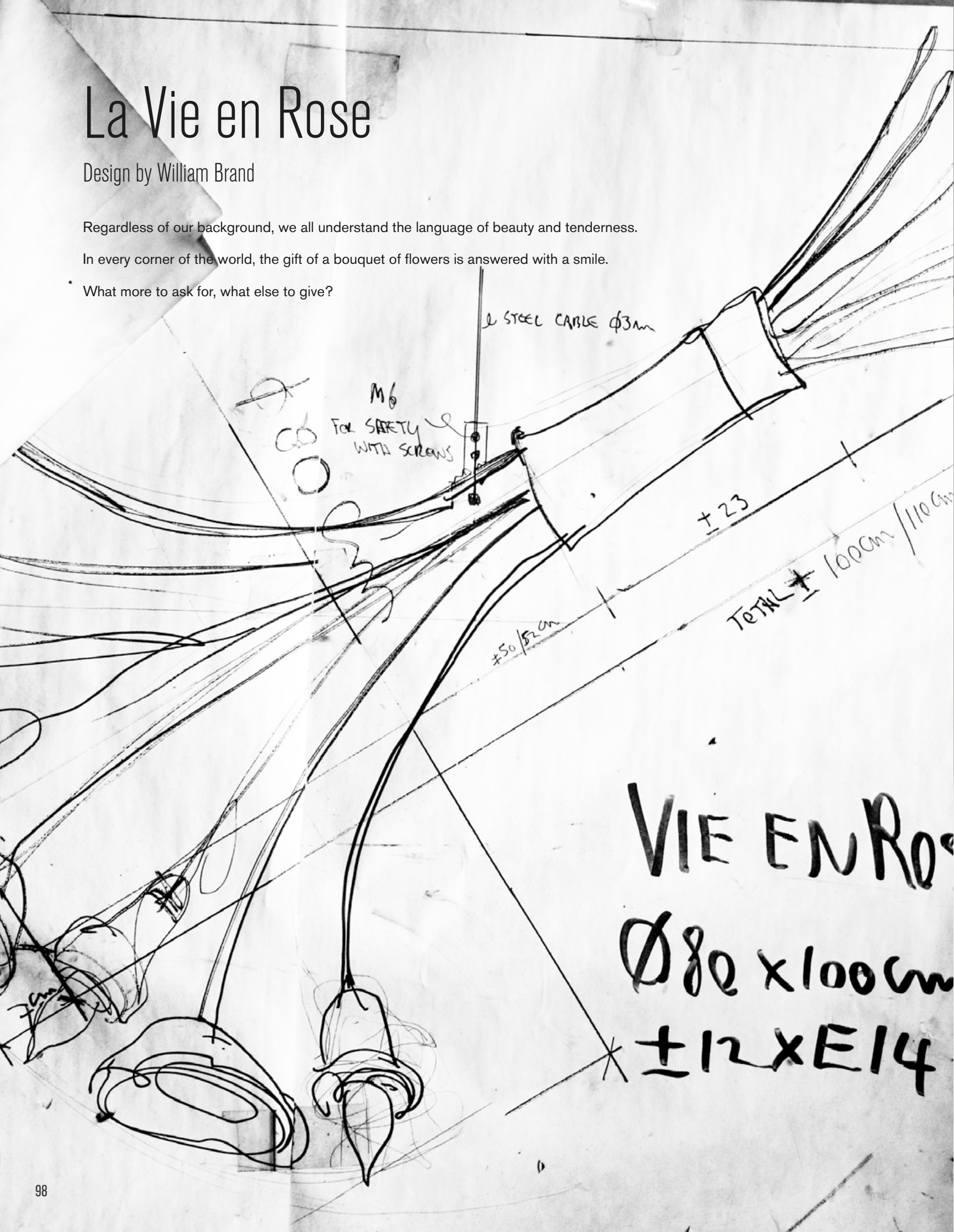

VIE EN ROSE
Ø80 x 100cm
±12 x E14





LA VIE EN ROSE COMPOSITION CUSTOMISED

Example of different compositions, all combinations possible - Technical details page 262

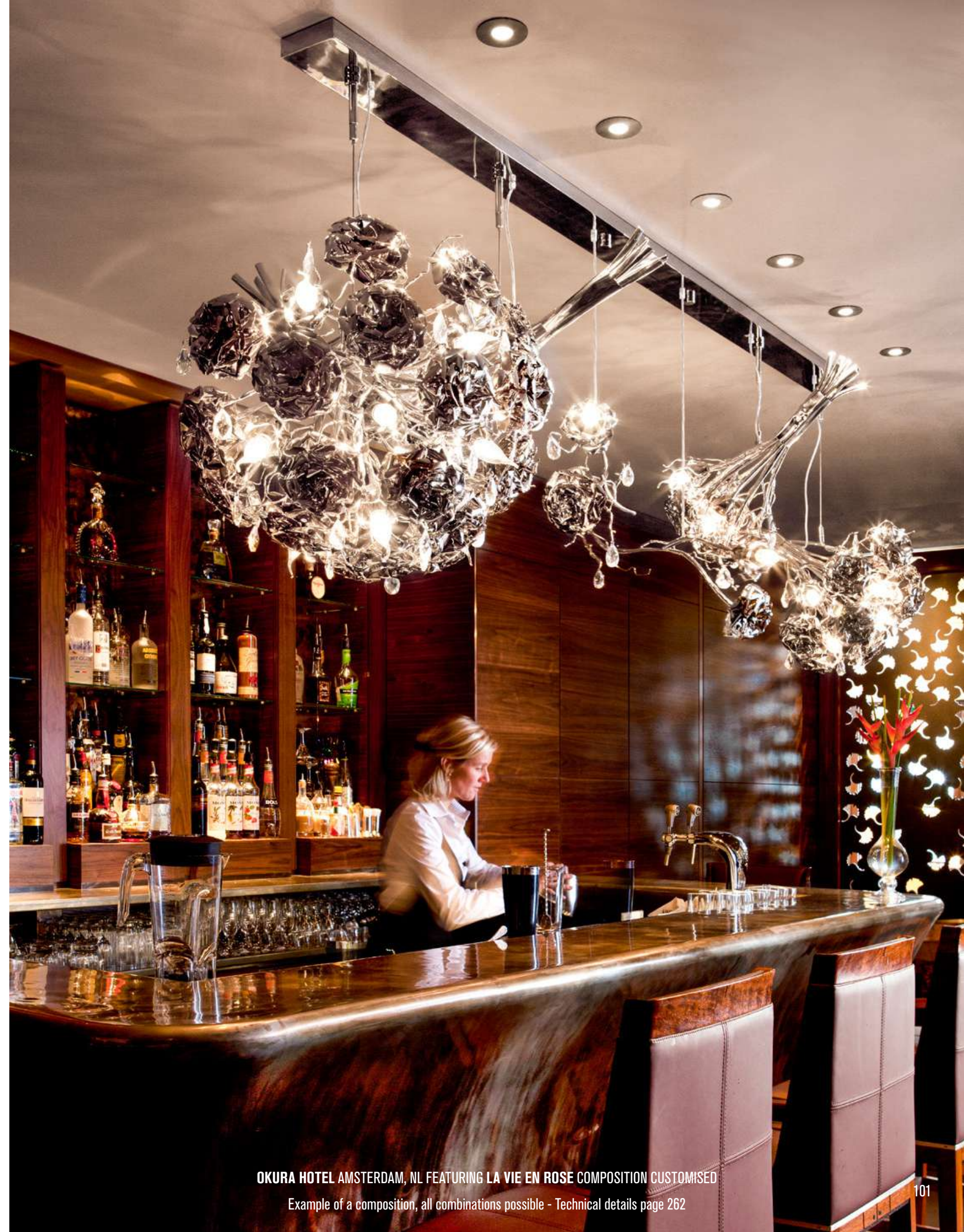

OKURA HOTEL AMSTERDAM, NL FEATURING LA VIE EN ROSE COMPOSITION CUSTOMISED

Example of a composition, all combinations possible - Technical details page 262



LA VIE EN ROSE HANGING LAMP VERHL120N
Technical details page 263



LA VIE EN ROSE WALL LAMP VERW35N
Technical details page 263

Coco

Design by William Brand

The strings of deep black and clear crystals, loosely tied around her wrist and neck, fall in a spontaneous and playful way.

Coco brings fashion and design together. Keep your eyes wide shut... can you handle a flirt with Coco?





COCO CHANDELIER ROUND COCOCC60N

Technical details page 264



DOGAPPEL OPTICIAN AMSTERDAM, NL FEATURING COCO CHANDELIER ROUND COCOCC100N

Technical details page 264



COCO CHANDELIER ROUND COCOCC80BL

Technical details page 264



COCO CHANDELIER ROUND COCOCC100N

Technical details page 264



COCO CHANDELIER ROUND COCOCC120N

Technical details page 264



COCO CHANDELIER ROUND COCOCC80N

Technical details page 264



COCO CHANDELIER CUSTOMISED ROUND
Ø90 cm H. 200 cm, 22x E14, nickel finish



KONINGSKINDEREN DAY CARE: DE BERENPELS BUSSUM, NL FEATURING COCO CEILING LAMP COCOP80N AND COCOW36N-L

Technical details page 265



COCO WALL LAMP COCOW36N-L
Technical details page 265



COCO WALL LAMP COCOW35BL
Technical details page 207



COCO WALL LAMP COCOW35N
Technical details page 265



Floating Candles

Design by William Brand

Bare and with all extravagance cut away, Floating Candles is the quintessential expression of light. Through this design the very foundation of light is revisited, leading to a simple yet iconic object.



FLOATING CANDLES HANGING LAMP INLINE FCB18STXFCDL18ST2XIL

Technical details page 267



FLOATING CANDLES HANGING LAMP INLINE FCB18ST

Technical details page 268



FLOATING CANDLES HANGING LAMP INLINE FCB18WM3XFCDL18WM2XIL

Technical details page 267



FLOATING CANDLES COMPOSITION CUSTOMISED
EXAMPLE OF A COMPOSITION, ALL COMBINATIONS POSSIBLE - Technical details page 268



FLOATING CANDLES WALL LAMP DOWNLIGHT FCDLW36ST

Technical details page 268



Love You Love You Not

Design by William Brand

The rose, while the icon of love, also symbolises the thin line between love gained and love lost. It's out of your hands, pick the petals at random, and wonder; she loves me, she loves me not . . .



PRIVATE INTERIOR, BUSSUM, NL FEATURING LOVE YOU LOVE YOU NOT CHANDELIER CONICAL LYCC70N

Technical details page 269





KONINGSKINDEREN DAY CARE BUSSUM, NL FEATURING LOVE YOU LOVE YOU NOT CHANDELIER CONICAL CUSTOMISED

ø 120 cm, Height 120 cm, white finish



CUSTOMISED LOVE YOU LOVE YOU NOT CHANDELIER OVAL LYOC80B

Technical details page 270



LOVE YOU LOVE YOU NOT WALL LAMP LYCB75W AND LYCB55N

Technical details page 270



PRIVATE INTERIOR SHANGHAI, CN FEATURING LOVE YOU LOVE YOU NOT CHANDELIER ROUND LYCB75N

A project by H.N. Lin - Technical details page 270



KONINGSKINDEREN DAY CARE: DE STERREDAALDERS BUSSUM, NL FEATURING LOVE YOU LOVE YOU NOT CEILING LAMP LYP100W

Technical details page 271



KONINGSKINDEREN DAY CARE BUSSUM, NL FEATURING LOVE YOU LOVE YOU NOT WALL LAMP LYW45W-L AND LYW45W-R

Technical details page 271

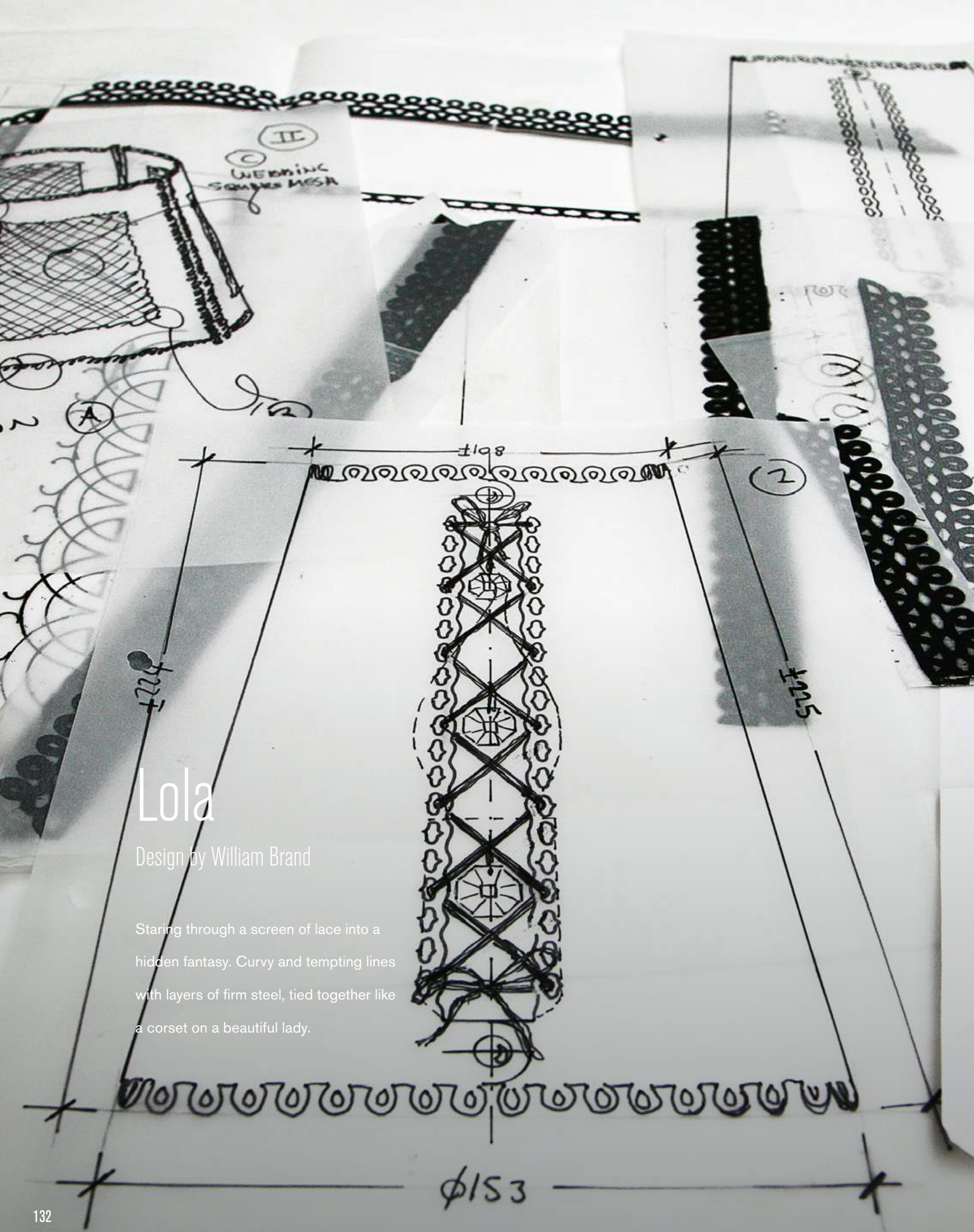

Lola

Design by William Brand

Staring through a screen of lace into a hidden fantasy. Curvy and tempting lines with layers of firm steel, tied together like a corset on a beautiful lady.



LOLA CHANDELIER ROUND LLCCR100BLM

Technical details page 272



LOLA WALL LAMP LLW20ST
Technical details page 272



LOLA CHANDELIER ROUND LLCCR100WM
Technical details page 272



Night Watch

Design by William Brand

The Night Watch collection was created to pay homage to the seventeenth century painter Rembrandt van Rijn. Simple and bare, yet glowing and warm, it reaches back to the early copper chandeliers found in Rembrandt's paintings, bringing tradition into today's space.



NIGHT WATCH CHANDELIER ROUND NWH75BLM

Technical details page 273



GREY D'ALBION, PUERTO BANUS, MARBELLA, ES, FEATURING NIGHT WATCH CHANDELIER ROUND NWH95ST

Technical details page 273



HET ARSENAAL NAARDEN, NL FEATURING CUSTOMISED NIGHT WATCH CHANDELIER ROUND NWH140BLM

Technical details page 273



PRIVATE INTERIOR ALGARVE, PT FEATURING NIGHT WATCH WALL LAMP NWW17ST AND CHANDELIER ROUND NWH60ST.
A PROJECT BY ALGARVE ARCHITECTURE - Technical details page 273



NIGHT WATCH WALL LAMP NWW17ST
Technical details page 273



Candles and Spirits

Design by William Brand

Reaching out from the present to the past, allowing the echo of history to influence our hand while drawing and merging this with the very best crystals. The hand can, after all, never achieve anything higher than the heart can inspire.





DUTCH EMBASSY MOSCOW, RU FEATURING CANDLES AND SPIRITS CHANDELIER ROUND CASH120NH

Technical details page 274



HOTEL BRANDENBURGER HOF BERLIN, DE FEATURING CANDLES AND SPIRITS CHANDELIER ROUND CASH90NH

Technical details page 274



CANDLES AND SPIRITS WALL LAMP CASW40NH

Technical details page 275



CANDLES AND SPIRITS DETAIL

The single light object from our Candles and Spirits
'Squadra' is considerable bigger than its baby sister from
our collection. Because of its size, it deserves a generous
location where it can reach its full potential. A single
light object with a ceiling cover can be used on its own
or create a more lavish lighting sculpture with multiple
objects in a horizontal or vertical composition.



CANDLES AND SPIRITS 'SQUADRA' SINGLE 50CASHN

Technical details page 275



INSPIRATION RENDERING FEATURING CANDLES AND SPIRITS 'SQUADRA' COMPOSITION WITH 10 SINGLES



Flower Power

Design by William Brand

Using the latest techniques to cut flowery sensual shapes out of steel plates, Flower Power is a wonderful rendez-vous between handmade and high-tech. All this is combined with especially designed glass drops, that evoke the idea of icicles.

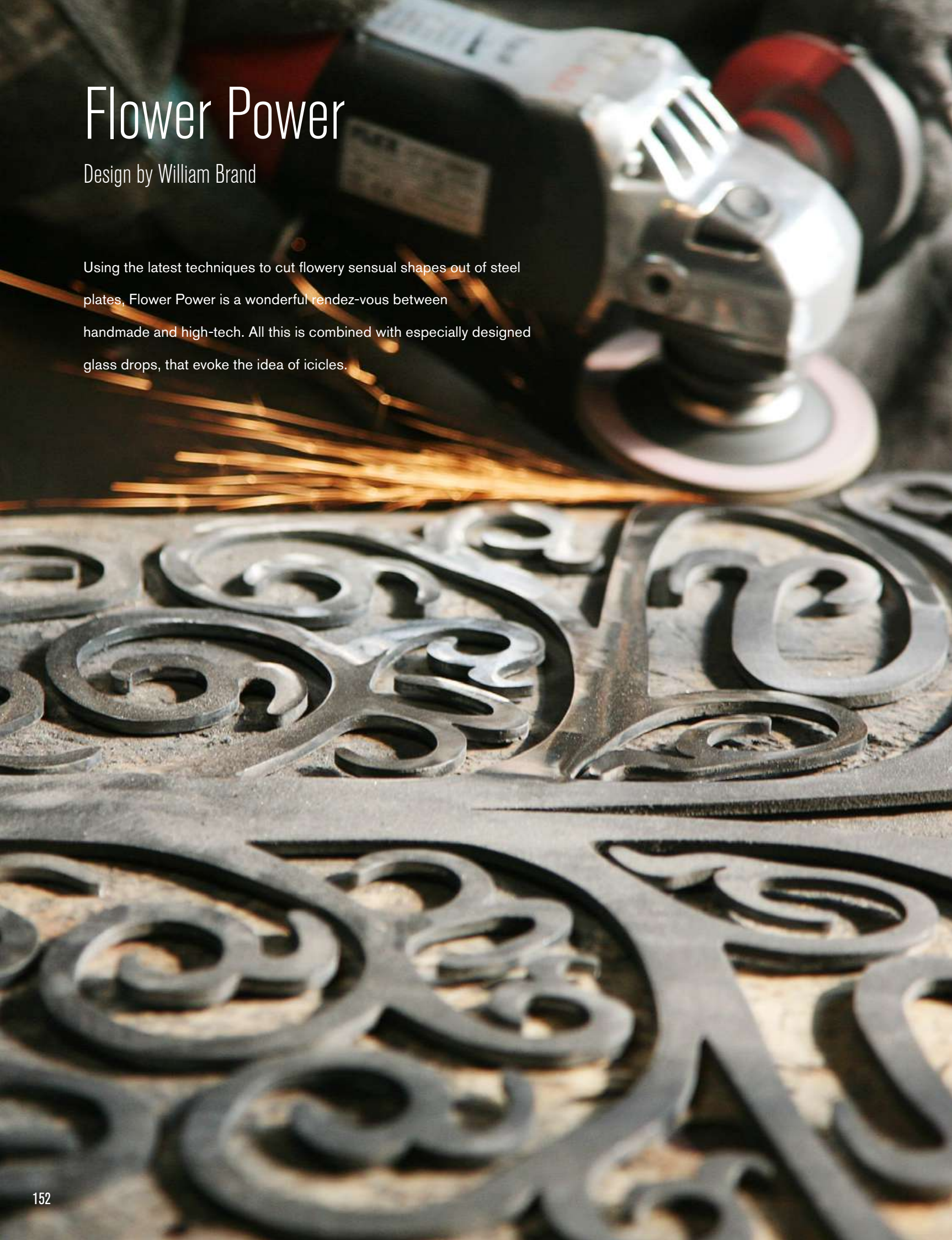



FLOWER POWER CHANDELIER ROUND FPC120N

Technical details page 276



FLOWER POWER CHANDELIER ROUND FPCUSD80W

Technical details page 276



RESTAURANT POSTHOORN MONNICKENDAM, NL FEATURING FLOWER POWER CHANDELIER OVAL FPH0135BL

Technical details page 277



FLOWER POWER CHANDELIER OVAL FPH0135N

Technical details page 277



FLOWER POWER CEILING LAMP FPP80BL

Technical details page 278



FLOWER POWER WALL LAMP FPW30N-R

Technical details page 278

Icy Lady

Design by William Brand

When creating we close our eyes, in order to see. Combining the best materials and techniques to create objects that can be admired both from afar and up close. An elegant and ladylike posture combined with sparkling crystals results in the collection Icy Lady.





KONINGSKINDEREN DAY CARE NAARDEN, NL FEATURING ICY LADY CHANDELIER ROUND ILC120W

Technical details page 279

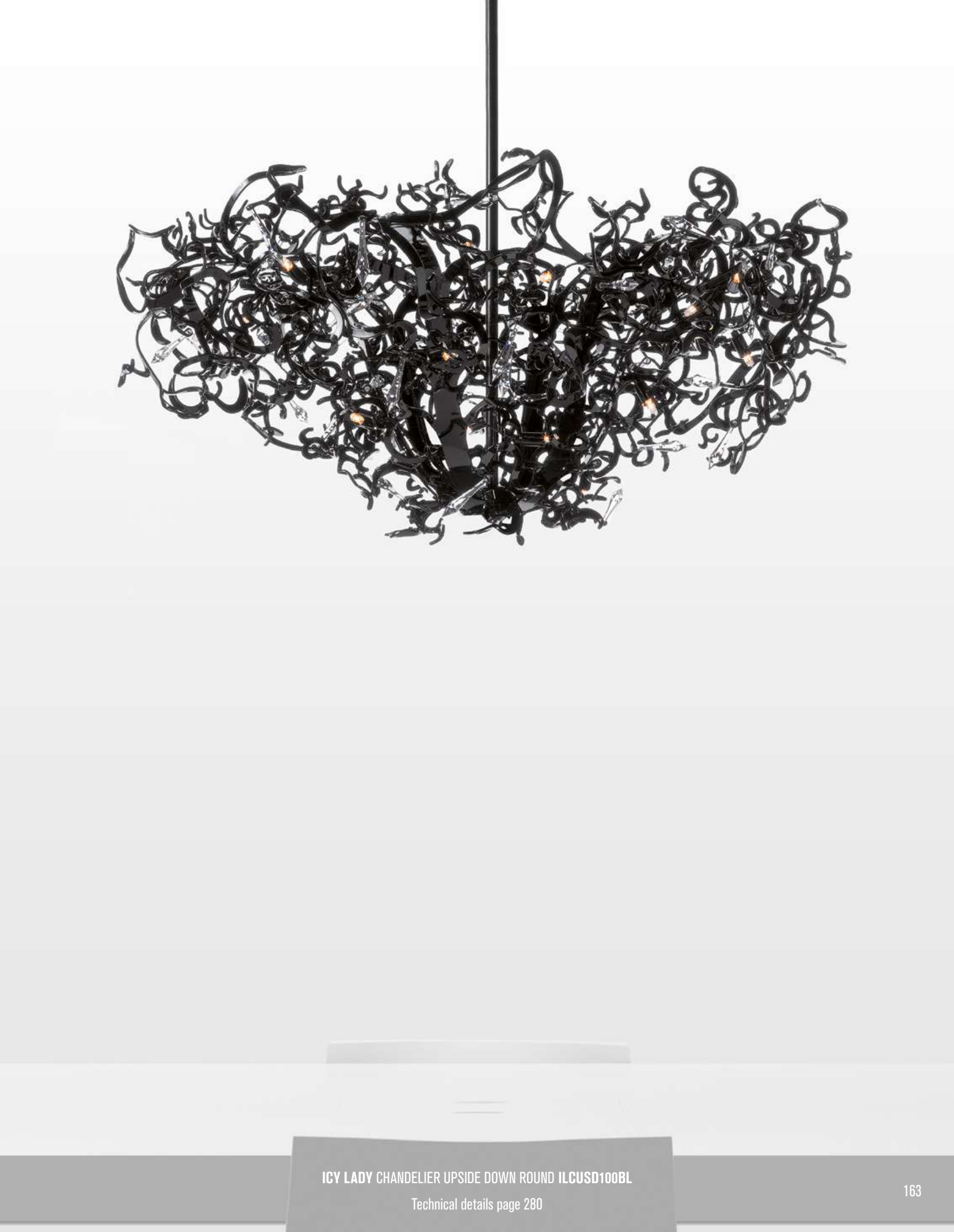

ICY LADY CHANDELIER UPSIDE DOWN ROUND ILCUSD100BL

Technical details page 280



VAN DER VALK, IAM AMSTERDAM HOTEL AMSTERDAM, NL FEATURING ICY LADY CHANDELIER CUSTOMISED

Ø 150 CM, H 150 CM, GOLD LEAF



ICY LADY WALL LAMP ILW30N-R

Technical details page 280



ICY LADY CEILING LAMP ILP60N
Technical details page 281



ICY LADY CEILING LAMP ILP80W
Technical details page 281

Broom

Design by William Brand

Bowing gently in the wind, yet remaining fundamentally untouched by the forces that surround us, Broom echoes the importance of agility in life.

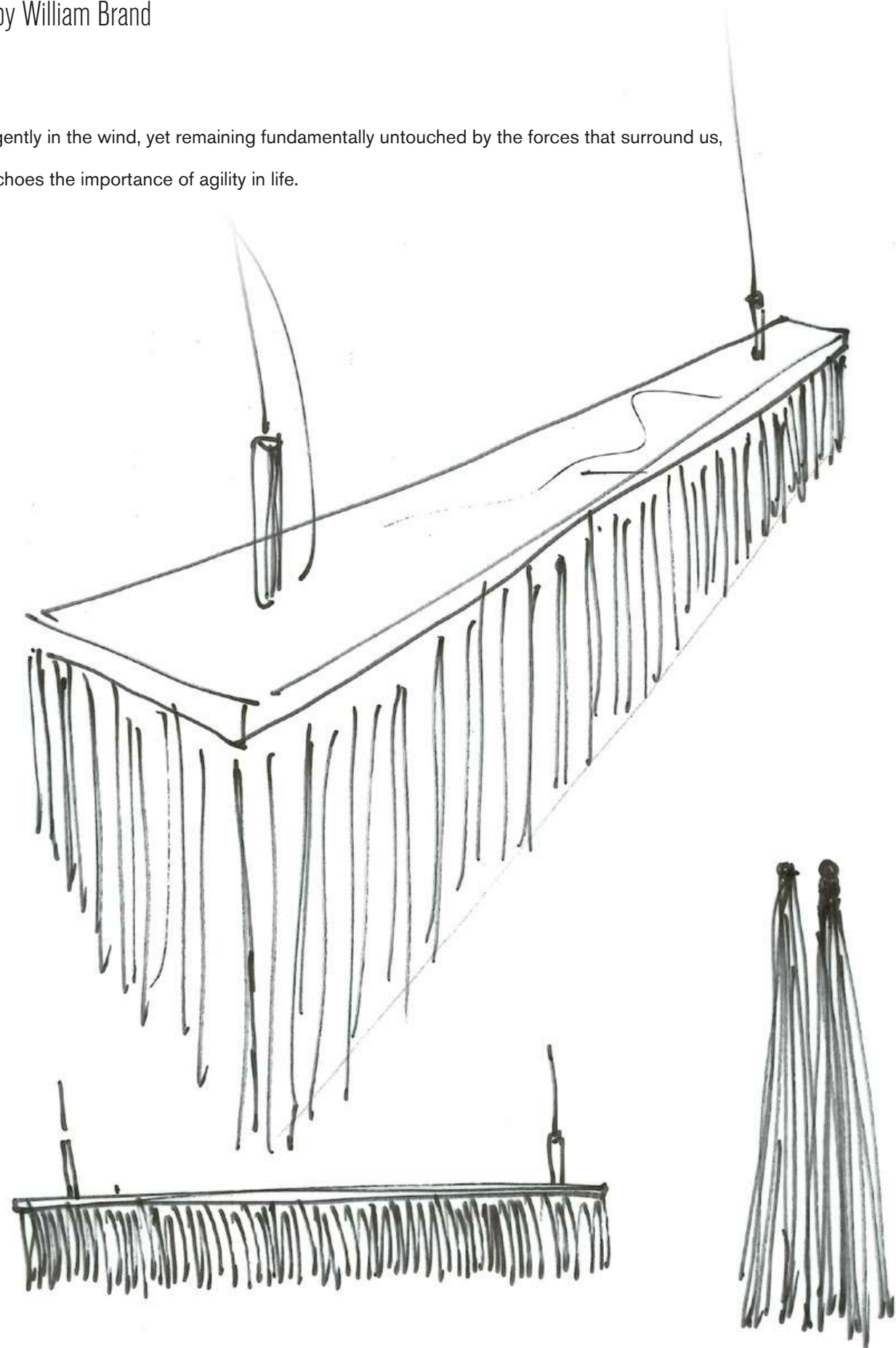



BROOM WALL LAMP BW13ST
Technical details page 282



BROOM FLOOR LAMP BF195ST
Technical details page 282





Rhapsody in Blue

Design by William Brand

A wilderness of energy and vibrant life, trapped in a framework of straight architectural lines, bursting to branch out; an artistic expression and simultaneously a homage to Gershwin's composition echoing city life and sounds. Art is an attempt to bring order into chaos.





RHAPSODY IN BLUE HANGING LAMP LONG RH200ST
Technical details page 283



LOUIS VUITTON, MACY'S, NEW YORK, US FEATURING RHAPSODY IN BLUE HANGING LAMP CUSTOMISED
LENGTH 200 CM, WIDTH 70 CM, HEIGHT 30 CM, STAINLESS STEEL

Crystal Waters

Design by William Brand

Allowing the fine wiry parts to find their own way, like water leaving a riverbed, a wide range of shapes and dimensions flow smoothly from the collection of Crystal Waters. Eventually, all things merge into one, and a river runs through it...





CRYSTAL WATERS SUSPENSION LAMP CWS200NH

Technical details page 285



CRYSTAL WATERS CHANDELIER SHADE CWSHADE60NH

Technical details page 285



PRIVATE INTERIOR THE HAGUE, NL FEATURING CRYSTAL WATERS CHANDELIER HOOD CWS105NH

A project by Damad Lichtstudio - Technical details page 284



CRYSTAL WATERS HANGING LAMP CWH60NH

Technical details page 284



COSMOPOLITAN HOTEL, VIOLET HOUR LAS VEGAS, US FEATURING CRYSTAL WATERS HANGING LAMP "UFO" CWH80NH

Technical details page 284



CRYSTAL WATERS CEILING LAMP CWP120NH, CWP100NH, CWP80NH, CWP60NH, CWP40NH

Technical details page 286



PRIVATE INTERIOR THE HAGUE, NL FEATURING CRYSTAL WATERS WALL LAMP 150CW1N

A project by Damad Lichtstudio - Technical details page 286



CRYSTAL WATERS FLOOR LAMP CWF180NH

Technical details page 286

Allowing the fine wiry parts to find their own way, like water leaving the waterbed, a wide range of shapes and dimensions flow smoothly from the Crystal Waters collection. The Crystal Waters-Drop is easily applied to staircases or spaces with high ceilings.



CRYSTAL WATERS-DROP CWH130NH

Technical details page 285



CRYSTAL WATERS-DROP CWH130NH

CRYSTAL WATERS-DROP CWH160NH

CRYSTAL WATERS-DROP CWH200NH

Technical details page 285

Delphinium

Design by William Brand

It is a small step from the purity of nature to the pleasures of life, a step taken at the time of the introduction of Delphinium.

The structure of frivolous iron garlands carrying glass elements evokes an almost secret longing for times bygone.

A new stream of dancing designs comes to the fore, all with a playful hint of hedonism.



DELPHINIUM CHANDELIER CONICAL DCC70N

Technical details page 287





PRIVATE INTERIOR KITZBÜHEL, AT FEATURING DELPHINIUM CHANDELIER ROUND DC140N. INTERIOR DESIGN BY SPLENDID ARCHITECTURE GBR

Technical details page 287

PAUL NOYEN AMSTERDAM, NL FEATURING DELPHINIUM CHANDELIER ROUND DC100N

Technical details page 287



PRIVATE BANK AMSTERDAM, NL FEATURING DELPHINIUM CHANDELIER ROUND DC120N

Technical details page 287



DELPHINIUM CEILING LAMP DP80N

Technical details page 288



DELPHINIUM WALL LAMP DW20N-R AND DW35N

Technical details page 288



DELPHINIUM TABLE LAMP DT40ST

Technical details page 288

Hollywood

Design by William Brand

Travelling through Africa, William and Annet were touched by the slenderness and pure beauty of the branches and trees scattered across the land. Just as nature comes in all forms and shapes the Hollywood line is equally diverse, including round, conical and square shapes.

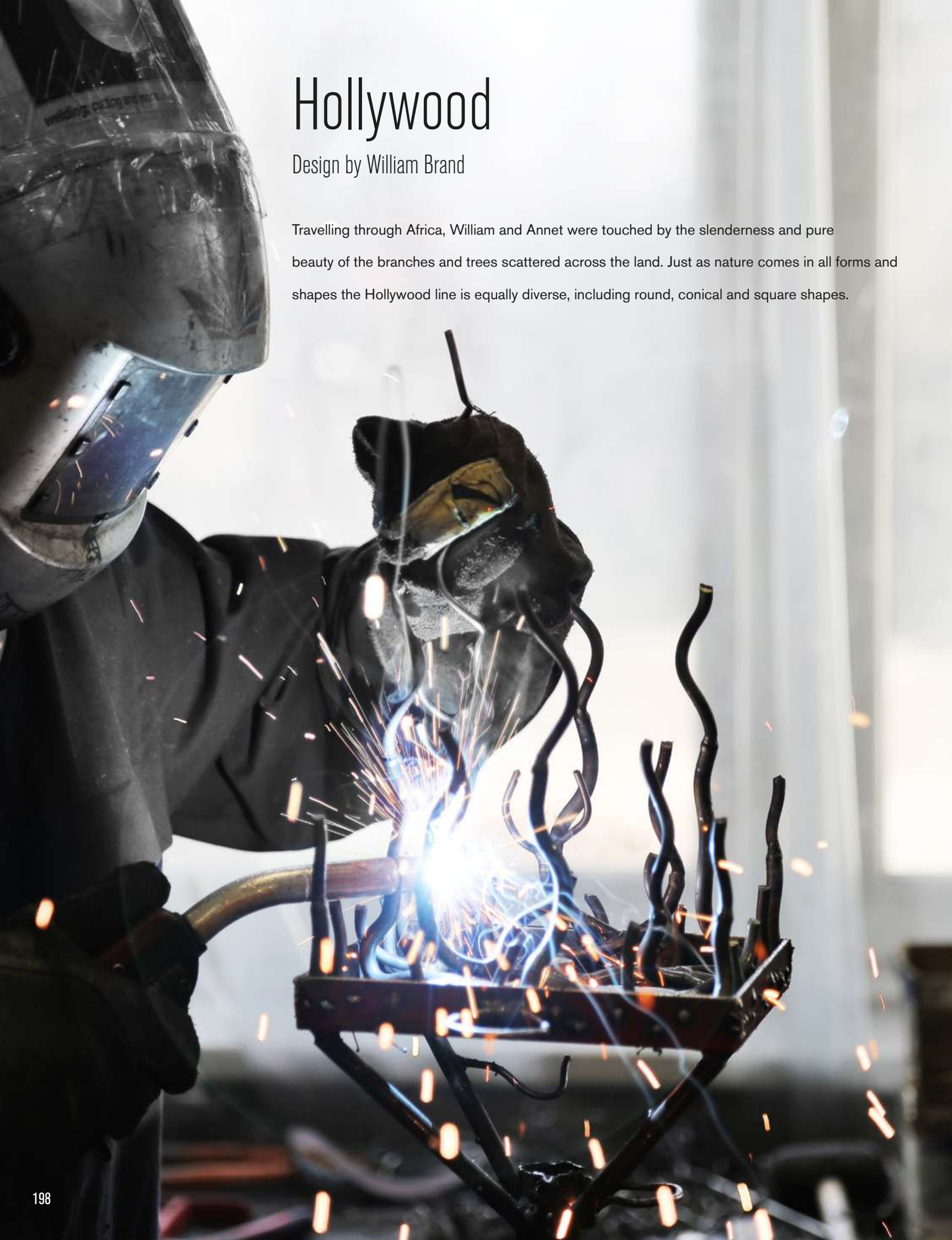



HOLLYWOOD CHANDELIER CONICAL HCC90N - ANY SIZE AS CUSTOMISED OBJECT POSSIBLE

Technical details page 291



TER WERVE RIJSWIJK, NL FEATURING HOLLYWOOD CHANDELIER CONICAL HCC90W

Technical details page 291



HOLLYWOOD CHANDELIER CONICAL OVAL HCCO140N

Technical details page 292



HOLLYWOOD CHANDELIER CONICAL OVAL HCCO140N

Technical details page 292



HOLLYWOOD CEILING CHANDELIER HPH80N

Technical details page 292



THE CAPE PHUKET, TH, BY PHILIP STARCK EN JEAN-MICHEL GATHY THROUGH GECO FEATURING HOLLYWOOD CANDLESTICK ROUND HCCH10X10N

Technical details page 290



HOLLYWOOD CHANDELIER OVAL HOC70N
Technical details page 291



HOLLYWOOD CHANDELIER ROUND HC120N
Technical details page 290







HOLLYWOOD HANGING LAMP IN LINE HH25N-4IL

Technical details page 289



HOLLYWOOD HANGING LAMP HH25N

Technical details page 289





HOLLYWOOD hanging lamp long **HHL100N**
Technical details page 289



HOLLYWOOD HANGING LAMP LONG CUSTOMISED **SPHHL225N**
Length 225 cm, Width 30 cm, Height 40 cm, 7x E27, nickel finish



HOLLYWOOD CEILING LAMP HP80N
Technical details page 293



HOLLYWOOD WALL LAMP HW30N-L AND WALL LAMP BLOCK HW45N
Technical details page 293



HOOGHE VUURSICHE BAARN, NL FEATURING HOLLYWOOD TABLE LAMP HT55N, WALL LAMP BLOCK HW45N AND FLOOR LAMP HF170N

Technical details page 293 and 294



HOLLYWOOD TABLE LAMP HT70N

Technical details page 294



HOLLYWOOD FLOOR LAMP HF170W
Technical details page 294



HOLLYWOOD FLOOR LAMP HF190N AND HF170N
Technical details page 294

Hollywood Glass

Design by William Brand

The Hollywood collection doesn't just come in all forms and shapes, but can also be combined with glass icicles.
Adding them brings extra character and strength at the very same time.



HOLLYWOOD GLASS CHANDELIER CONICAL HCCGL100N

Technical details page 295





CUSTOMISED HOLLYWOOD GLASS H180XØ100CM WITH HOLLOW ICICLES.
NICKEL FINISH



CUSTOMISED HOLLYWOOD GLASS H180XØ100CM WITH HOLLOW ICICLES.
NICKEL FINISH





HOLLYWOOD GLASS CEILING LAMP HPGL120N

Technical details page 296



HOLLYWOOD GLASS CEILING LAMP HPGL40N

Technical details page 296



HOLLYWOOD GLASS CEILING LAMP HPGLH80N

Technical details page 296

Optional finishes



008

Bronze



013

Copper high gloss



017

Nickel aged



012

Brass aged



017

Brass grinded



010

Brass high gloss



011

Brass matt



004

White matt



002

Black matt

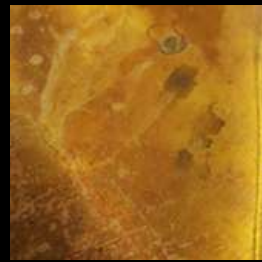

SPECIAL

Burnished brass



Architects and other co-creatives are invited to discover the endless possibilities of customising our lighting sculptures. We hope to inspire you through the different colours and forms of various compositions, just as we enjoy being stimulated by your requests. William Brand's background in architecture gives him the insight to fully understand the demands and challenges of your work. Combined with his experience he is the perfect partner to translate your needs into handcrafted reality.

For our clients we not only customise to different dimensions, but also to different finishes: allowing a truly personal lighting sculpture to be created.

A new finish applicable to several collections is brass grinded.

The possibilities with our lighting sculptures are, in fact, limitless.

We would like to show some of the new possibilities.

CUSTOMISED HOLLYWOOD GLASS H100XØ80CM, 12 X E14, 33KG.

VACUUM METALLISATION GOLD FINISH

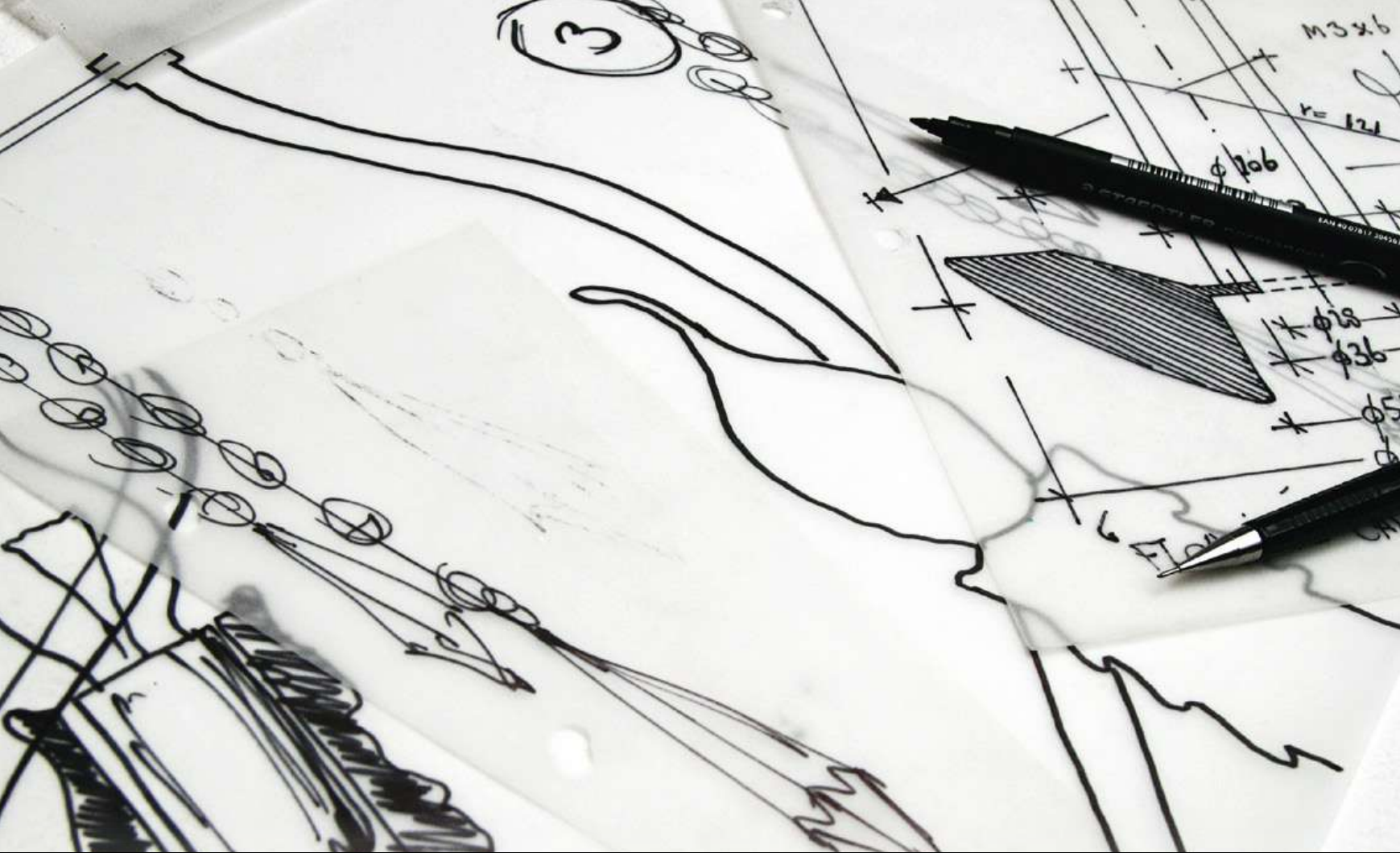

William Brand

designer / owner

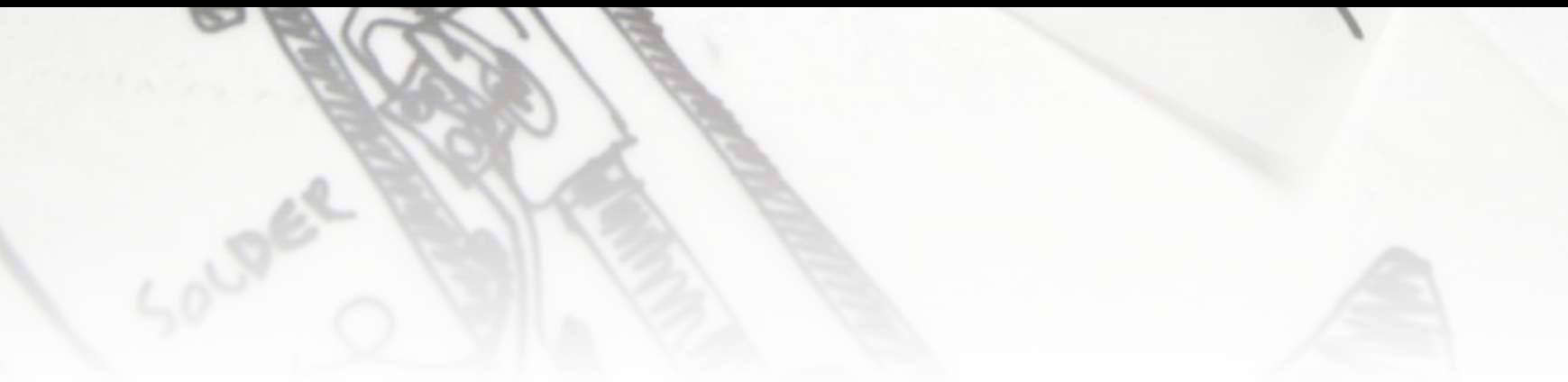

William was trained as an artist and an architect. He graduated at the Utrecht School of Arts.

As an award-winning furniture designer he for many years designed buildings and interiors for fashion brands, including the headquarters of BRAND VAN EGMOND. His interior designs are always minimalist, in contrast to his lighting designs which have a powerful sculptural presence. He considers his lighting objects to be "the cherry on the cake". His way of working is quite specific. Immediately after defining the concept he starts working in the workshop like a sculptor; experimenting and crafting while having the object grow in his hands, often with unexpected results. Therefore the journey is just as exciting and important as the destination.



Certificate



Each BRAND VAN EGMOND lighting sculpture is issued with a certificate of authenticity and registered with a unique number. This guarantees that you are in possession of an original BRAND VAN EGMOND object.

We advise you to keep this certificate together with your receipt of purchase in a safe place.

Technical information



Collection Eve 2016

Chandelier Conical

| Art.nr. | Dimensions CM |
|------------|--|
| EVECC60BLM | Ø 60cm, Height 70cm, Length chain 170cm, 10x E14, 14,0 kg, black matt finish |
| EVECC60WM | Ø 60cm, Height 70cm, Length chain 170cm, 10x E14, 14,0 kg, white matt finish |
| EVECC60B | Ø 60cm, Height 70cm, Length chain 170cm, 10x E14, 14,0 kg, bronze finish |
| EVECC60N | Ø 60cm, Height 70cm, Length chain 170cm, 10x E14, 14,0 kg, nickel finish |
| EVECC60COP | Ø 60cm, Height 70cm, Length chain 170cm, 10x E14, 14,0 kg, copper finish |
| EVECC60BR | Ø 60cm, Height 70cm, Length chain 170cm, 10x E14, 14,0 kg, brass finish |
| EVECC70BLM | Ø 70cm, Height 80cm, Length chain 170cm, 12x E14, 16,0 kg, black matt finish |
| EVECC70WM | Ø 70cm, Height 80cm, Length chain 170cm, 12x E14, 16,0 kg, white matt finish |
| EVECC70B | Ø 70cm, Height 80cm, Length chain 170cm, 12x E14, 16,0 kg, bronze finish |
| EVECC70N | Ø 70cm, Height 80cm, Length chain 170cm, 12x E14, 16,0 kg, nickel finish |
| EVECC70COP | Ø 70cm, Height 80cm, Length chain 170cm, 12x E14, 16,0 kg, copper finish |
| EVECC70BR | Ø 70cm, Height 80cm, Length chain 170cm, 12x E14, 16,0 kg, brass finish |
| EVECC80BLM | Ø 80cm, Height 90cm, Length chain 170cm, 12x E14, 18,0 kg, black matt finish |
| EVECC80WM | Ø 80cm, Height 90cm, Length chain 170cm, 12x E14, 18,0 kg, white matt finish |
| EVECC80B | Ø 80cm, Height 90cm, Length chain 170cm, 12x E14, 18,0 kg, bronze finish |
| EVECC80N | Ø 80cm, Height 90cm, Length chain 170cm, 12x E14, 18,0 kg, nickel finish |
| EVECC80COP | Ø 80cm, Height 90cm, Length chain 170cm, 12x E14, 18,0 kg, copper finish |
| EVECC80BR | Ø 80cm, Height 90cm, Length chain 170cm, 12x E14, 18,0 kg, brass finish |

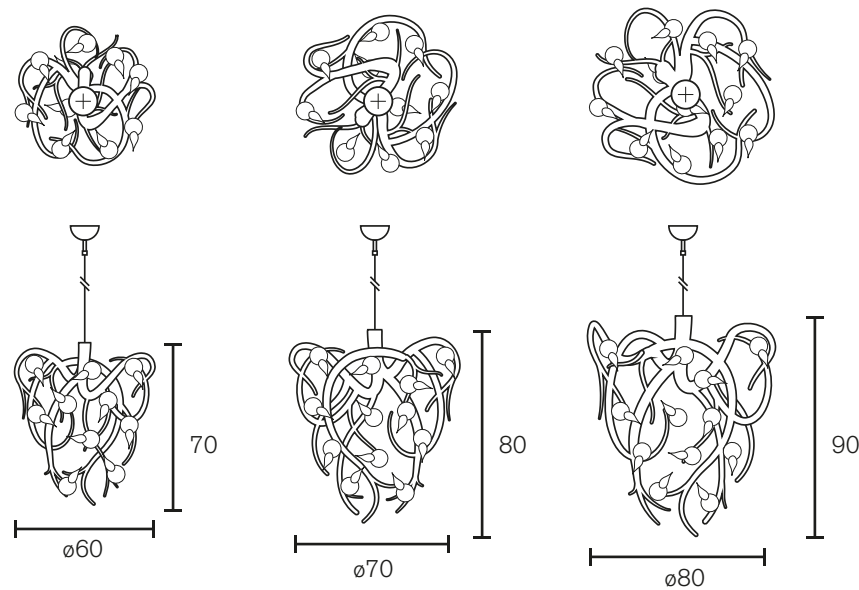

All chandeliers are supplied with 1,7 meter chain, 2 meter electrical cable and a ceiling shade. All floor- and table lamps are supplied with a dimmer.

Chandelier Oval

| Art.nr. | Dimensions CM |
|-------------|--|
| EVEOC120BLM | Length 120cm, Width 60cm, Height 60cm, Length chain 170cm, 10x E14, 14,0 kg, black matt finish |
| EVEOC120WM | Length 120cm, Width 60cm, Height 60cm, Length chain 170cm, 10x E14, 14,0 kg, white matt finish |
| EVEOC120B | Length 120cm, Width 60cm, Height 60cm, Length chain 170cm, 10x E14, 14,0 kg, bronze finish |
| EVEOC120N | Length 120cm, Width 60cm, Height 60cm, Length chain 170cm, 10x E14, 14,0 kg, nickel finish |
| EVEOC120COP | Length 120cm, Width 60cm, Height 60cm, Length chain 170cm, 10x E14, 14,0 kg, copper finish |
| EVEOC120BR | Length 120cm, Width 60cm, Height 60cm, Length chain 170cm, 10x E14, 14,0 kg, brass finish |
| EVEOC140BLM | Length 140cm, Width 60cm, Height 60cm, Length chain 170cm, 12x E14, 16,0 kg, black matt finish |
| EVEOC140WM | Length 140cm, Width 60cm, Height 60cm, Length chain 170cm, 12x E14, 16,0 kg, white matt finish |
| EVEOC140B | Length 140cm, Width 60cm, Height 60cm, Length chain 170cm, 12x E14, 16,0 kg, bronze finish |
| EVEOC140N | Length 140cm, Width 60cm, Height 60cm, Length chain 170cm, 12x E14, 16,0 kg, nickel finish |
| EVEOC140COP | Length 140cm, Width 60cm, Height 60cm, Length chain 170cm, 12x E14, 16,0 kg, copper finish |
| EVEOC140BR | Length 140cm, Width 60cm, Height 60cm, Length chain 170cm, 12x E14, 16,0 kg, brass finish |
| EVEOC160BLM | Length 160cm, Width 60cm, Height 60cm, Length chain 170cm, 12x E14, 18,0 kg, black matt finish |
| EVEOC160WM | Length 160cm, Width 60cm, Height 60cm, Length chain 170cm, 12x E14, 18,0 kg, white matt finish |
| EVEOC160B | Length 160cm, Width 60cm, Height 60cm, Length chain 170cm, 12x E14, 18,0 kg, bronze finish |
| EVEOC160N | Length 160cm, Width 60cm, Height 60cm, Length chain 170cm, 12x E14, 18,0 kg, nickel finish |
| EVEOC160COP | Length 160cm, Width 60cm, Height 60cm, Length chain 170cm, 12x E14, 18,0 kg, copper finish |
| EVEOC160BR | Length 160cm, Width 60cm, Height 60cm, Length chain 170cm, 12x E14, 18,0 kg, brass finish |

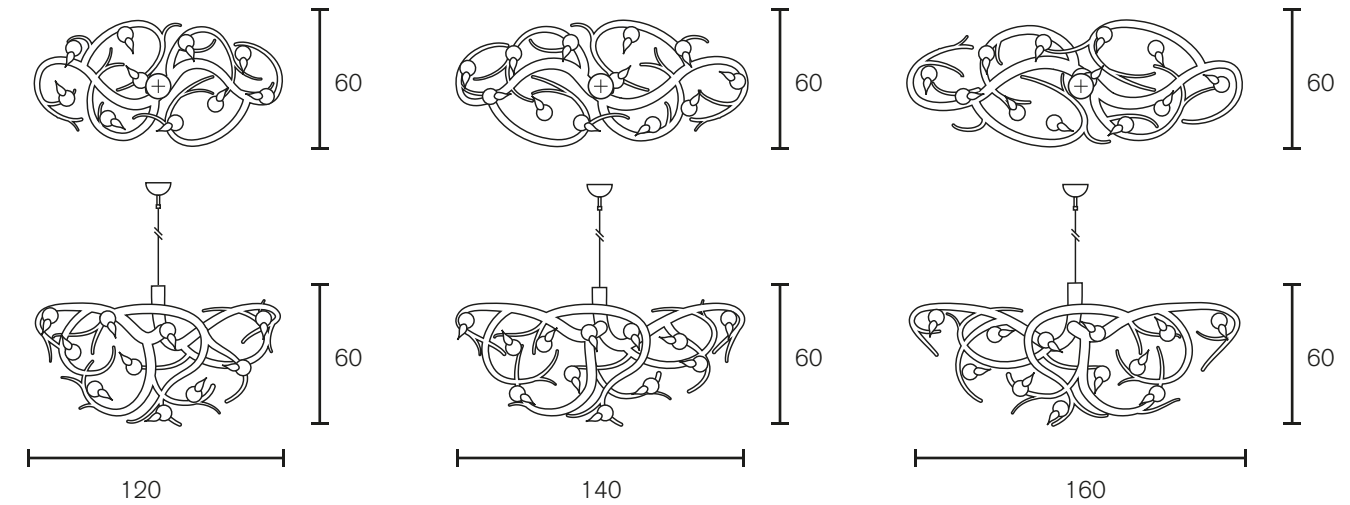

All chandeliers are supplied with 1,7 meter chain, 2 meter electrical cable and a ceiling shade. All floor- and table lamps are supplied with a dimmer.

Chandelier Round

| Art.nr. | Dimensions CM |
|------------|---|
| EVEC80BLM | Ø 80cm, Height 60cm, Length chain 170cm, 12x E14, 11,0 kg, black matt finish |
| EVEC80WM | Ø 80cm, Height 60cm, Length chain 170cm, 12x E14, 11,0 kg, white matt finish |
| EVEC80B | Ø 80cm, Height 60cm, Length chain 170cm, 12x E14, 11,0 kg, bronze finish |
| EVEC80N | Ø 80cm, Height 60cm, Length chain 170cm, 12x E14, 11,0 kg, nickel finish |
| EVEC80COP | Ø 80cm, Height 60cm, Length chain 170cm, 12x E14, 11,0 kg, copper finish |
| EVEC80BR | Ø 80cm, Height 60cm, Length chain 170cm, 12x E14, 11,0 kg, brass finish |
| EVEC100BLM | Ø 100cm, Height 60cm, Length chain 170cm, 14x E14, 13,0 kg, black matt finish |
| EVEC100WM | Ø 100cm, Height 60cm, Length chain 170cm, 14x E14, 13,0 kg, white matt finish |
| EVEC100B | Ø 100cm, Height 60cm, Length chain 170cm, 14x E14, 13,0 kg, bronze finish |
| EVEC100N | Ø 100cm, Height 60cm, Length chain 170cm, 14x E14, 13,0 kg, nickel finish |
| EVEC100COP | Ø 100cm, Height 60cm, Length chain 170cm, 14x E14, 13,0 kg, copper finish |
| EVEC100BR | Ø 100cm, Height 60cm, Length chain 170cm, 14x E14, 13,0 kg, brass finish |
| EVEC120BLM | Ø 120cm, Height 60cm, Length chain 170cm, 14x E14, 15,0 kg, black matt finish |
| EVEC120WM | Ø 120cm, Height 60cm, Length chain 170cm, 14x E14, 15,0 kg, white matt finish |
| EVEC120B | Ø 120cm, Height 60cm, Length chain 170cm, 14x E14, 15,0 kg, bronze finish |
| EVEC120N | Ø 120cm, Height 60cm, Length chain 170cm, 14x E14, 15,0 kg, nickel finish |
| EVEC120COP | Ø 120cm, Height 60cm, Length chain 170cm, 14x E14, 15,0 kg, copper finish |
| EVEC120BR | Ø 120cm, Height 60cm, Length chain 170cm, 14x E14, 15,0 kg, brass finish |

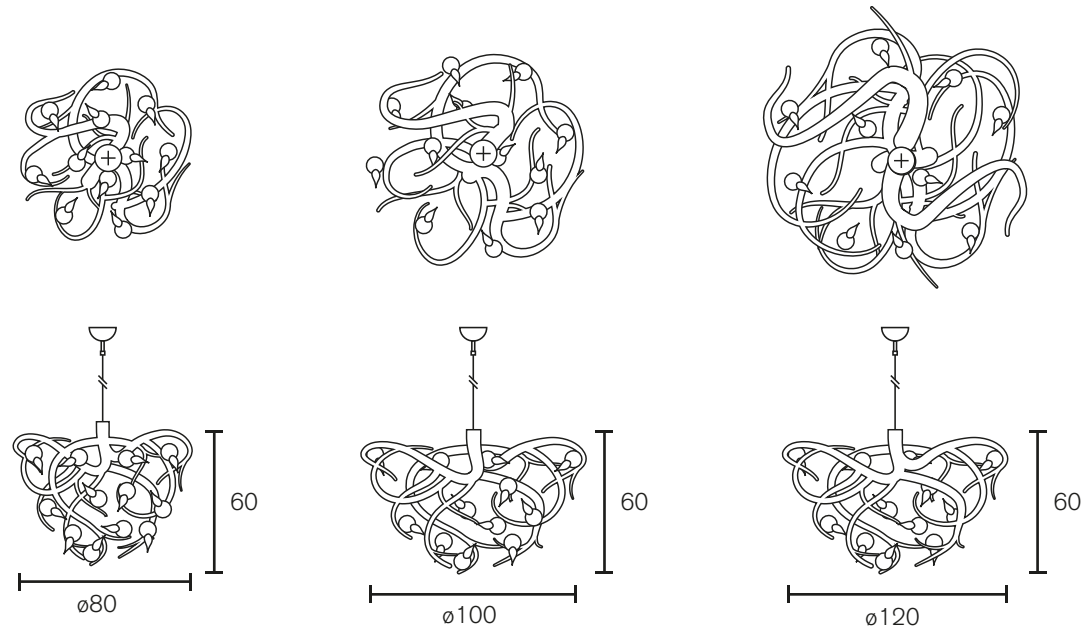

All chandeliers are supplied with 1,7 meter chain, 2 meter electrical cable and a ceiling shade. All floor- and table lamps are supplied with a dimmer.

Collection Fractal 2015

Chandelier Round

| Art.nr. | Dimensions CM |
|-------------|--|
| FRACC80BLM | Ø 80cm, Height 35cm, Length steel cable 200cm, 10x E14, 19,0 kg, black matt finish |
| FRACC80WM | Ø 80cm, Height 35cm, Length steel cable 200cm, 10x E14, 19,0 kg, white matt finish |
| FRACC80ST | Ø 80cm, Height 35cm, Length steel cable 200cm, 10x E14, 19,0 kg, stainless steel |
| FRACC80COP | Ø 80cm, Height 35cm, Length steel cable 200cm, 8x E14, 19,0 kg, copper finish |
| FRACC80BR | Ø 80cm, Height 35cm, Length steel cable 200cm, 8x E14, 19,0 kg, brass finish |
| FRACC80BRG | Ø 80cm, Height 35cm, Length steel cable 200cm, 8x E14, 19,0 kg, brass grinded finish |
| FRACC100BLM | Ø 100cm, Height 45cm, Length steel cable 200cm, 12x E14, 27,0 kg, black matt finish |
| FRACC100WM | Ø 100cm, Height 45cm, Length steel cable 200cm, 12x E14, 27,0 kg, white matt finish |
| FRACC100ST | Ø 100cm, Height 45cm, Length steel cable 200cm, 12x E14, 27,0 kg, stainless steel |
| FRACC100COP | Ø 100cm, Height 45cm, Length steel cable 200cm, 12x E14, 27,0 kg, copper finish |
| FRACC100BR | Ø 100cm, Height 45cm, Length steel cable 200cm, 12x E14, 27,0 kg, brass finish |
| FRACC100BRG | Ø 100cm, Height 45cm, Length steel cable 200cm, 12x E14, 27,0 kg, brass grinded finish |

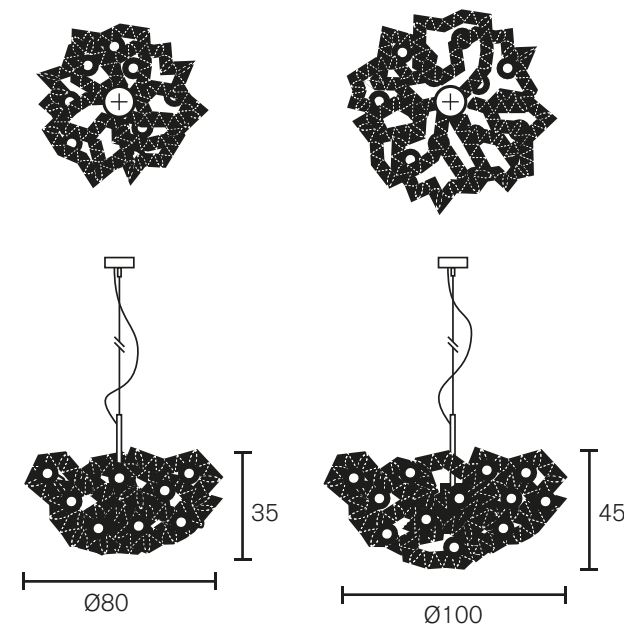

All hanging lamps are supplied with 2 meter electrical cable, 2 meter steel cable and a ceiling shade.

Collection Fractal Cloud 2015

Hanging Lamp Cloud

| Art.nr. | Dimensions CM |
|-------------|--|
| FRACHR55BLM | Ø 55cm, Height 60cm, Length steel cable 200cm, 3x E27, 13,0 kg, black matt finish |
| FRACHR55WM | Ø 55cm, Height 60cm, Length steel cable 200cm, 3x E27, 13,0 kg, white matt finish |
| FRACHR55ST | Ø 55cm, Height 60cm, Length steel cable 200cm, 3x E27, 13,0 kg, stainless steel |
| FRACHR55COP | Ø 55cm, Height 60cm, Length steel cable 200cm, 3x E27, 13,0 kg, copper finish |
| FRACHR55BR | Ø 55cm, Height 60cm, Length steel cable 200cm, 3x E27, 13,0 kg, brass finish |
| FRACHR55BRG | Ø 55cm, Height 60cm, Length steel cable 200cm, 3x E27, 13,0 kg, brass grinded finish |
| FRACHR70BLM | Ø 70cm, Height 75cm, Length steel cable 200cm, 3x E27, 18,0 kg, black matt finish |
| FRACHR70WM | Ø 70cm, Height 75cm, Length steel cable 200cm, 3x E27, 18,0 kg, white matt finish |
| FRACHR70ST | Ø 70cm, Height 75cm, Length steel cable 200cm, 3x E27, 18,0 kg, stainless steel |
| FRACHR70COP | Ø 70cm, Height 75cm, Length steel cable 200cm, 3x E27, 18,0 kg, copper finish |
| FRACHR70BR | Ø 70cm, Height 75cm, Length steel cable 200cm, 3x E27, 18,0 kg, brass finish |
| FRACHR70BRG | Ø 70cm, Height 75cm, Length steel cable 200cm, 3x E27, 18,0 kg, brass grinded finish |

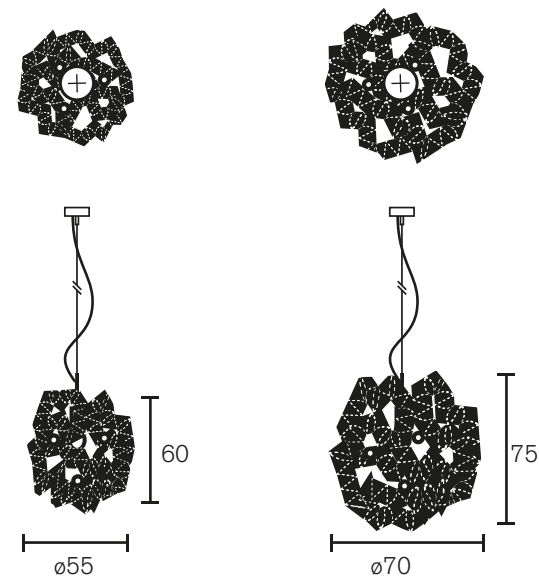

Fractal hanging lamp "cloud" due to the production reasons dimension might vary a couple of centimeters in all directions

Collection Flintstone 2015

Floor lamp

| Art.nr. | Dimensions CM |
|--------------|--|
| FLINTF70BLM | Length 70cm, Width 40cm, Height 235cm, 1x E27, 40,0 kg, black matt finish |
| FLINTF70WM | Length 70cm, Width 40cm, Height 235cm, 1x E27, 40,0 kg, white matt finish |
| FLINTF70N | Length 70cm, Width 40cm, Height 235cm, 1x E27, 40,0 kg, nickel finish |
| FLINTF100BLM | Length 100cm, Width 40cm, Height 235cm, 1x E27, 40,0 kg, black matt finish |
| FLINTF100WM | Length 100cm, Width 40cm, Height 235cm, 1x E27, 40,0 kg, white matt finish |
| FLINTF100N | Length 100cm, Width 40cm, Height 235cm, 1x E27, 40,0 kg, nickel finish |
| FLINTF130BLM | Length 130cm, Width 40cm, Height 235cm, 1x E27, 40,0 kg, black matt finish |
| FLINTF130WM | Length 130cm, Width 40cm, Height 235cm, 1x E27, 40,0 kg, white matt finish |
| FLINTF130N | Length 130cm, Width 40cm, Height 235cm, 1x E27, 40,0 kg, nickel finish |
| FLINTF160BLM | Length 160cm, Width 40cm, Height 235cm, 1x E27, 40,0 kg, black matt finish |
| FLINTF160WM | Length 160cm, Width 40cm, Height 235cm, 1x E27, 40,0 kg, white matt finish |
| FLINTF160N | Length 160cm, Width 40cm, Height 235cm, 1x E27, 40,0 kg, nickel finish |
| FLINTF190BLM | Length 190cm, Width 40cm, Height 235cm, 1x E27, 40,0 kg, black matt finish |
| FLINTF190WM | Length 190cm, Width 40cm, Height 235cm, 1x E27, 40,0 kg, white matt finish |
| FLINTF190N | Length 190cm, Width 40cm, Height 235cm, 1x E27, 40,0 kg, nickel finish |
| FLINTF210BLM | Length 210cm, Width 40cm, Height 235cm, 1x E27, 40,0 kg, black matt finish |
| FLINTF210WM | Length 210cm, Width 40cm, Height 235cm, 1x E27, 40,0 kg, white matt finish |
| FLINTF210N | Length 210cm, Width 40cm, Height 235cm, 1x E27, 40,0 kg, nickel finish |
| FLINTF240BLM | Length 240cm, Width 40cm, Height 235cm, 1x E27, 40,0 kg, black matt finish |
| FLINTF240WM | Length 240cm, Width 40cm, Height 235cm, 1x E27, 40,0 kg, white matt finish |
| FLINTF240N | Length 240cm, Width 40cm, Height 235cm, 1x E27, 40,0 kg, nickel finish |

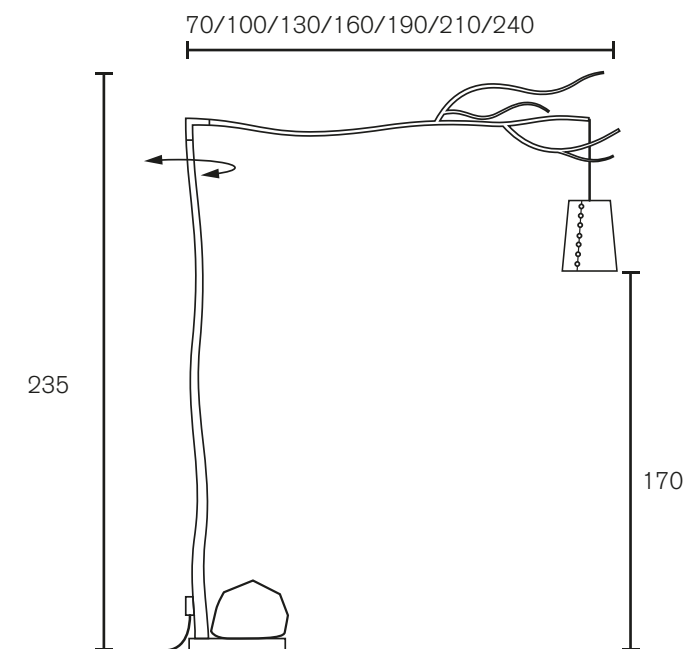

All floor lamps are supplied with a dimmer.
A unique rock will be included with each flintstone by BRAND VAN EGMOND

Collection Kelp 2014

Chandelier Conical

| Art.nr. | Dimensions CM |
|-------------|--|
| KELPCC60BLM | Ø 60cm, Height 70cm, Length stem 200cm, 10x E14, 25,0 kg, black matt finish |
| KELPCC60WM | Ø 60cm, Height 70cm, Length stem 200cm, 10x E14, 25,0 kg, white matt finish |
| KELPCC60B | Ø 60cm, Height 70cm, Length stem 200cm, 10x E14, 25,0 kg, bronze finish |
| KELPCC60ST | Ø 60cm, Height 70cm, Length stem 200cm, 10x E14, 25,0 kg, stainless steel |
| KELPCC60COP | Ø 60cm, Height 70cm, Length stem 200cm, 10x E14, 25,0 kg, copper finish |
| KELPCC60BR | Ø 60cm, Height 70cm, Length stem 200cm, 10x E14, 25,0 kg, brass finish |
| KELPCC60BRA | Ø 60cm, Height 70cm, Length stem 200cm, 10x E14, 25,0 kg, brass aged finish |
| KELPCC60BRG | Ø 60cm, Height 70cm, Length stem 200cm, 10x E14, 25,0 kg, brass grinded finish |
| KELPCC80BLM | Ø 80cm, Height 90cm, Length stem 200cm, 10x E14, 30,0 kg, black matt finish |
| KELPCC80WM | Ø 80cm, Height 90cm, Length stem 200cm, 10x E14, 30,0 kg, white matt finish |
| KELPCC80B | Ø 80cm, Height 90cm, Length stem 200cm, 10x E14, 30,0 kg, bronze finish |
| KELPCC80ST | Ø 80cm, Height 90cm, Length stem 200cm, 10x E14, 30,0 kg, stainless steel |
| KELPCC80COP | Ø 80cm, Height 90cm, Length stem 200cm, 10x E14, 30,0 kg, copper finish |
| KELPCC80BR | Ø 80cm, Height 90cm, Length stem 200cm, 10x E14, 30,0 kg, brass finish |
| KELPCC80BRA | Ø 80cm, Height 90cm, Length stem 200cm, 10x E14, 30,0 kg, brass aged finish |
| KELPCC80BRG | Ø 80cm, Height 90cm, Length stem 200cm, 10x E14, 30,0 kg, brass grinded finish |

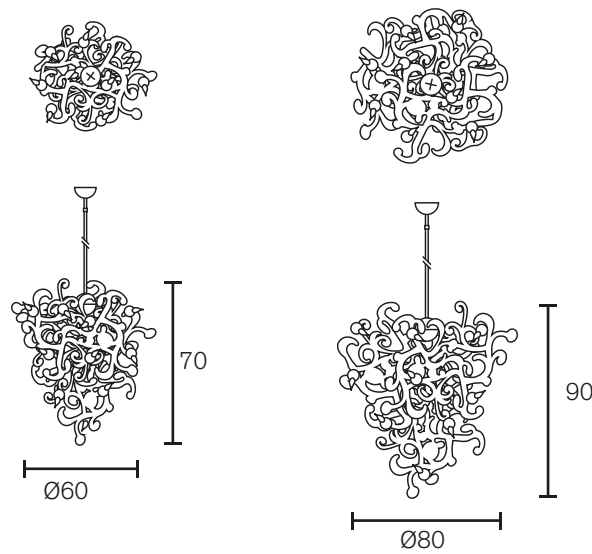

All hanging lamps are supplied with 2 meter electrical cable, 2 meter steel cable and a ceiling shade.
All chandeliers are supplied with 2 meter stem, 2 meter electrical cable and a ceiling shade.

Chandelier Oval

| Art.nr. | Dimensions CM |
|--------------|--|
| KELPOC120BLM | Length 120cm, Width 60cm, Height 55cm, Length stem 200cm, 10x E14, 25,0 kg, black matt finish |
| KELPOC120WM | Length 120cm, Width 60cm, Height 55cm, Length stem 200cm, 10x E14, 25,0 kg, white matt finish |
| KELPOC120B | Length 120cm, Width 60cm, Height 55cm, Length stem 200cm, 10x E14, 25,0 kg, bronze finish |
| KELPOC120ST | Length 120cm, Width 60cm, Height 55cm, Length stem 200cm, 10x E14, 25,0 kg, stainless steel |
| KELPOC120COP | Length 120cm, Width 60cm, Height 55cm, Length stem 200cm, 10x E14, 25,0 kg, copper finish |
| KELPOC120BR | Length 120cm, Width 60cm, Height 55cm, Length stem 200cm, 10x E14, 25,0 kg, brass finish |
| KELPOC120BRA | Length 120cm, Width 60cm, Height 55cm, Length stem 200cm, 10x E14, 25,0 kg, brass aged finish |
| KELPOC120BRG | Length 120cm, Width 60cm, Height 55cm, Length stem 200cm, 10x E14, 25,0 kg, brass grinded finish |
| KELPOC140BLM | Length 140cm, Width 60cm, Height 55cm, Length stem 200cm, 10x E14, 30,0 kg, black matt finish |
| KELPOC140WM | Length 140cm, Width 60cm, Height 55cm, Length stem 200cm, 10x E14, 30,0 kg, white matt finish |
| KELPOC140B | Length 140cm, Width 60cm, Height 55cm, Length stem 200cm, 10x E14, 30,0 kg, bronze finish |
| KELPOC140ST | Length 140cm, Width 60cm, Height 55cm, Length stem 200cm, 10x E14, 30,0 kg, stainless steel |
| KELPOC140COP | Length 140cm, Width 60cm, Height 55cm, Length stem 200cm, 10x E14, 30,0 kg, copper finish |
| KELPOC140BR | Length 140cm, Width 60cm, Height 55cm, Length stem 200cm, 10x E14, 30,0 kg, brass finish |
| KELPOC140BRA | Length 140cm, Width 60cm, Height 55cm, Length stem 200cm, 10x E14, 30,0 kg, brass aged finish |
| KELPOC140BRG | Length 140cm, Width 60cm, Height 55cm, Length stem 200cm, 10x E14, 30,0 kg, brass grinded finish |
| KELPOC160BLM | Length 160cm, Width 60cm, Height 55cm, Length stem 200cm, 10x E14, 40,0 kg, black matt finish |
| KELPOC160WM | Length 160cm, Width 60cm, Height 55cm, Length stem 200cm, 10x E14, 40,0 kg, white matt finish |
| KELPOC160B | Length 160cm, Width 60cm, Height 55cm, Length stem 200cm, 10x E14, 40,0 kg, bronze finish |
| KELPOC160ST | Length 160cm, Width 60cm, Height 55cm, Length stem 200cm, 10x E14, 40,0 kg, stainless steel |
| KELPOC160COP | Length 160cm, Width 60cm, Height 55cm, Length stem 200cm, 10x E14, 40,0 kg, copper finish |
| KELPOC160BR | Length 160cm, Width 60cm, Height 55cm, Length stem 200cm, 10x E14, 40,0 kg, brass finish |
| KELPOC160BRA | Length 160cm, Width 60cm, Height 55cm, Length stem 200cm, 10x E14, 40,0 kg, brass aged finish |
| KELPOC160BRG | Length 160cm, Width 60cm, Height 55cm, Length stem 200cm, 10x E14, 40,0 kg, brass grinded finish |

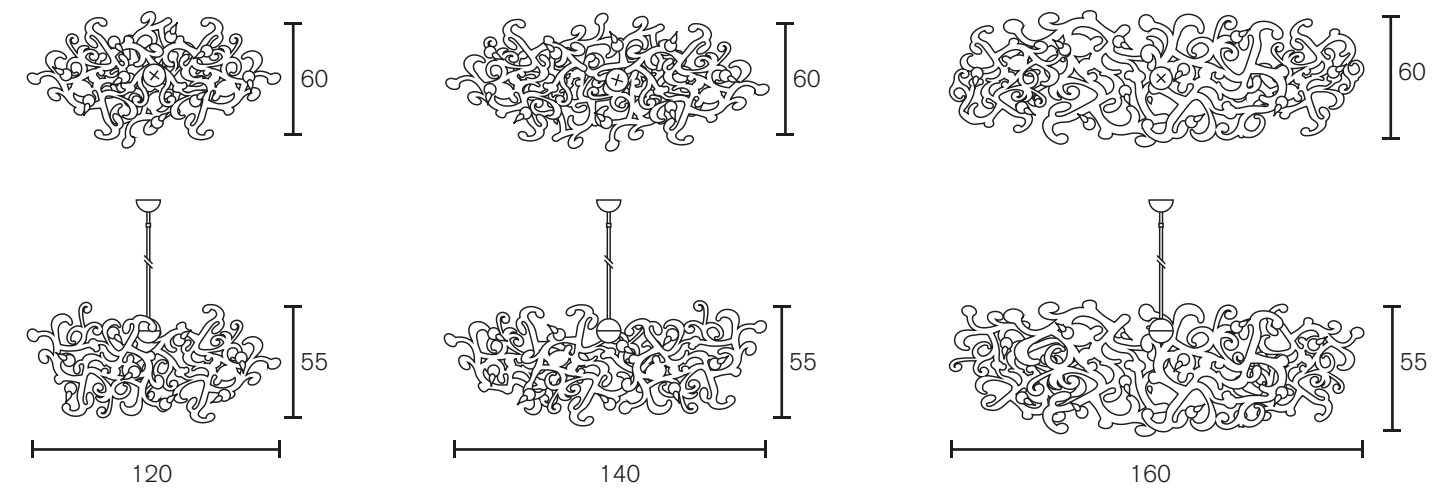

All hanging lamps are supplied with 2 meter electrical cable, 2 meter steel cable and a ceiling shade.
All chandeliers are supplied with 2 meter stem, 2 meter electrical cable and a ceiling shade.

Chandelier Round

| Art.nr. | Dimensions CM |
|-------------|---|
| KELPC80BLM | Ø 80cm, Height 60cm, Length stem 200cm, 10x E14, 25,0 kg, black matt finish |
| KELPC80WM | Ø 80cm, Height 60cm, Length stem 200cm, 10x E14, 25,0 kg, white matt finish |
| KELPC80B | Ø 80cm, Height 60cm, Length stem 200cm, 10x E14, 25,0 kg, bronze finish |
| KELPC80ST | Ø 80cm, Height 60cm, Length stem 200cm, 10x E14, 25,0 kg, stainless steel |
| KELPC80COP | Ø 80cm, Height 60cm, Length stem 200cm, 10x E14, 25,0 kg, copper finish |
| KELPC80BR | Ø 80cm, Height 60cm, Length stem 200cm, 10x E14, 25,0 kg, messing finish |
| KELPC80BRA | Ø 80cm, Height 60cm, Length stem 200cm, 10x E14, 25,0 kg, brass aged finish |
| KELPC80BRG | Ø 80cm, Height 60cm, Length stem 200cm, 10x E14, 25,0 kg, brass grinded finish |
| KELPC100BLM | Ø 100cm, Height 60cm, Length stem 200cm, 10x E14, 40,0 kg, black matt finish |
| KELPC100WM | Ø 100cm, Height 60cm, Length stem 200cm, 10x E14, 40,0 kg, white matt finish |
| KELPC100B | Ø 100cm, Height 60cm, Length stem 200cm, 10x E14, 30,0 kg, bronze finish |
| KELPC100ST | Ø 100cm, Height 60cm, Length stem 200cm, 10x E14, 40,0 kg, stainless steel |
| KELPC100COP | Ø 100cm, Height 60cm, Length stem 200cm, 10x E14, 40,0 kg, copper finish |
| KELPC100BR | Ø 100cm, Height 60cm, Length stem 200cm, 10x E14, 40,0 kg, brass finish |
| KELPC100BRA | Ø 100cm, Height 60cm, Length stem 200cm, 10x E14, 30,0 kg, brass aged finish |
| KELPC100BRG | Ø 100cm, Height 60cm, Length stem 200cm, 10x E14, 30,0 kg, brass grinded finish |
| KELPC120BLM | Ø 120cm, Height 60cm, Length stem 200cm, 10x E14, 30,0 kg, black matt finish |
| KELPC120WM | Ø 120cm, Height 60cm, Length stem 200cm, 10x E14, 30,0 kg, white matt finish |
| KELPC120B | Ø 120cm, Height 60cm, Length stem 200cm, 10x E14, 40,0 kg, bronze finish |
| KELPC120ST | Ø 120cm, Height 60cm, Length stem 200cm, 10x E14, 30,0 kg, stainless steel |
| KELPC120COP | Ø 120cm, Height 60cm, Length stem 200cm, 10x E14, 30,0 kg, copper finish |
| KELPC120BR | Ø 120cm, Height 60cm, Length stem 200cm, 10x E14, 30,0 kg, messing finish |
| KELPC120BRA | Ø 120cm, Height 60cm, Length stem 200cm, 10x E14, 40,0 kg, brass aged finish |
| KELPC120BRG | Ø 120cm, Height 60cm, Length stem 200cm, 10x E14, 40,0 kg, brass grinded finish |

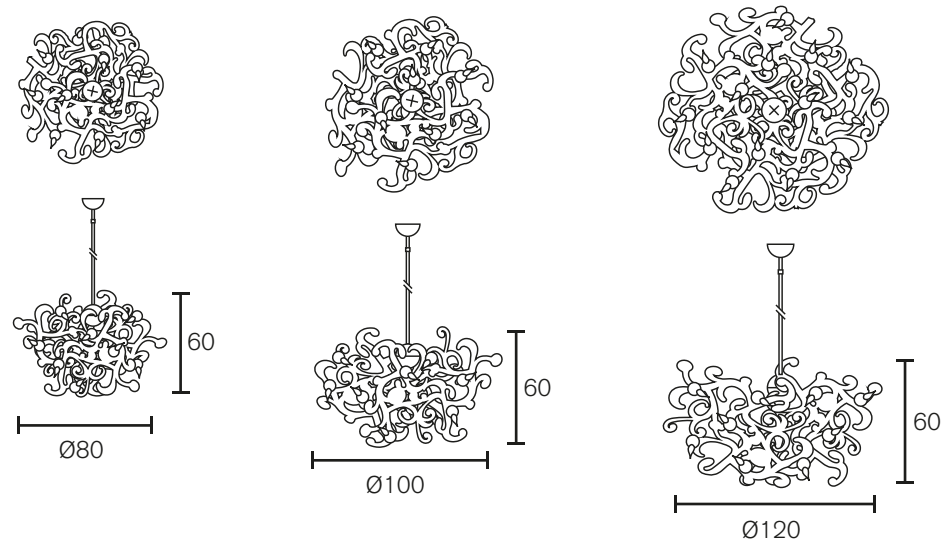

All hanging lamps are supplied with 2 meter electrical cable, 2 meter steel cable and a ceiling shade.
All chandeliers are supplied with 2 meter stem, 2 meter electrical cable and a ceiling shade.

Ceiling Lamp Round

| Art.nr. | Dimensions CM |
|------------|--|
| KELPP60BLM | Ø 60cm, Height 30cm, 6x E14, 13,0 kg, black matt finish |
| KELPP60WM | Ø 60cm, Height 30cm, 6x E14, 13,0 kg, white matt finish |
| KELPP60B | Ø 60cm, Height 30cm, 6x E14, 13,0 kg, bronze finish |
| KELPP60ST | Ø 60cm, Height 30cm, 6x E14, 13,0 kg, stainless steel |
| KELPP60COP | Ø 60cm, Height 30cm, 6x E14, 13,0 kg, copper finish |
| KELPP60BR | Ø 60cm, Height 30cm, 6x E14, 13,0 kg, brass finish |
| KELPP60BRA | Ø 60cm, Height 30cm, 6x E14, 13,0 kg, brass aged finish |
| KELPP60BRG | Ø 60cm, Height 30cm, 6x E14, 13,0 kg, brass grinded finish |
| KELPP80BLM | Ø 80cm, Height 30cm, 6x E14, 15,0 kg, black matt finish |
| KELPP80WM | Ø 80cm, Height 30cm, 6x E14, 15,0 kg, white matt finish |
| KELPP80B | Ø 80cm, Height 30cm, 6x E14, 15,0 kg, bronze finish |
| KELPP80ST | Ø 80cm, Height 30cm, 6x E14, 15,0 kg, stainless steel |
| KELPP80COP | Ø 80cm, Height 30cm, 6x E14, 15,0 kg, copper finish |
| KELPP80BR | Ø 80cm, Height 30cm, 6x E14, 15,0 kg, brass finish |
| KELPP80BRA | Ø 80cm, Height 30cm, 6x E14, 15,0 kg, brass aged finish |
| KELPP80BRG | Ø 80cm, Height 30cm, 6x E14, 15,0 kg, brass grinded finish |

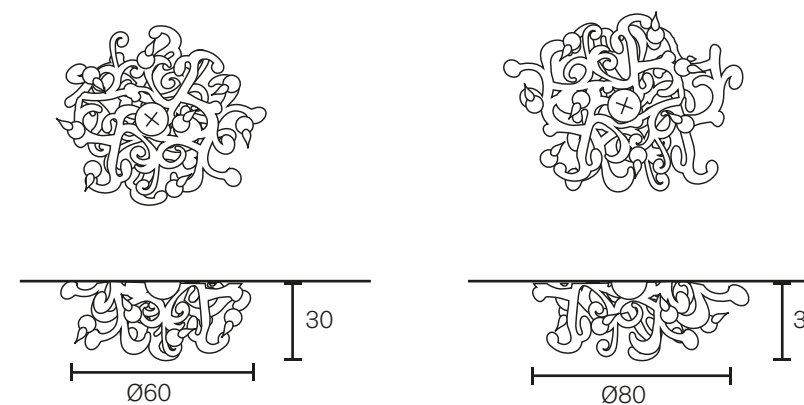

| Art.nr. | Dimensions CM |
|------------|---|
| 25KELPBLM | Length 25cm, Width 25cm, Height 35cm, Length steel cable 200cm, 1x E14, 1,5 kg, black matt finish |
| 25KELPWM | Length 25cm, Width 25cm, Height 35cm, Length steel cable 200cm, 1x E14, 1,5 kg, white matt finish |
| 25KELPB | Length 25cm, Width 25cm, Height 35cm, Length steel cable 200cm, 1x E14, 1,5 kg, bronze finish |
| 25KELPST | Length 25cm, Width 25cm, Height 35cm, Length steel cable 200cm, 1x E14, 1,5 kg, stainless steel |
| 25KELPCOP | Length 25cm, Width 25cm, Height 35cm, Length steel cable 200cm, 1x E14, 1,5 kg, copper finish |
| 25KELPBR | Length 25cm, Width 25cm, Height 35cm, Length steel cable 200cm, 1x E14, 1,5 kg, brass finish |
| 25KELPBRA | Length 25cm, Width 25cm, Height 35cm, Length steel cable 200cm, 1x E14, 1,5 kg, brass aged finish |
| 25KELPBRG | Length 25cm, Width 25cm, Height 35cm, Length steel cable 200cm, 1x E14, 1,5 kg, brass grinded finish |
| 50KELPBLM | Length 40cm, Width 40cm, Height 50cm, Length steel cable 200cm, 1x E14, 2,0 kg, black matt finish |
| 50KELPWM | Length 40cm, Width 40cm, Height 50cm, Length steel cable 200cm, 1x E14, 2,0 kg, white matt finish |
| 50KELPB | Length 40cm, Width 40cm, Height 50cm, Length steel cable 200cm, 1x E14, 2,0 kg, bronze finish |
| 50KELPST | Length 40cm, Width 40cm, Height 50cm, Length steel cable 200cm, 1x E14, 2,0 kg, stainless steel |
| 50KELPCOP | Length 40cm, Width 40cm, Height 50cm, Length steel cable 200cm, 1x E14, 2,0 kg, copper finish |
| 50KELPBR | Length 40cm, Width 40cm, Height 50cm, Length steel cable 200cm, 1x E14, 2,0 kg, brass finish |
| 50KELPBRA | Length 40cm, Width 40cm, Height 50cm, Length steel cable 200cm, 1x E14, 2,0 kg, brass aged finish |
| 50KELPBRG | Length 40cm, Width 40cm, Height 50cm, Length steel cable 200cm, 1x E14, 2,0 kg, brass grinded finish |
| 100KELPBLM | Length 80cm, Width 100cm, Height 80cm, Length steel cable 200cm, 5x E14, 15,0 kg, black matt finish |
| 100KELPWM | Length 80cm, Width 100cm, Height 80cm, Length steel cable 200cm, 5x E14, 15,0 kg, white matt finish |
| 100KELPB | Length 80cm, Width 100cm, Height 80cm, Length steel cable 200cm, 5x E14, 15,0 kg, bronze finish |
| 100KELPST | Length 80cm, Width 100cm, Height 80cm, Length steel cable 200cm, 5x E14, 15,0 kg, stainless steel |
| 100KELPCOP | Length 80cm, Width 100cm, Height 80cm, Length steel cable 200cm, 5x E14, 15,0 kg, copper finish |
| 100KELPBR | Length 80cm, Width 100cm, Height 80cm, Length steel cable 200cm, 5x E14, 15,0 kg, brass finish |
| 100KELPBRA | Length 80cm, Width 100cm, Height 80cm, Length steel cable 200cm, 5x E14, 15,0 kg, brass aged finish |
| 100KELPBRG | Length 80cm, Width 100cm, Height 80cm, Length steel cable 200cm, 5x E14, 15,0 kg, brass grinded finish |
| 150KELPBLM | Length 150cm, Width 150cm, Height 150cm, Length steel cable 200cm, 10x E14, 25,0 kg, black matt finish |
| 150KELPWM | Length 150cm, Width 150cm, Height 150cm, Length steel cable 200cm, 10x E14, 25,0 kg, white matt finish |
| 150KELPB | Length 150cm, Width 150cm, Height 150cm, Length steel cable 200cm, 10x E14, 25,0 kg, bronze finish |
| 150KELPST | Length 150cm, Width 150cm, Height 150cm, Length steel cable 200cm, 10x E14, 25,0 kg, stainless steel |
| 150KELPCOP | Length 150cm, Width 150cm, Height 150cm, Length steel cable 200cm, 10x E14, 25,0 kg, copper finish |
| 150KELPBR | Length 150cm, Width 150cm, Height 150cm, Length steel cable 200cm, 10x E14, 25,0 kg, brass finish |
| 150KELPBRA | Length 150cm, Width 150cm, Height 150cm, Length steel cable 200cm, 10x E14, 25,0 kg, brass aged finish |
| 150KELPBRG | Length 150cm, Width 150cm, Height 150cm, Length steel cable 200cm, 10x E14, 25,0 kg, brass grinded finish |

Central cover

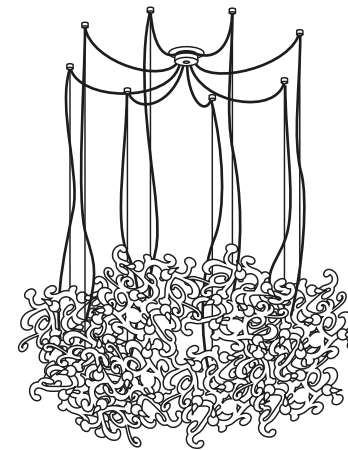

Satelite



Disc



Cover in line

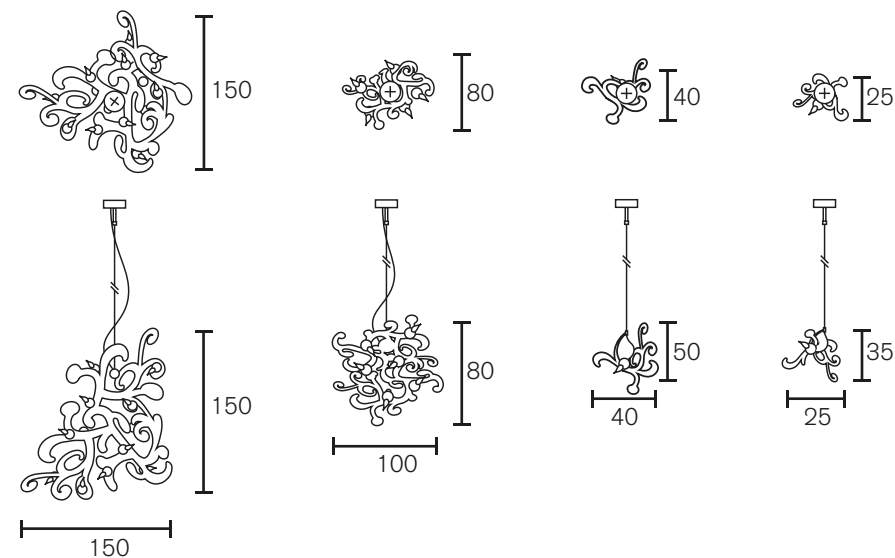
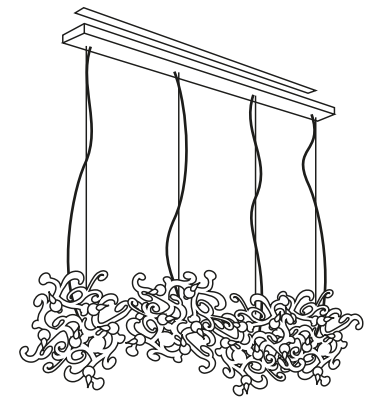

Cover in line

All hanging lamps are supplied with 2 meter electrical cable, 2 meter steel cable and a ceiling shade.
All chandeliers are supplied with 2 meter stem, 2 meter electrical cable and a ceiling shade.

All hanging lamps are supplied with 2 meter electrical cable, 2 meter steel cable and a ceiling shade.
All chandeliers are supplied with 2 meter stem, 2 meter electrical cable and a ceiling shade.

Collection Arthur 2014

Chandelier Conical

| Art.nr. | Dimensions CM |
|---------|---|
| ARCC60N | Ø 60cm, Height 70cm, Length chain 170cm, 8x E14, 30,0 kg, nickel finish |
| ARCC70N | Ø 70cm, Height 80cm, Length chain 170cm, 12x E14, 35,0 kg, nickel finish |
| ARCC80N | Ø 80cm, Height 100cm, Length chain 170cm, 14x E14, 40,0 kg, nickel finish |

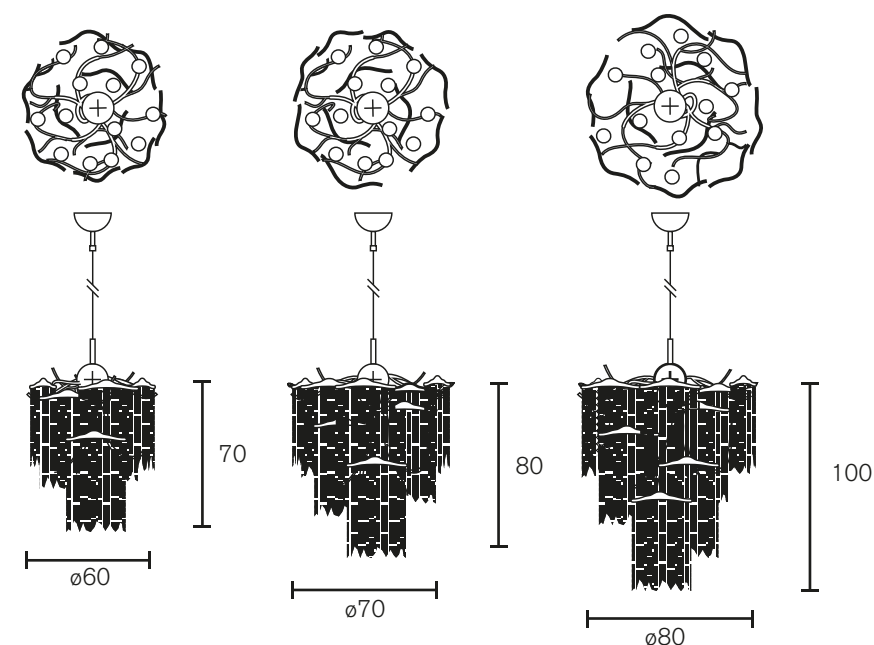

Chandelier Oval

| Art.nr. | Dimensions CM |
|----------|--|
| AROC120N | Length 120cm, Width 60cm, Height 55cm, Length chain 170cm, 12x E14, 35,0 kg, nickel finish |
| AROC140N | Length 140cm, Width 60cm, Height 55cm, Length chain 170cm, 12x E14, 36,0 kg, nickel finish |
| AROC160N | Length 160cm, Width 60cm, Height 55cm, Length chain 170cm, 16x E14, 45,0 kg, nickel finish |
| AROC180N | Length 180cm, Width 60cm, Height 55cm, Length chain 170cm, 16x E14, 47,0 kg, nickel finish |

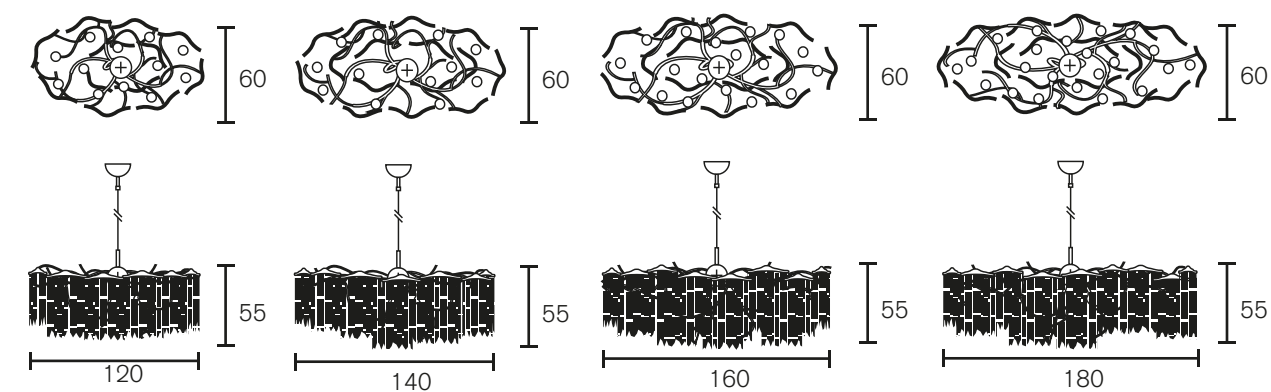

All chandeliers are supplied with 1,7 meter chain, 2 meter electrical cable and a ceiling shade. All floor- and table lamps are supplied with a dimmer.

Chandelier Round

| Art.nr. | Dimensions CM |
|---------|---|
| ARC80N | Ø 80cm, Height 50cm, Length chain 170cm, 12x E14, 30,0 kg, nickel finish |
| ARC100N | Ø 100cm, Height 55cm, Length chain 170cm, 14x E14, 40,0 kg, nickel finish |
| ARC120N | Ø 120cm, Height 70cm, Length chain 170cm, 16x E14, 60,0 kg, nickel finish |

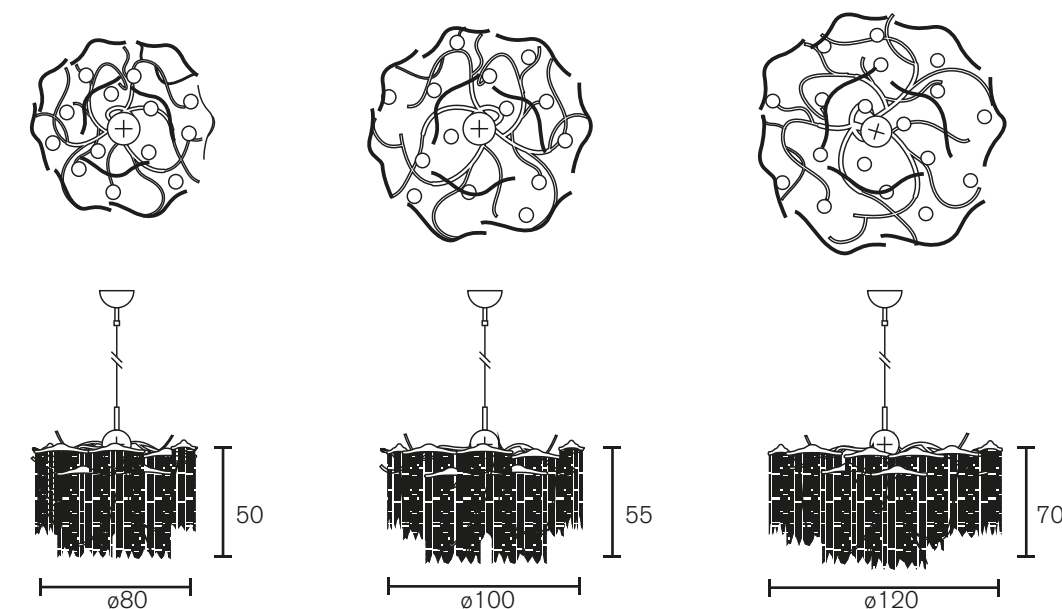

Ceiling Lamp Round

| Art.nr. | Dimensions CM |
|---------|---|
| ARP60N | Ø 60cm, Height 45cm, 4x E14, 25,0 kg, nickel finish |
| ARP80N | Ø 80cm, Height 45cm, 6x E14, 27,0 kg, nickel finish |

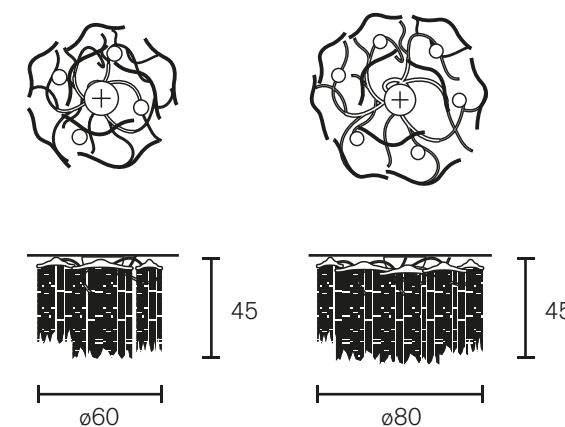

All chandeliers are supplied with 1,7 meter chain, 2 meter electrical cable and a ceiling shade. All floor- and table lamps are supplied with a dimmer.

Hanging Lamp

| Art.nr. | Dimensions CM |
|---------|---|
| AR18N | Ø 18cm, Height 75cm, Length steel cable 200cm, 3x E14, 10,0 kg, nickel finish |

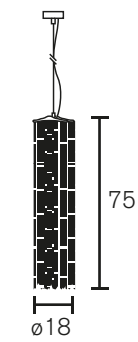

Floor Lamp

| Art.nr. | Dimensions CM |
|---------|--|
| ARF190N | Ø 30cm, Height 190cm, 5x E14, 32,0 kg, nickel finish |

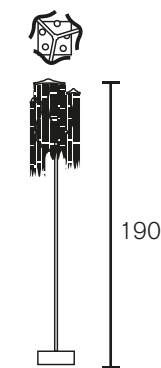
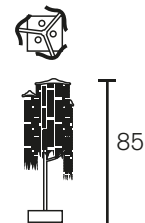

Table Lamp

| Art.nr. | Dimensions CM |
|---------|---|
| ART30N | Ø 30cm, Height 85cm, 3x E14, 17,0 kg, nickel finish |



Wall Lamp

| Art.nr. | Dimensions CM |
|---------|---|
| ARW50N | Width 20cm, Height 50cm, Depth 12cm, 1x E14, 7,0 kg, nickel finish |
| ARW70N | Width 30cm, Height 70cm, Depth 12cm, 2x E14, 10,0 kg, nickel finish |

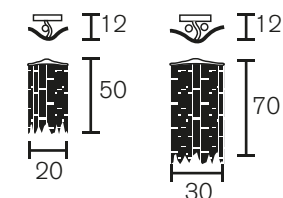

All chandeliers are supplied with 1,7 meter chain, 2 meter electrical cable and a ceiling shade. All floor- and table lamps are supplied with a dimmer.

Collection Victoria 2014

Chandelier Conical

| Art.nr. | Dimensions CM |
|---------|---|
| VCC60N | Ø 60cm, Height 70cm, Length chain 170cm, 8x E14, 24,0 kg, nickel finish |
| VCC70N | Ø 70cm, Height 80cm, Length chain 170cm, 12x E14, 28,0 kg, nickel finish |
| VCC80N | Ø 80cm, Height 100cm, Length chain 170cm, 14x E14, 30,0 kg, nickel finish |

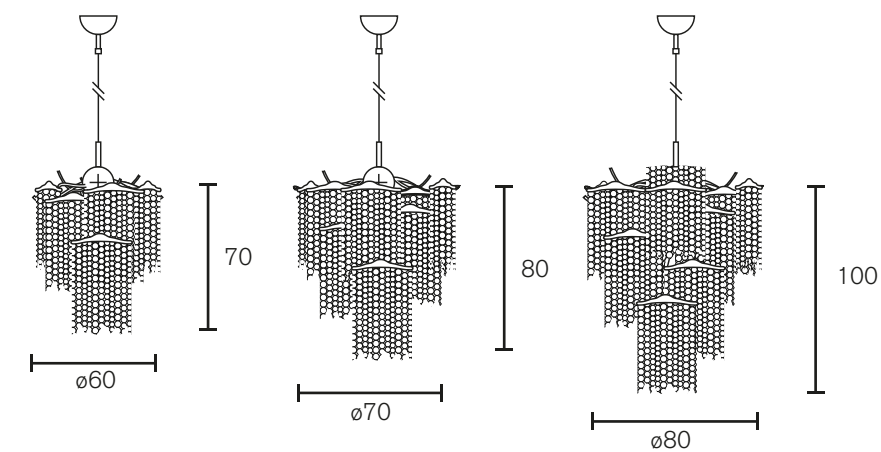
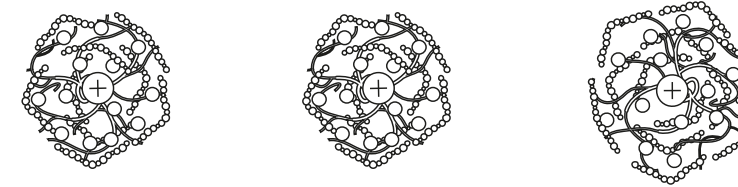

Chandelier Oval

| Art.nr. | Dimensions CM |
|---------|--|
| VOC120N | Length 120cm, Width 60cm, Height 55cm, Length chain 170cm, 12x E14, 22,0 kg, nickel finish |
| VOC140N | Length 140cm, Width 60cm, Height 55cm, Length chain 170cm, 12x E14, 26,0 kg, nickel finish |
| VOC160N | Length 160cm, Width 60cm, Height 55cm, Length chain 170cm, 16x E14, 26,0 kg, nickel finish |
| VOC180N | Length 180cm, Width 60cm, Height 55cm, Length chain 170cm, 16x E14, 36,0 kg, nickel finish |

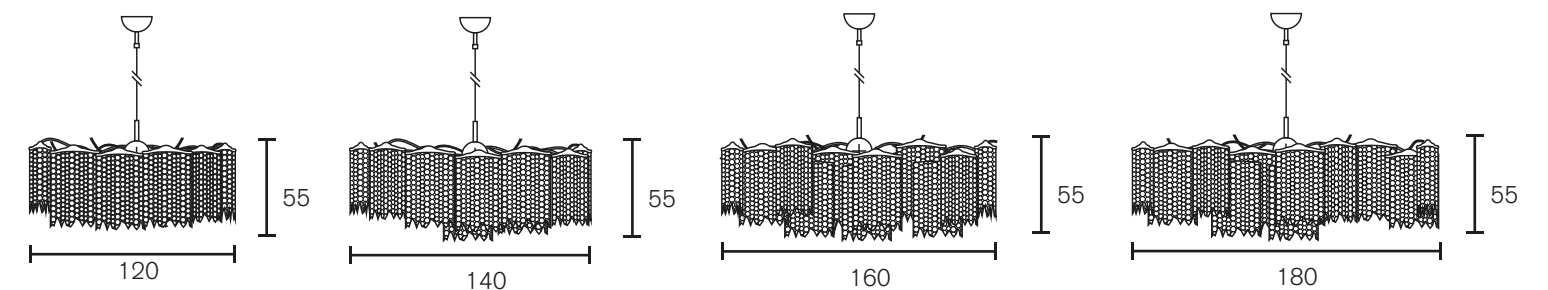
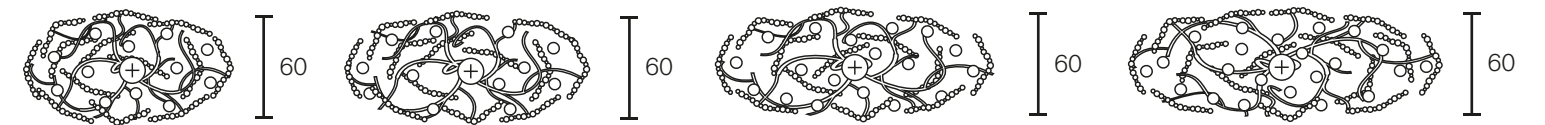

All chandeliers are supplied with 1,7 meter chain, 2 meter electrical cable and a ceiling shade. All floor- and table lamps are supplied with a dimmer.

Chandelier Round

| Art.nr. | Dimensions CM |
|---------|---|
| VC80N | Ø 80cm, Height 50cm, Length chain 170cm, 12x E14, 25,0 kg, nickel finish |
| VC100N | Ø 100cm, Height 55cm, Length chain 170cm, 14x E14, 29,0 kg, nickel finish |
| VC120N | Ø 120cm, Height 70cm, Length chain 170cm, 16x E14, 43,0 kg, nickel finish |

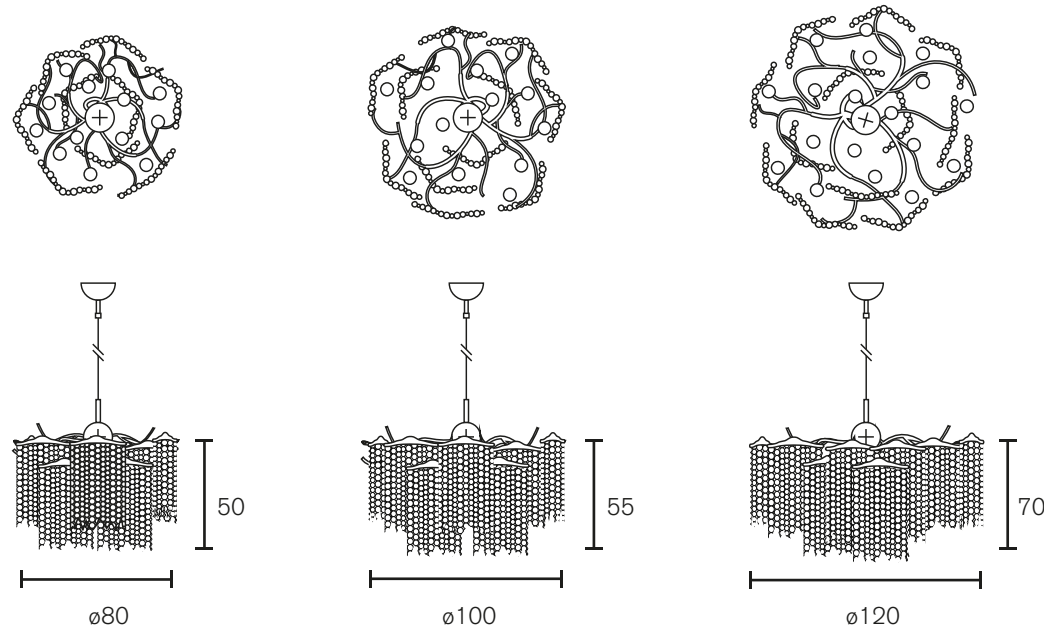

Ceiling Lamp

| Art.nr. | Dimensions CM |
|---------|---|
| VP60N | Ø 60cm, Height 45cm, 4x E14, 13,0 kg, nickel finish |
| VP80N | Ø 80cm, Height 45cm, 6x E14, 20,0 kg, nickel finish |

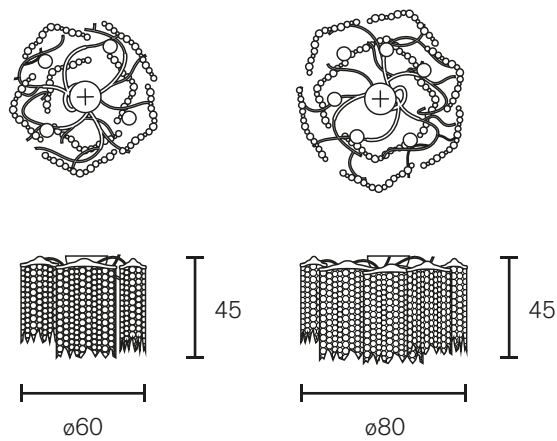

All chandeliers are supplied with 1,7 meter chain, 2 meter electrical cable and a ceiling shade. All floor- and table lamps are supplied with a dimmer.

Hanging Lamp

| Art.nr. | Dimensions CM |
|---------|--|
| VC18N | Ø 18cm, Height 75cm, Length steel cable 200cm, 3x E14, 7,0 kg, nickel finish |

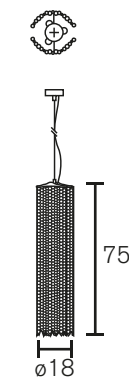

Floor Lamp

| Art.nr. | Dimensions CM |
|---------|--|
| VF190N | Ø 30cm, Height 190cm, 5x E14, 27,0 kg, nickel finish |

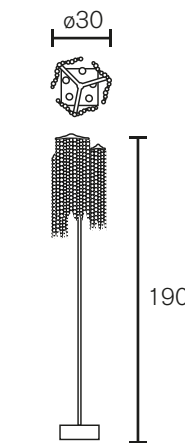
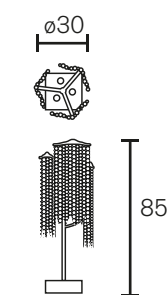

Table Lamp

| Art.nr. | Dimensions CM |
|---------|---|
| VT30N | Ø 30cm, Height 85cm, 3x E14, 12,0 kg, nickel finish |



Wall Lamp

| Art.nr. | Dimensions CM |
|---------|--|
| VW50N | Width 20cm, Height 50cm, Depth 12cm, 1x E14, 5,0 kg, nickel finish |
| VW70N | Width 30cm, Height 70cm, Depth 12cm, 2x E14, 8,0 kg, nickel finish |

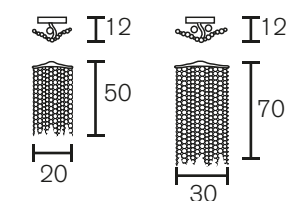

All chandeliers are supplied with 1,7 meter chain, 2 meter electrical cable and a ceiling shade. All floor- and table lamps are supplied with a dimmer.

Collection Sultans Of Swing 2012

Chandelier conical

| Art.nr. | Dimensions CM |
|-----------|--|
| SOSCC60N | Ø 60cm, Height 80cm, Length chain 170cm, 12x E14, 23,0 kg, nickel finish |
| SOSCC80N | Ø 80cm, Height 100cm, Length chain 170cm, 14x E14, 30,0 kg, nickel finish |
| SOSCC100N | Ø 100cm, Height 120cm, Length chain 170cm, 16x E14, 37,0 kg, nickel finish |

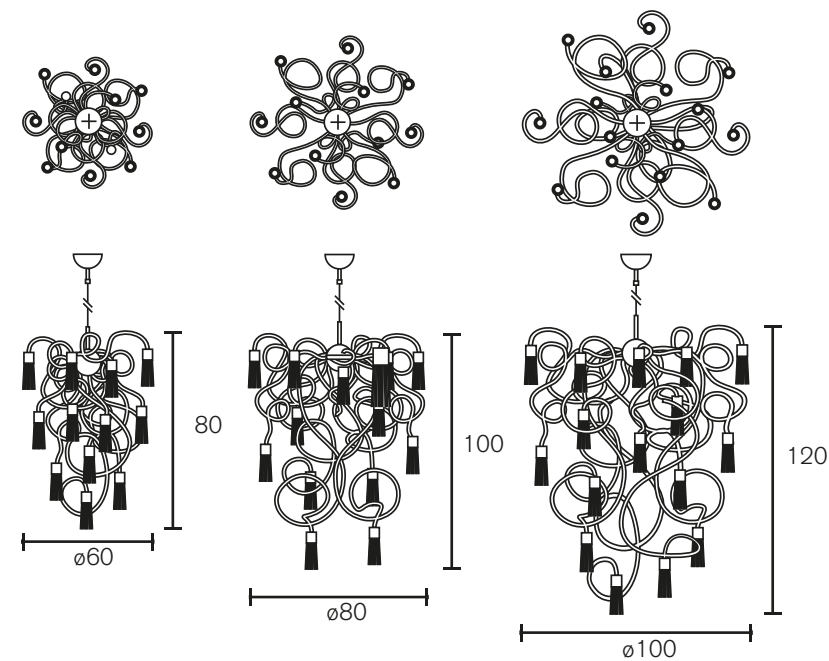

Chandelier Oval

| Art.nr. | Dimensions CM |
|-----------|--|
| SOSOC120N | Length 120cm, Width 60cm, Height 55cm, Length chain 170cm, 14x E14, 26,0 kg, nickel finish |
| SOSOC140N | Length 140cm, Width 70cm, Height 55cm, Length chain 170cm, 14x E14, 35,0 kg, nickel finish |
| SOSOC160N | Length 160cm, Width 70cm, Height 55cm, Length chain 170cm, 14x E14, 32,0 kg, nickel finish |

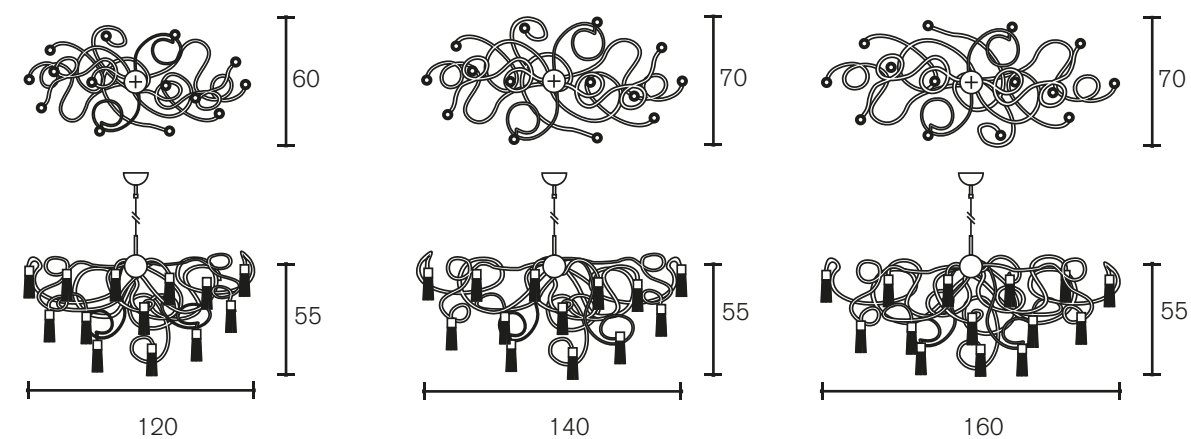

All chandeliers are supplied with 1,7 meter chain, 2 meter electrical cable and a ceiling shade. All floor- and table lamps are supplied with a dimmer.

Chandelier round

| Art.nr. | Dimensions CM |
|----------|---|
| SOSC60N | Ø 60cm, Height 50cm, Length chain 170cm, 8x E14, 23,0 kg, nickel finish |
| SOSC80N | Ø 80cm, Height 55cm, Length chain 170cm, 12x E14, 30,0 kg, nickel finish |
| SOSC100N | Ø 100cm, Height 60cm, Length chain 170cm, 14x E14, 38,0 kg, nickel finish |

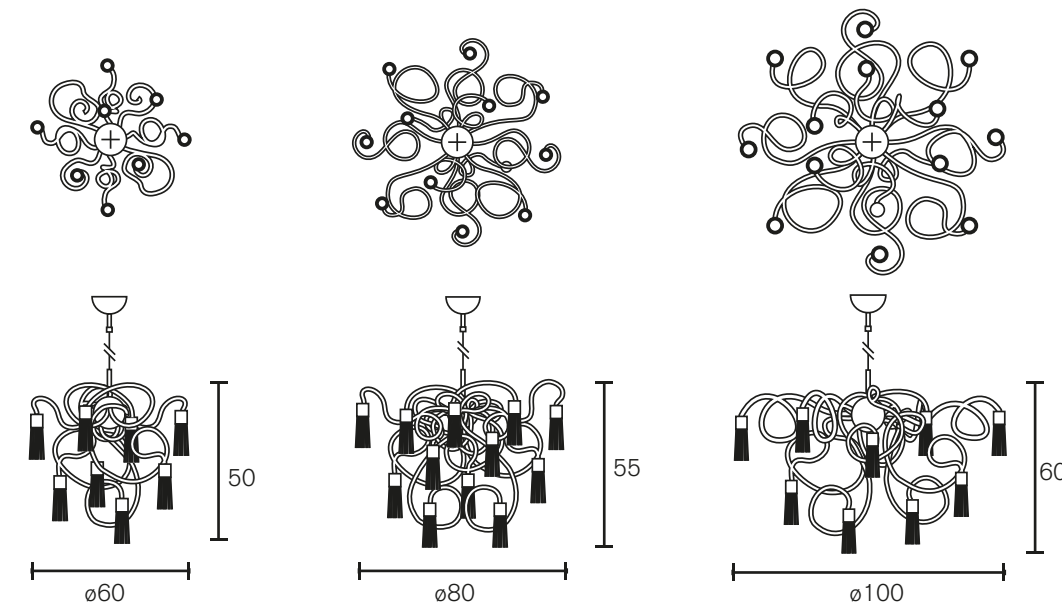

Hanging lamp

| Art.nr. | Dimensions CM |
|----------|---|
| SOSH120N | Length 120cm, Width 40cm, Height 45cm, Length chain 170cm, 6x E14, 10,0 kg, nickel finish |
| SOSH140N | Length 140cm, Width 40cm, Height 45cm, Length chain 170cm, 6x E14, 15,0 kg, nickel finish |
| SOSH160N | Length 160cm, Width 40cm, Height 45cm, Length chain 170cm, 8x E14, 20,0 kg, nickel finish |

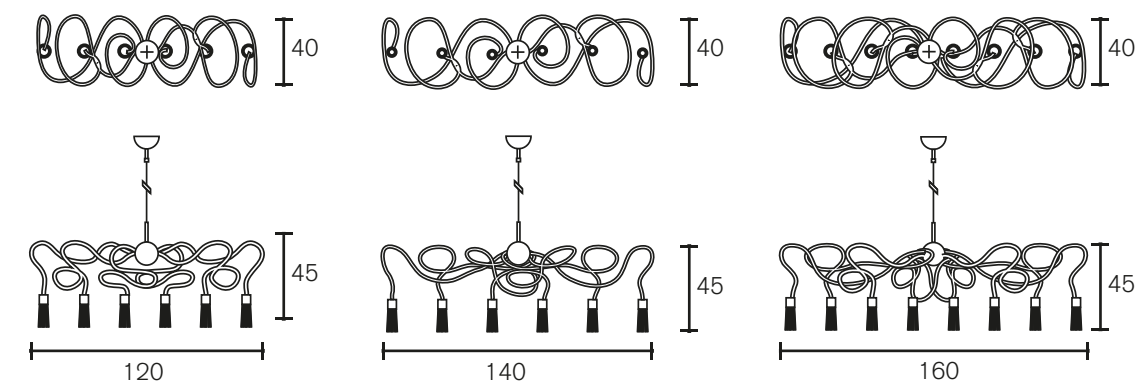

All chandeliers are supplied with 1,7 meter chain, 2 meter electrical cable and a ceiling shade. All floor- and table lamps are supplied with a dimmer.

Ceiling lamp

| Art.nr. | Dimensions CM |
|----------|--|
| SOSP60N | Ø 60cm, Height 35cm, 6x E14, 10,0 kg, nickel finish |
| SOSP80N | Ø 80cm, Height 35cm, 8x E14, 13,0 kg, nickel finish |
| SOSP100N | Ø 100cm, Height 35cm, 8x E14, 18,0 kg, nickel finish |

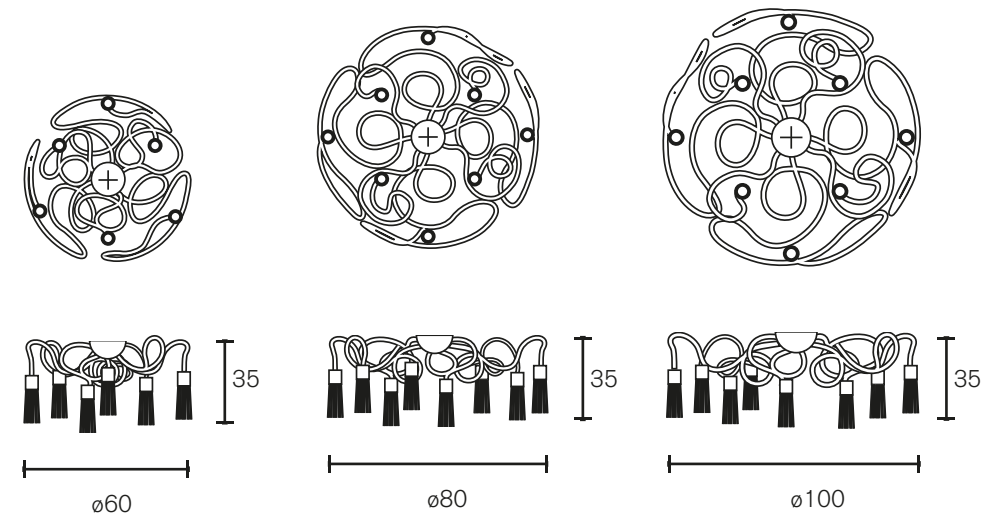
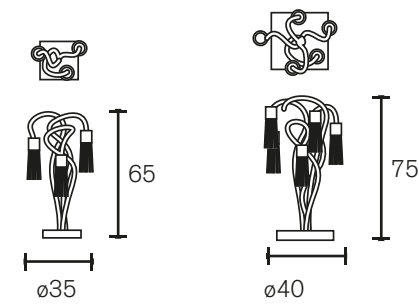

Table lamp

| Art.nr. | Dimensions CM |
|---------|---|
| SOST65N | Ø 35cm, Height 65cm, 3x E14, 10,0 kg, nickel finish |
| SOST75N | Ø 40cm, Height 75cm, 5x E14, 10,0 kg, nickel finish |



Wall Lamp

| Art.nr. | Dimensions CM |
|---------|---|
| SOSW36N | Width 12cm, Height 36cm, Depth 12cm, 1x E14, 3,5 kg, nickel finish |
| SOSW40N | Width 25cm, Height 40cm, Depth 12cm, 2x E14, 5,0 kg, nickel finish |
| SOSW50N | Width 25cm, Height 50cm, Depth 12cm, 3x E14, 11,0 kg, nickel finish |
| SOSW65N | Width 30cm, Height 65cm, Depth 12cm, 4x E14, 14,0 kg, nickel finish |

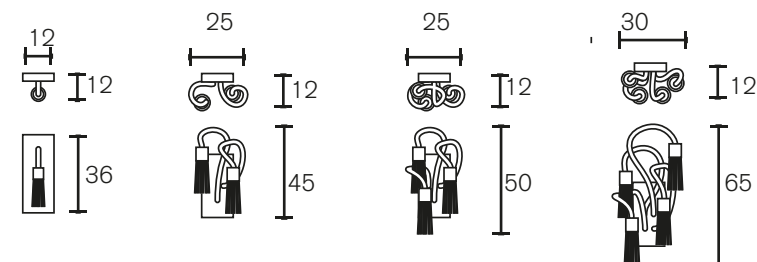

All chandeliers are supplied with 1,7 meter chain, 2 meter electrical cable and a ceiling shade. All floor- and table lamps are supplied with a dimmer.

Sultans Of Swing Adagio

| Art.nr. | Dimensions CM |
|----------|---|
| 100SOSST | Ø 30cm, Height 100cm, 1x E14, 2,5 kg, stainless steel |

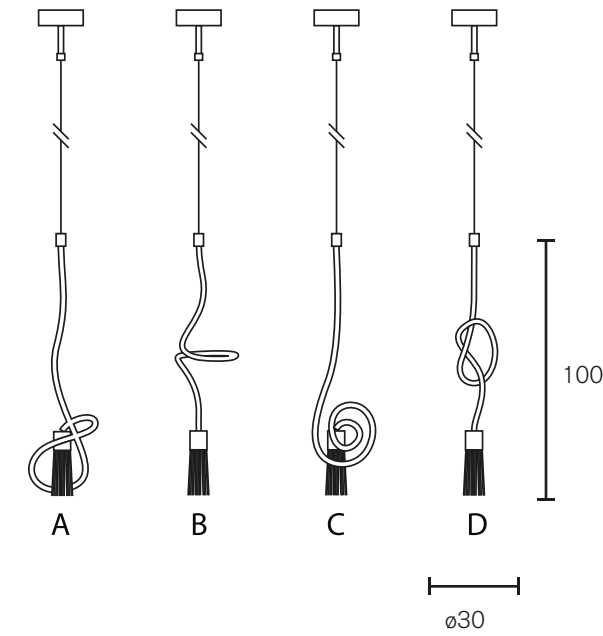

Sultans Of Swing Adagio

| Art.nr. | Dimensions CM |
|---------|--|
| 55SOSST | Ø 15cm, Height 55cm, 1x E14, 2 kg, stainless steel |

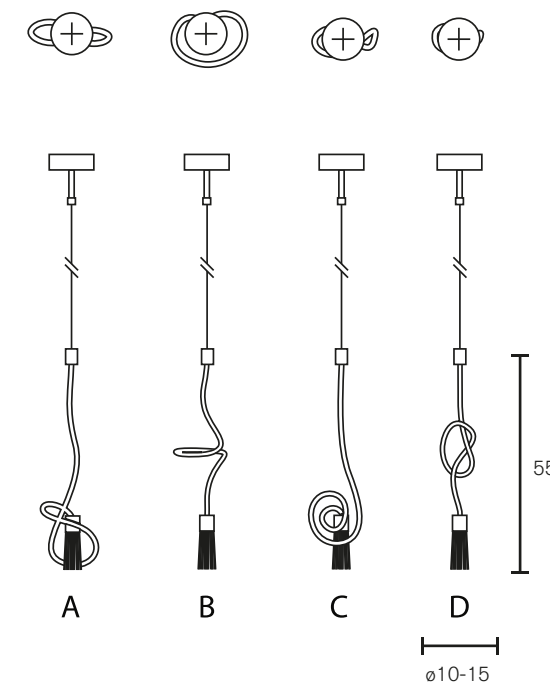

*Order 6-12 pieces: 10% discount *Order 13-18 pieces: 15% discount *Order 19 pieces or more: 20% discount

All chandeliers are supplied with 1,7 meter chain, 2 meter electrical cable and a ceiling shade. All floor- and table lamps are supplied with a dimmer.

Collection Diamonds From Amsterdam 2011

Hanging Lamp

| Art.nr. | Dimensions CM |
|----------|---|
| DFAC80ST | Ø 80cm, Width 20cm, Length chain 57cm, 14x G9, 40,0 kg, stainless steel |

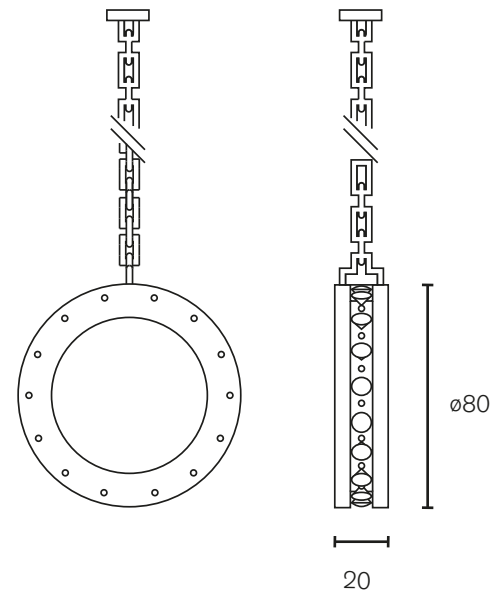

Collection Table D'amis 2011

Hanging Lamp Long

| Art.nr. | Dimensions CM |
|------------|--|
| TABL90BLM | Length 90cm, Width 35cm, Height 42cm, Length steel cable 200cm, 30,0 kg, 8x G9 uplight, 8x G9 downlight, black matt finish |
| TABL135BLM | Length 135cm, Width 35cm, Height 42cm, Length steel cable 200cm, 35,0 kg, 8x G9 uplight, 10x G9 downlight, black matt finish |
| TABL165BLM | Length 165cm, Width 35cm, Height 42cm, Length steel cable 200cm, 44,0 kg, 8x G9 uplight, 12x G9 downlight, black matt finish |
| TABL195BLM | Length 195cm, Width 35cm, Height 42cm, Length steel cable 200cm, 47,0 kg, 8x G9 uplight, 14x G9 downlight, black matt finish |

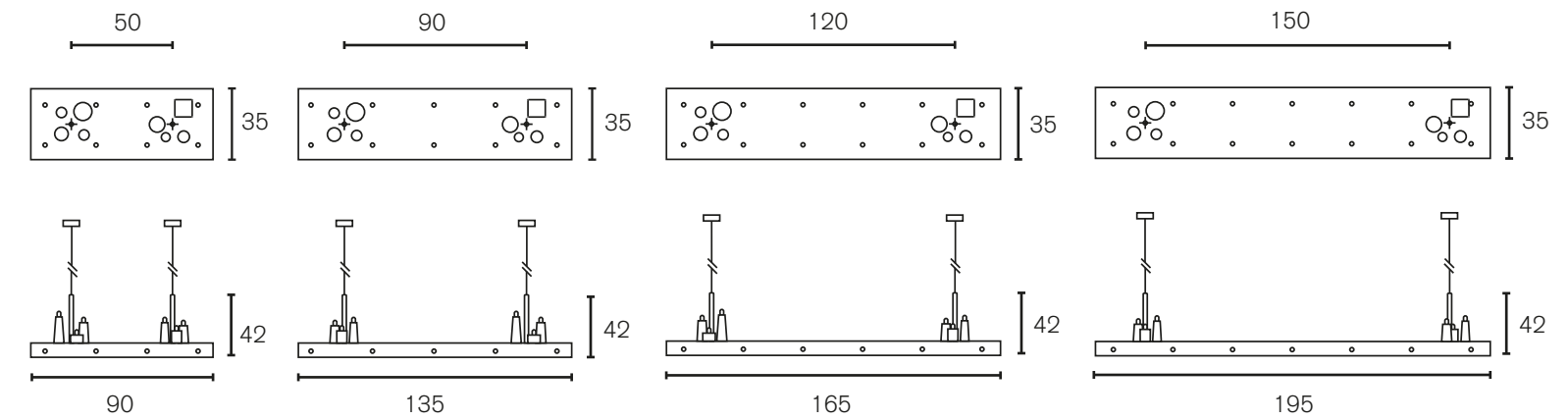

The Lighting Sculpture is supplied with a 40 cm chain, 2 meter electrical cable and a ceiling shade. Chain can be customised on request.

All square hanging lamps are supplied with 2 meter stem, 2 meter electrical and a shade. The length can easily be adjusted on site. All hanging and round lamps are supplied with 2 meter steel- an electrical cable and one small ceiling shade. Long ceiling shade with 2 steel cable connections available on request.

Collection La Vie En Rose 2014

A bouquet can be connected on its own with a ceiling cover or, when used as part of a composition, connected with a ceiling screw and attached with a electric cable to the ceiling crown of the composition.

The Single Rose Decorative can be connected to a ceiling crown as part of a composition. It can also be connected straight to the ceiling on its own using a ceiling screw. A Single Rose with Light can be connected to a ceiling crown as part of a composition. On its own a Single Rose with Light can be connected with a ceiling cover.

Ceiling Crown

| Art.nr. | Dimensions CM |
|-----------|--------------------------------|
| VERCH3XN | Ø 60cm, 2,5 kg, nickel finish |
| VERCH6XN | Ø 80cm, 2,9 kg, nickel finish |
| VERCH8XN | Ø 120cm, 3,3 kg, nickel finish |
| VERCH12XN | Ø 120cm, 3,5 kg, nickel finish |
| VERCH16XN | Ø 120cm, 4,0 kg, nickel finish |

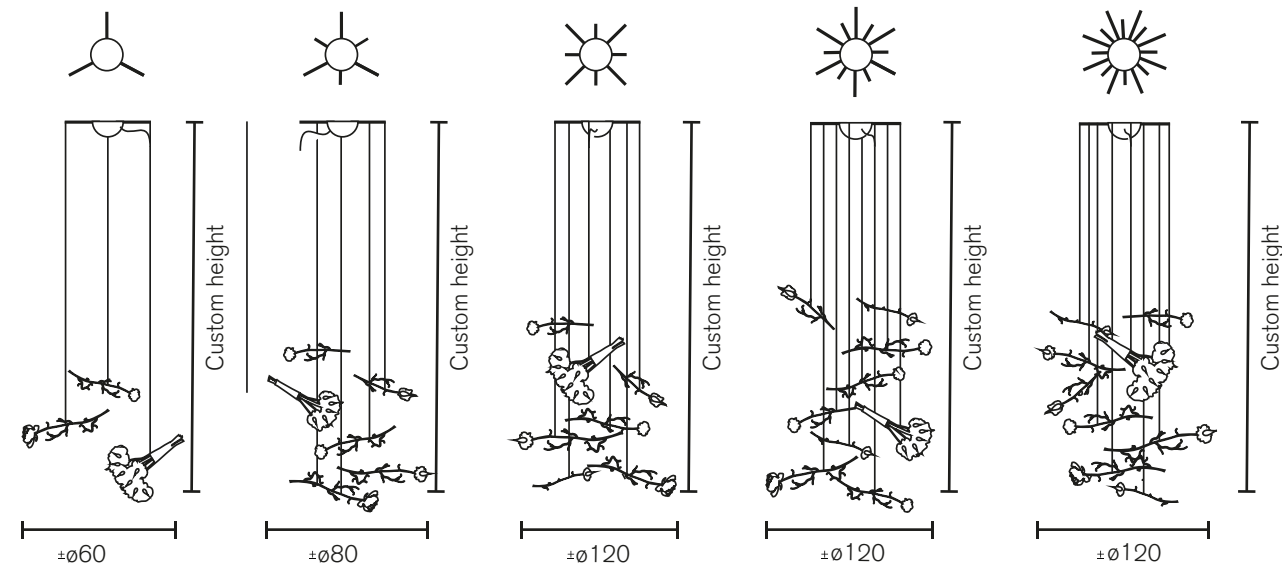

Bouquet

| Art.nr. | Dimensions CM |
|-----------|--|
| VERHB40N | Ø 40cm, Length 80cm, Length steel cable 200cm, 5x E14, 10,0 kg, nickel finish |
| VERHB60N | Ø 60cm, Length 80cm, Length steel cable 200cm, 7x E14, 11,0 kg, nickel finish |
| VERHB80N | Ø 80cm, Length 100cm, Length steel cable 200cm, 10x E14, 22,0 kg, nickel finish |
| VERHB100N | Ø 100cm, Length 120cm, Length steel cable 200cm, 12x E14, 30,0 kg, nickel finish |

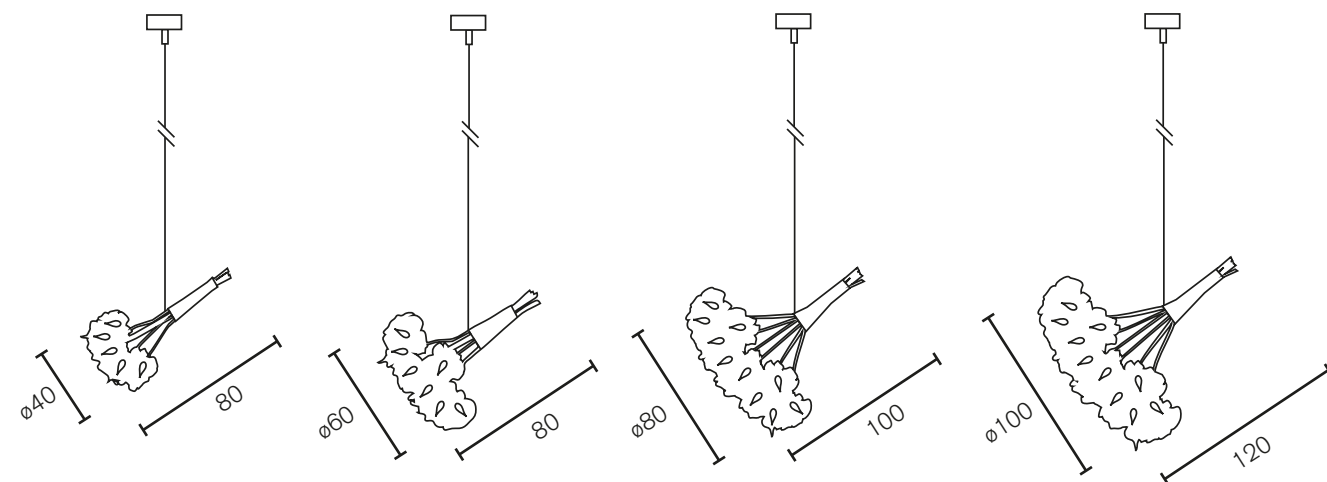

All hanging lamps are supplied with 2 meter steel- and electrical cable and a ceiling shade. All rose objects are standard supplied with 3 meter steel cable and 3 meter electrical cable. Loose bouquets and single roses are to be attached directly to the ceiling, separate from the ceiling cover.

Single Decoration Rose

| Art.nr. | Dimensions CM |
|-----------|---|
| VERSRD80N | Length 85cm, Width 20cm, Height 20cm, Length steel cable 200cm, 1,0 kg, nickel finish |

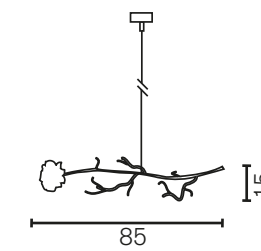

Single Light Rose

| Art.nr. | Dimensions CM |
|-----------|---|
| VERSRL80N | Length 85cm, Width 15cm, Height 15cm, Length steel cable 200cm, 1x E14, 1,0 kg, nickel finish |

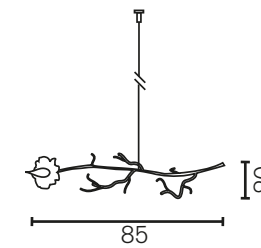

Hanging lamp

| Art.nr. | Dimensions CM |
|-----------|--|
| VERHL120N | Length 120cm, Width 40cm, Height 40cm, Length steel cable 200cm, 8x E14, 5,0 kg, nickel finish |
| VERHL140N | Length 140cm, Width 40cm, Height 40cm, Length steel cable 200cm, 8x E14, 8,3 kg, nickel finish |
| VERHL160N | Length 160cm, Width 40cm, Height 40cm, Length steel cable 200cm, 10x E14, 11,0 kg, nickel finish |

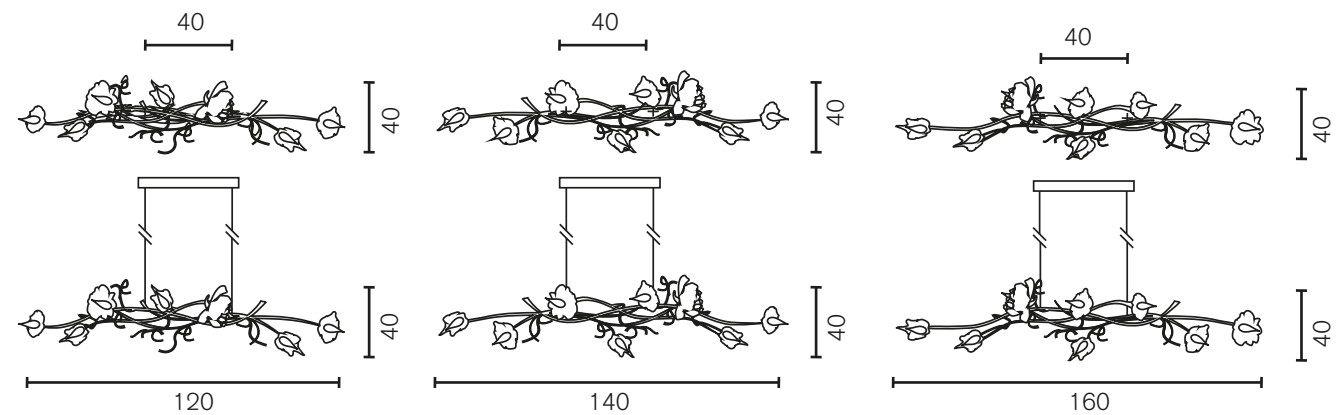

Wall lamp

| Art.nr. | Dimensions CM |
|---------|---|
| VERW35N | Length 35cm, Height 65cm, Depth 20cm, 3x E14, 8,0 kg, nickel finish |

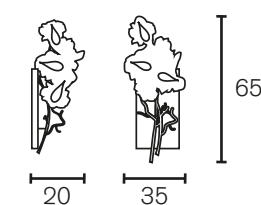

All hanging lamps are supplied with 2 meter steel- and electrical cable and a ceiling shade. All rose objects are standard supplied with 3 meter steel cable and 3 meter electrical cable. Loose bouquets and single roses are to be attached directly to the ceiling, separate from the ceiling cover.

Collection Coco 2009

Chandelier Oval

| Art.nr. | Dimensions CM |
|-------------|--|
| COCOCO120BL | Length 120cm, Width 60cm, Height 65cm, Length chain 170cm, 12x E14, 37,0 kg, black finish |
| COCOCO120N | Length 120cm, Width 60cm, Height 65cm, Length chain 170cm, 12x E14, 37,0 kg, nickel finish |
| COCOCO140BL | Length 140cm, Width 60cm, Height 65cm, Length chain 170cm, 12x E14, 39,0 kg, black finish |
| COCOCO140N | Length 140cm, Width 60cm, Height 65cm, Length chain 170cm, 12x E14, 39,0 kg, nickel finish |
| COCOCO160BL | Length 160cm, Width 60cm, Height 65cm, Length chain 170cm, 16x E14, 62,0 kg, black finish |
| COCOCO160N | Length 160cm, Width 60cm, Height 65cm, Length chain 170cm, 16x E14, 62,0 kg, nickel finish |

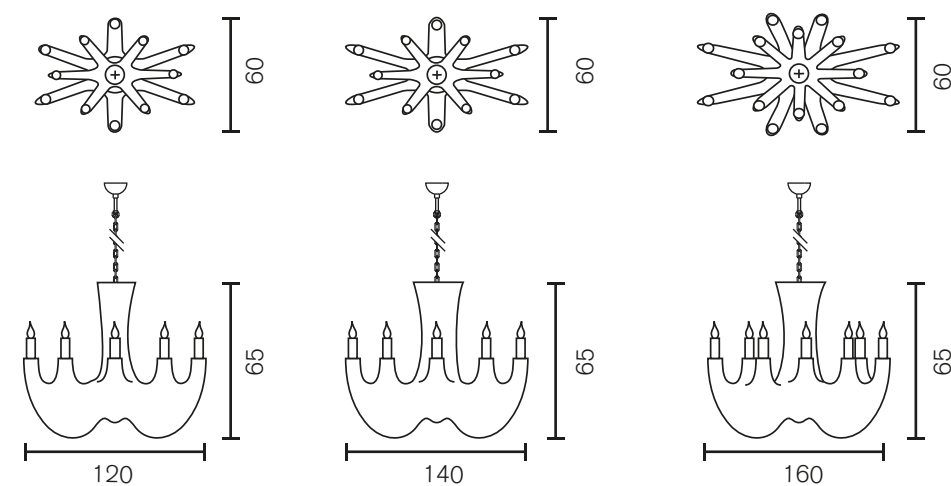

Chandelier Round

| Art.nr. | Dimensions CM |
|-------------|--|
| COCOCC60BL | Ø 60cm, Height 75cm, Length chain 170cm, 12x E14, 38,0 kg, black finish |
| COCOCC60N | Ø 60cm, Height 75cm, Length chain 170cm, 12x E14, 38,0 kg, nickel finish |
| COCOCC80BL | Ø 80cm, Height 95cm, Length chain 170cm, 12x E14, 40,0 kg, black finish |
| COCOCC80N | Ø 80cm, Height 95cm, Length chain 170cm, 12x E14, 40,0 kg, nickel finish |
| COCOCC100BL | Ø 100cm, Height 100cm, Length chain 170cm, 12x E14, 49,0 kg, black finish |
| COCOCC100N | Ø 100cm, Height 100cm, Length chain 170cm, 12x E14, 49,0 kg, nickel finish |
| COCOCC120BL | Ø 120cm, Height 120cm, Length chain 170cm, 15x E14, 41,0 kg, black finish |
| COCOCC120N | Ø 120cm, Height 120cm, Length chain 170cm, 15x E14, 41,0 kg, nickel finish |

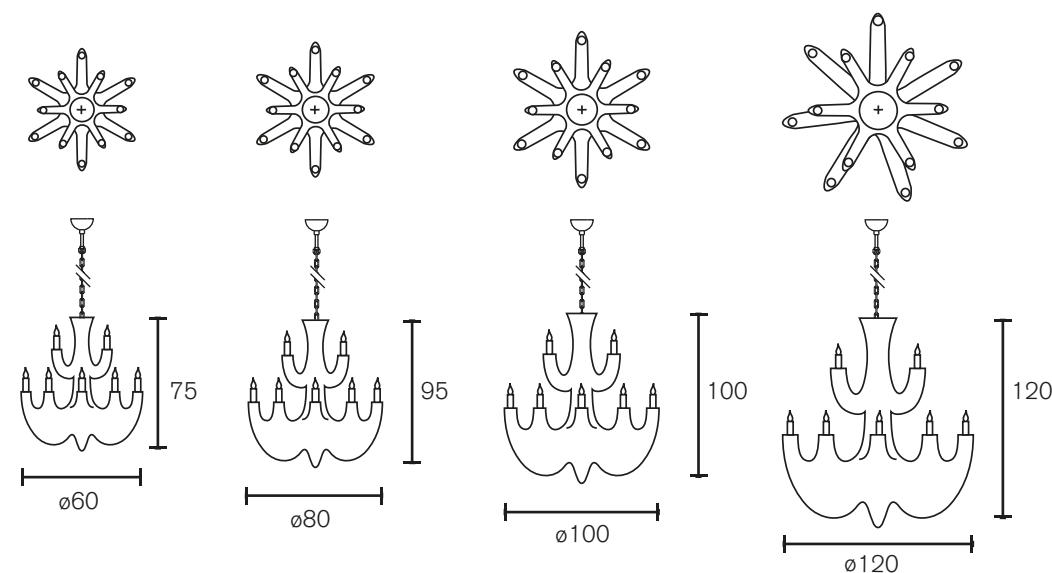

All lamps are supplied with 1,7 meter chain, 2 meter electrical cable and a ceiling shade. White finish on request.

Ceiling Lamp Round

| Art.nr. | Dimensions CM |
|------------|---|
| COCOP60BL | Ø 60cm, Height 30cm, 5x E14, 16,0 kg, black finish |
| COCOP60N | Ø 60cm, Height 30cm, 5x E14, 16,0 kg, nickel finish |
| COCOP80BL | Ø 80cm, Height 35cm, 6x E14, 23,0 kg, black finish |
| COCOP80N | Ø 80cm, Height 35cm, 6x E14, 23,0 kg, nickel finish |
| COCOP100BL | Ø 100cm, Height 35cm, 8x E14, 25,0 kg, black finish |
| COCOP100N | Ø 100cm, Height 35cm, 8x E14, 25,0 kg, nickel finish |
| COCOP120BL | Ø 120cm, Height 35cm, 10x E14, 27,0 kg, black finish |
| COCOP120N | Ø 120cm, Height 35cm, 10x E14, 27,0 kg, nickel finish |

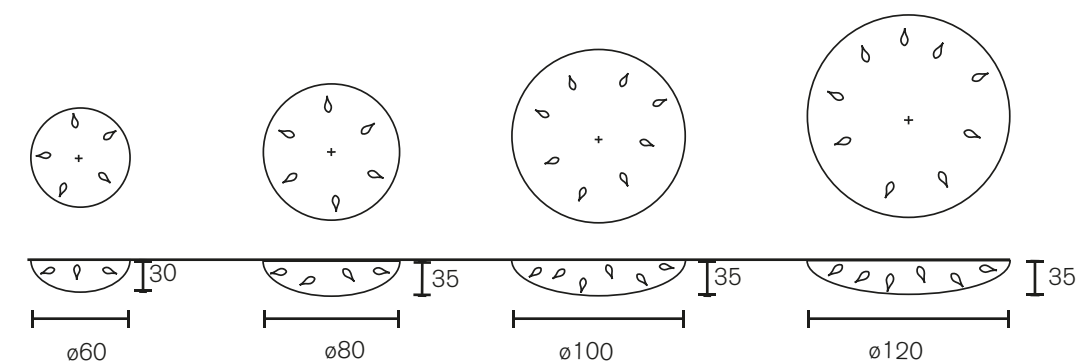

Wall Lamp

| Art.nr. | Dimensions CM |
|-------------|---|
| COCOW36BL-L | Width 12cm, Height 36cm, Depth 10cm, 1x E14, 3,0 kg, black finish, left version |
| COCOW36BL-R | Width 12cm, Height 36cm, Depth 10cm, 1x E14, 3,0 kg, black finish, right version |
| COCOW36N-L | Width 12cm, Height 36cm, Depth 10cm, 1x E14, 3,0 kg, nickel finish, left version |
| COCOW36N-R | Width 12cm, Height 36cm, Depth 10cm, 1x E14, 3,0 kg, nickel finish, right version |
| COCOW35BL | Width 35cm, Height 50cm, Depth 30cm, 3x E14, 7,0 kg, black finish |
| COCOW35N | Width 35cm, Height 50cm, Depth 30cm, 3x E14, 7,0 kg, nickel finish |

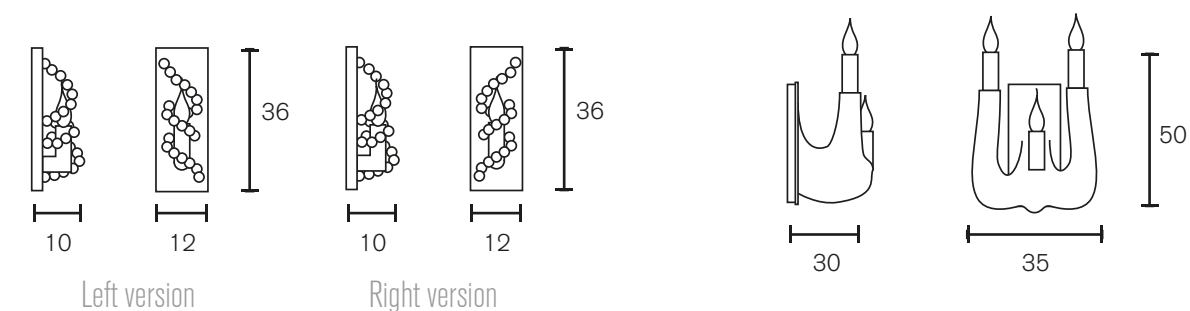

All lamps are supplied with 1,7 meter chain, 2 meter electrical cable and a ceiling shade. White finish on request.

Collection Floating Candles 2015

The Floating Candles concept offers the possibility to combine several separate candle models, which can differ mutually, into a new fixture. Use them single, hang them in line or create a chandelier. The following options can be selected:

- FCB18** Candle basic model
- FCDL18** Candle on platter, with downlight in it

Single
Use a single Floating Candle. This will be supplied with a single ceiling cover

In Line
It is possible to combine a series of several candles in line. This fixture can for example be used above a table or desk. For this fixture we recommend the use of one or more downlights.

Chandelier
Beside this, it is also possible to compose a chandelier, consisting of different Floating Candles.

Chandelier

| Art.nr. | Dimensions CM |
|----------|--|
| FCB18WM | Ø 12cm, Height 43cm, 1 x E14, 2,4 kg, white matt finish |
| FCB18ST | Ø 12cm, Height 43cm, 1 x E14, 2,4 kg, stainless steel |
| FCDL18WM | Ø 16cm, Height 43cm, 1 x E14, 3,3 kg, 1 spot, downlight, white matt finish |
| FCDL18ST | Ø 16cm, Height 43cm, 1 x E14, 3,3 kg, 1 spot, downlight, stainless steel |

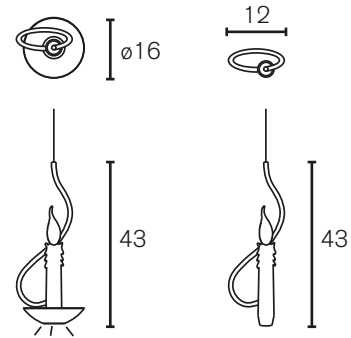

Ceiling Cover

| Art.nr. | Dimensions CM |
|-----------|---|
| FC2ILBALK | Length 37cm, Width 12cm, Height 3cm, 3,5 kg, stainless steel |
| FC3ILBALK | Length 62cm, Width 12cm, Height 3cm, 3,0 kg, stainless steel |
| FC4ILBALK | Length 87cm, Width 12cm, Height 3cm, 6,0 kg, stainless steel |
| FC5ILBALK | Length 112cm, Width 12cm, Height 3cm, 6,5 kg, stainless steel |
| FC6ILBALK | Length 137cm, Width 12cm, Height 3cm, 5,0 kg, stainless steel |
| FC7ILBALK | Length 162cm, Width 12cm, Height 3cm, 5,7 kg, stainless steel |
| FC8ILBALK | Length 187cm, Width 12cm, Height 3cm, 6,5 kg, stainless steel |

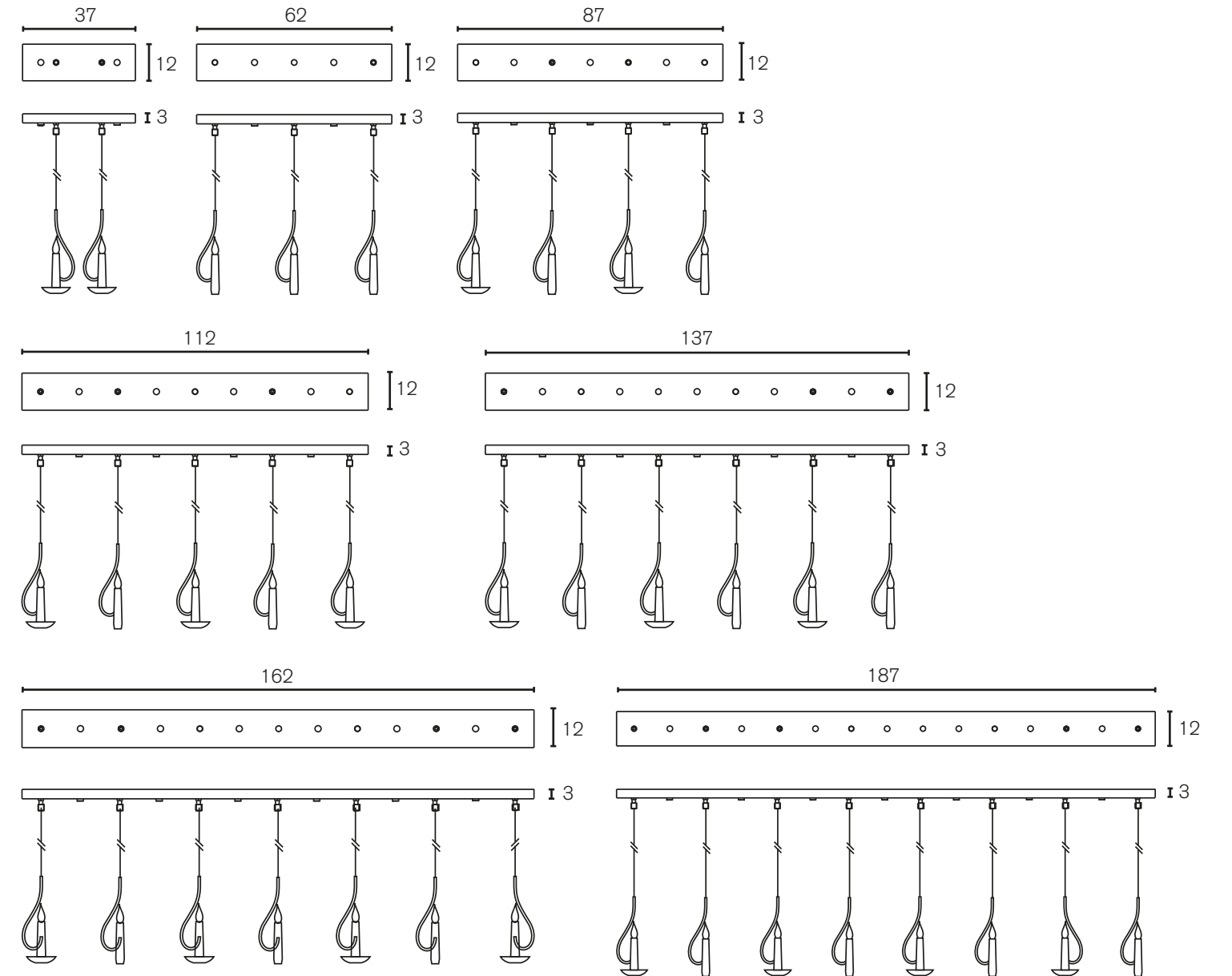

All lamps are supplied with 1,7 meter chain, 2 meter electrical cable and a ceiling shade. White finish on request.

Ceiling Cover for Crown

| Art.nr. | Dimensions CM |
|-----------|---------------------------------|
| FC3CHPOT | Ø 50cm, 2,6 kg, stainless steel |
| FC6CHPOT | Ø 60cm, 3,0 kg, stainless steel |
| FC8CHPOT | Ø 80cm, 3,3 kg, stainless steel |
| FC12CHPOT | Ø 90cm, 3,7 kg, stainless steel |
| FC16CHPOT | Ø 95cm, 3,9 kg, stainless steel |

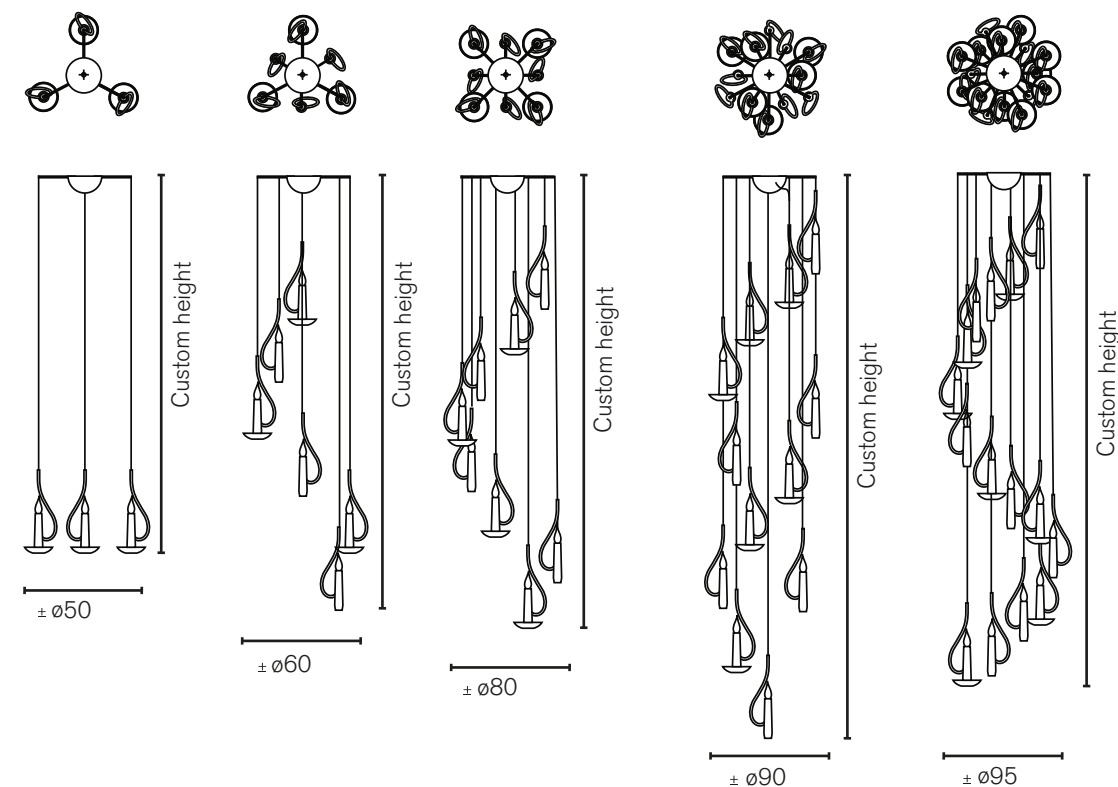

Wall lamp

| Art.nr. | Dimensions CM |
|-----------|---|
| FCW36WM | Width 12cm, Height 36cm, Depth 8cm, 1x E14, 3,0 kg, white matt finish |
| FCW36ST | Width 12cm, Height 36cm, Depth 8cm, 1x E14, 3,0 kg, stainless steel |
| FCDLW36WM | Width 16cm, Height 36cm, Depth 20cm, 1x E14, 4,0 kg, 1 spot, downlight, white matt finish |
| FCDLW36ST | Width 16cm, Height 36cm, Depth 20cm, 1x E14, 4,0 kg, 1 spot, downlight, stainless steel |

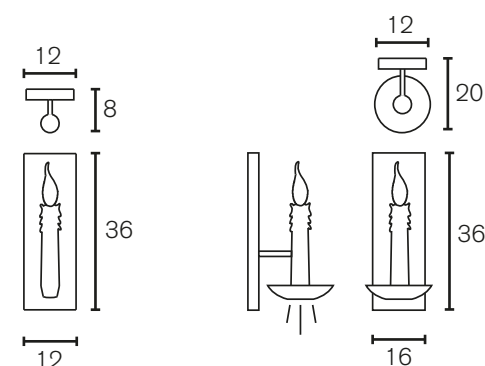

Collection Love You Love You Not 2007

Chandelier Conical

| Art.nr. | Dimensions CM |
|----------|--|
| LYCC60BL | Ø 60cm, Height 70cm, Length chain 170cm, 10x E14, 22,0 kg, black finish |
| LYCC60W | Ø 60cm, Height 70cm, Length chain 170cm, 10x E14, 22,0 kg, white finish |
| LYCC60N | Ø 60cm, Height 70cm, Length chain 170cm, 10x E14, 22,0 kg, nickel finish |
| LYCC70BL | Ø 70cm, Height 80cm, Length chain 170cm, 12x E14, 28,0 kg, black finish |
| LYCC70W | Ø 70cm, Height 80cm, Length chain 170cm, 12x E14, 28,0 kg, white finish |
| LYCC70N | Ø 70cm, Height 80cm, Length chain 170cm, 12x E14, 28,0 kg, nickel finish |

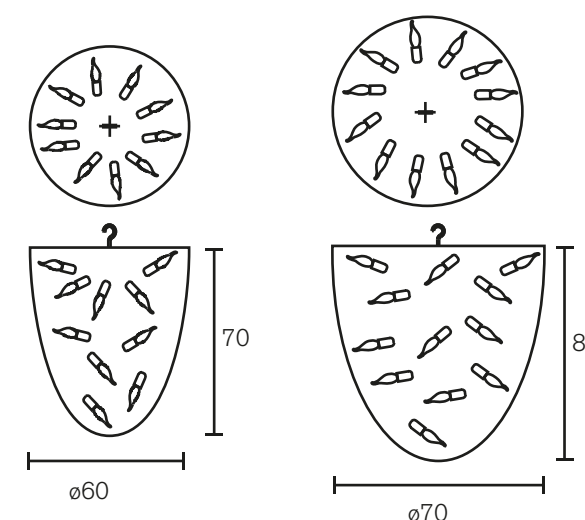

Chandelier Oval

| Art.nr. | Dimensions CM |
|-----------|--|
| LYOC60BL | Length 120cm, Width 60cm, Height 65cm, Length chain 170cm, 16x E14, 25,0 kg, black finish |
| LYOC60W | Length 120cm, Width 60cm, Height 65cm, Length chain 170cm, 16x E14, 25,0 kg, white finish |
| LYOC60N | Length 120cm, Width 60cm, Height 65cm, Length chain 170cm, 16x E14, 25,0 kg, nickel finish |
| LYOC70BL | Length 140cm, Width 70cm, Height 65cm, Length chain 170cm, 16x E14, 26,0 kg, black finish |
| LYOC70W | Length 140cm, Width 70cm, Height 65cm, Length chain 170cm, 16x E14, 26,0 kg, white finish |
| LYOC70N | Length 140cm, Width 70cm, Height 65cm, Length chain 170cm, 16x E14, 26,0 kg, nickel finish |
| LYOC80BL | Length 160cm, Width 70cm, Height 65cm, Length chain 170cm, 18x E14, 41,0 kg, black finish |
| LYOC80W | Length 160cm, Width 70cm, Height 65cm, Length chain 170cm, 18x E14, 41,0 kg, white finish |
| LYOC80N | Length 160cm, Width 70cm, Height 65cm, Length chain 170cm, 18x E14, 41,0 kg, nickel finish |
| LYOC100BL | Length 200cm, Width 70cm, Height 65cm, Length chain 170cm, 24x E14, 65,0 kg, black finish |
| LYOC100W | Length 200cm, Width 70cm, Height 65cm, Length chain 170cm, 24x E14, 65,0 kg, white finish |
| LYOC100N | Length 200cm, Width 70cm, Height 65cm, Length chain 170cm, 24x E14, 65,0 kg, nickel finish |

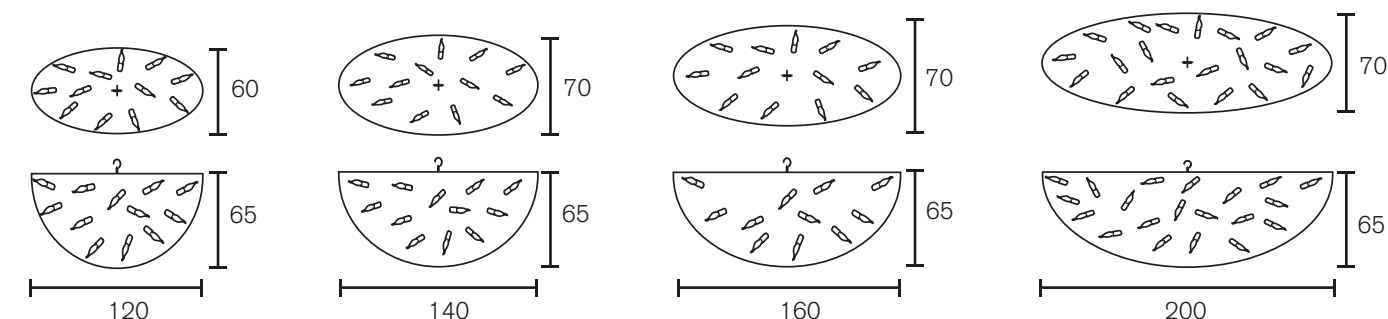

All chandeliers are supplied with 1,7 meter chain, 2 meter electrical cable and a ceiling shade. All floor- and table lamps are supplied with a dimmer.

Chandelier Round

| Art.nr. | Dimensions CM |
|----------|---|
| LYC80BL | Ø 80cm, Height 45cm, Length chain 170cm, 12x E14, 22,0 kg, black finish |
| LYC80W | Ø 80cm, Height 45cm, Length chain 170cm, 12x E14, 22,0 kg, white finish |
| LYC80N | Ø 80cm, Height 45cm, Length chain 170cm, 12x E14, 22,0 kg, nickel finish |
| LYC100BL | Ø 100cm, Height 55cm, Length chain 170cm, 14x E14, 35,0 kg, black finish |
| LYC100W | Ø 100cm, Height 55cm, Length chain 170cm, 14x E14, 35,0 kg, white finish |
| LYC100N | Ø 100cm, Height 55cm, Length chain 170cm, 14x E14, 35,0 kg, nickel finish |
| LYC120BL | Ø 120cm, Height 70cm, Length chain 170cm, 16x E14, 55,0 kg, black finish |
| LYC120W | Ø 120cm, Height 70cm, Length chain 170cm, 16x E14, 55,0 kg, white finish |
| LYC120N | Ø 120cm, Height 70cm, Length chain 170cm, 16x E14, 55,0 kg, nickel finish |
| LYC140BL | Ø 140cm, Height 70cm, Length chain 170cm, 18x E14, 60,0 kg, black finish |
| LYC140W | Ø 140cm, Height 70cm, Length chain 170cm, 18x E14, 60,0 kg, white finish |
| LYC140N | Ø 140cm, Height 70cm, Length chain 170cm, 18x E14, 60,0 kg, nickel finish |

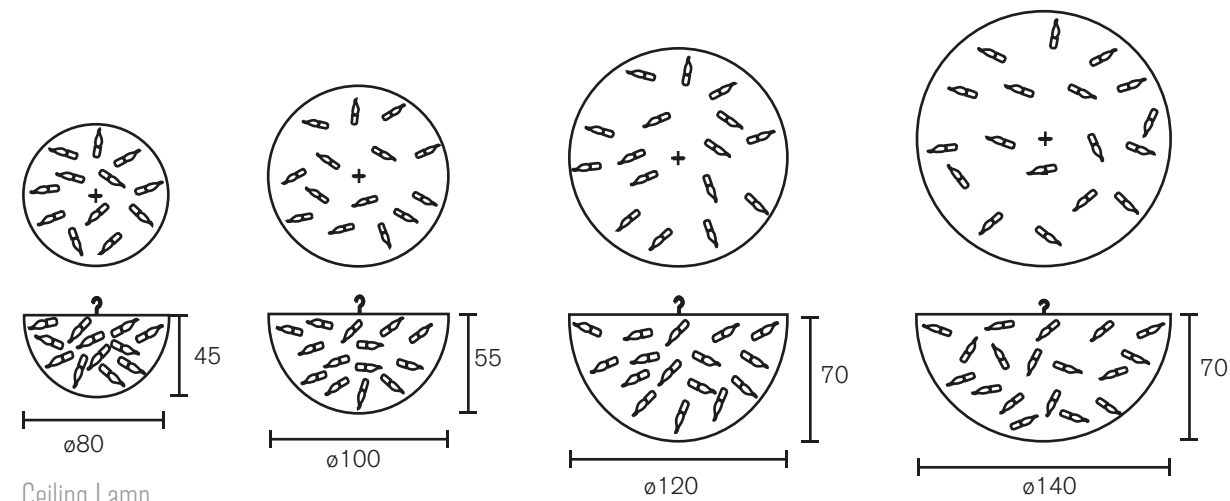

Ceiling Lamp

| Art.nr. | Dimensions CM |
|----------|---|
| LYP60BL | Ø 60cm, Height 30cm, 6x E14, 8,0 kg, black finish |
| LYP60W | Ø 60cm, Height 30cm, 6x E14, 8,0 kg, white finish |
| LYP60N | Ø 60cm, Height 30cm, 6x E14, 8,0 kg, nickel finish |
| LYP80BL | Ø 80cm, Height 30cm, 8x E14, 13,0 kg, black finish |
| LYP80W | Ø 80cm, Height 30cm, 8x E14, 13,0 kg, white finish |
| LYP80N | Ø 80cm, Height 30cm, 8x E14, 13,0 kg, nickel finish |
| LYP100BL | Ø 100cm, Height 30cm, 10x E14, 20,0 kg, black finish |
| LYP100W | Ø 100cm, Height 30cm, 10x E14, 20,0 kg, white finish |
| LYP100N | Ø 100cm, Height 30cm, 10x E14, 20,0 kg, nickel finish |

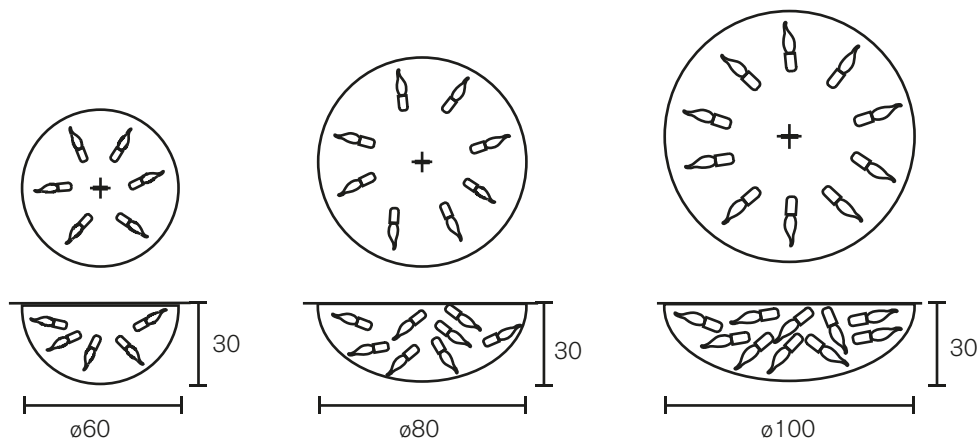

All chandeliers are supplied with 1,7 meter chain, 2 meter electrical cable and a ceiling shade. All floor- and table lamps are supplied with a dimmer.

Hanging Lamp

| Art.nr. | Dimensions CM |
|----------|---|
| LYCB55BL | Ø 55cm, Length steel cable 200cm, 8x E14, 14,0 kg, black finish |
| LYCB55W | Ø 55cm, Length steel cable 200cm, 8x E14, 14,0 kg, white finish |
| LYCB55N | Ø 55cm, Length steel cable 200cm, 8x E14, 14,0 kg, nickel finish |
| LYCB75BL | Ø 75cm, Length steel cable 200cm, 12x E14, 26,0 kg, black finish |
| LYCB75W | Ø 75cm, Length steel cable 200cm, 12x E14, 26,0 kg, white finish |
| LYCB75N | Ø 75cm, Length steel cable 200cm, 12x E14, 26,0 kg, nickel finish |

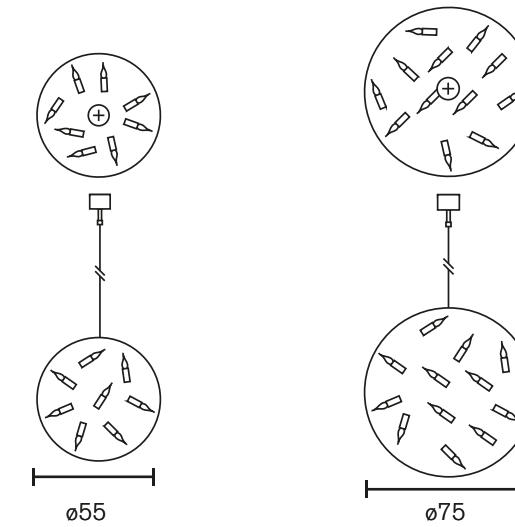

Wall Lamp

| Art.nr. | Dimensions CM |
|-----------|---|
| LYW45BL-L | Width 15cm, Height 45cm, Depth 12cm, 1x E14, 3,5 kg, black finish, left version |
| LYW45BL-R | Width 15cm, Height 45cm, Depth 12cm, 1x E14, 3,5 kg, black finish, right version |
| LYW45W-L | Width 15cm, Height 45cm, Depth 12cm, 1x E14, 3,5 kg, white finish, left version |
| LYW45W-R | Width 15cm, Height 45cm, Depth 12cm, 1x E14, 3,5 kg, white finish, right version |
| LYW45N-L | Width 15cm, Height 45cm, Depth 12cm, 1x E14, 3,5 kg, nickel finish, left version |
| LYW45N-R | Width 15cm, Height 45cm, Depth 12cm, 1x E14, 3,5 kg, nickel finish, right version |

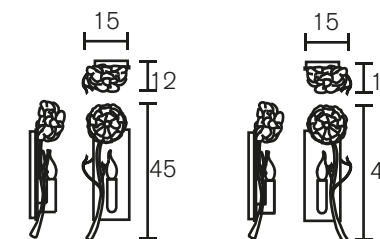

All chandeliers are supplied with 1,7 meter chain, 2 meter electrical cable and a ceiling shade. All floor- and table lamps are supplied with a dimmer.

Collection Lola 2014

Chandelier With Crystals

| Art.nr. | Dimensions CM |
|-------------|---|
| LLCCR100BLM | Ø 90cm, Height 85cm, Length stem 200cm, 12x E14, 25,0 kg, black matt finish |
| LLCCR100WM | Ø 90cm, Height 85cm, Length stem 200cm, 12x E14, 25,0 kg, white matt finish |
| LLCCR100ST | Ø 90cm, Height 85cm, Length stem 200cm, 12x E14, 25,0 kg, stainless steel |

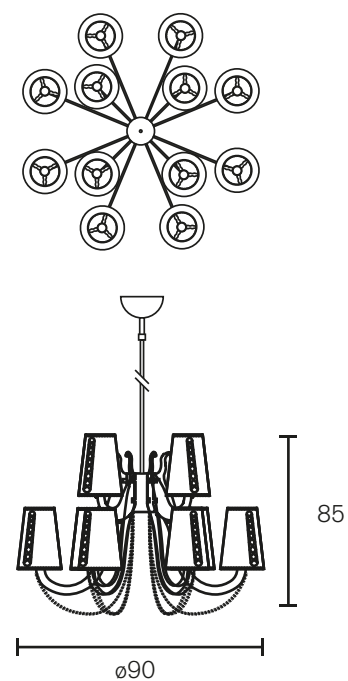

Wall Lamp

| Art.nr. | Dimensions CM |
|----------|--|
| LLW20BLM | Width 17cm, Height 33cm, Depth 20cm, 1x E14, 3,0 kg, black matt finish |
| LLW20WM | Width 17cm, Height 33cm, Depth 20cm, 1x E14, 3,0 kg, white matt finish |
| LLW20ST | Width 17cm, Height 33cm, Depth 20cm, 1x E14, 3,0 kg, stainless steel |

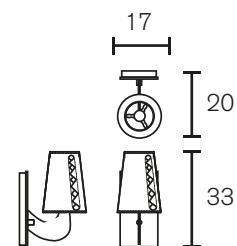

The chandelier is supplied with 2 meter stem, 2 meter electrical cable and a ceiling shade. All crystals are original Swarovski crystals.

Collection Nightwatch 2014

Chandelier Round

| Art.nr. | Dimensions CM |
|----------|--|
| NWH60ST | Ø 60cm, Height 48cm, Length chain 170cm, 6x E14, 8,5 kg, stainless steel |
| NWH75BLM | Ø 75cm, Height 72cm, Length chain 170cm, 12x E14, 15,0 kg, black matt finish |
| NWH75WM | Ø 75cm, Height 72cm, Length chain 170cm, 12x E14, 15,0 kg, white matt finish |
| NWH75ST | Ø 75cm, Height 72cm, Length chain 170cm, 12x E14, 15,0 kg, stainless steel |
| NWH95BLM | Ø 95cm, Height 78cm, Length chain 170cm, 12x E14, 18,0 kg, black matt finish |
| NWH95WM | Ø 95cm, Height 78cm, Length chain 170cm, 12x E14, 18,0 kg, white matt finish |
| NWH95ST | Ø 95cm, Height 78cm, Length chain 170cm, 12x E14, 18,0 kg, stainless steel |
| NWH140ST | Ø 140cm, Height 108cm, Length chain 170cm, 18x E14, 30,0 kg, stainless steel |

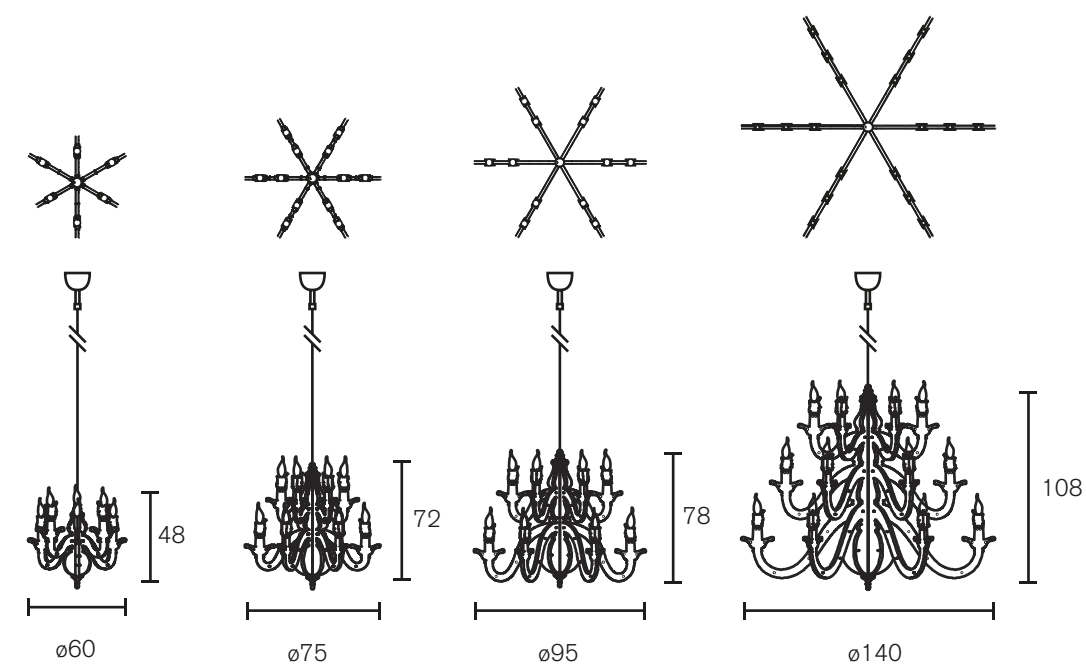

Wall Lamp

| Art.nr. | Dimensions CM |
|---------|--|
| NWW17ST | Width 17cm, Height 31cm, Depth 10cm, 1x E14, 1,0 kg, stainless steel |

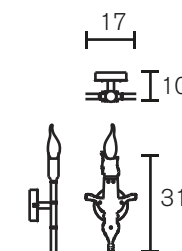

All chandeliers are supplied with 1,7 meter chain, 2 meter electrical cable and a ceiling shade. All floor- and table lamps are supplied with a dimmer.

Collection Candles And Spirits 2003

Chandelier Round

| Art.nr. | Dimensions CM |
|-----------|---|
| CASH90NH | Ø 90cm, Height 70cm, Length stem 200cm, 8x G9, 10,0 kg, nickel finish |
| CASH120NH | Ø 90cm, Height 120cm, Length stem 200cm, 12x G9, 20,0 kg, nickel finish |

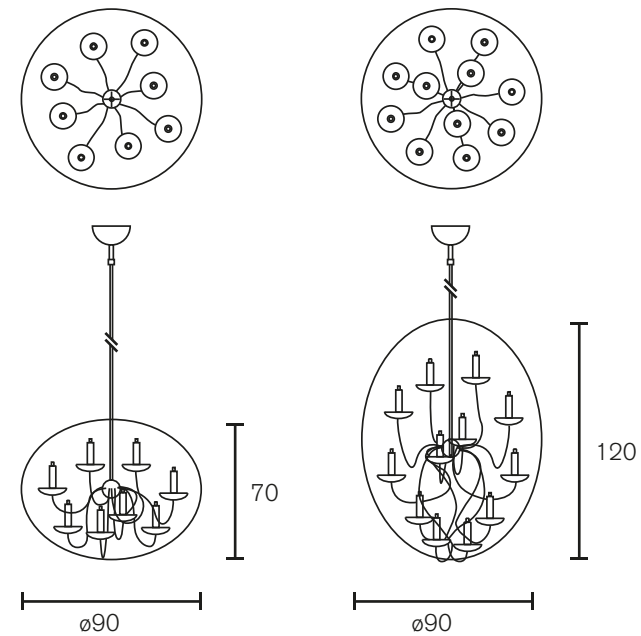

Chandelier Oval

| Art.nr. | Dimensions CM |
|-----------|---|
| CASH070NH | Length 130cm, Width 70cm, Height 60cm, Length stem 200cm, 8x G9, 15,0 kg, nickel finish |

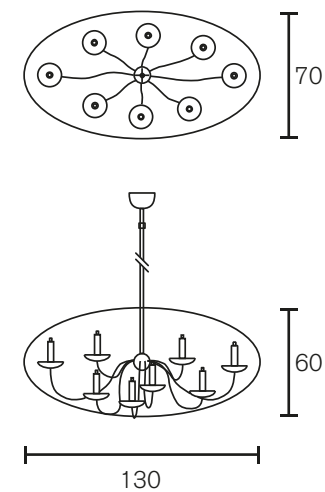

All chandeliers are standard supplied with 2 meter stem, 2 meter electrical cable and a ceiling shade. All crystal are original Swarovski crystals.

Wall Lamp

| Art.nr. | Dimensions CM |
|----------|---|
| CASW40NH | Width 20cm, Height 40cm, Depth 20cm, 1x G9, 1,5 kg, nickel finish |
| CASW60NH | Width 25cm, Height 60cm, Depth 25cm, 1x G9, 1,8 kg, nickel finish |

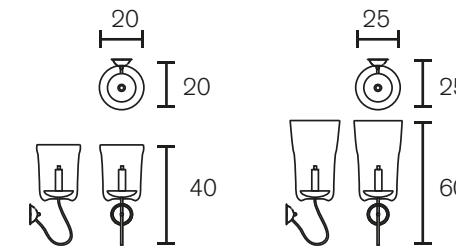

Candles and Spirits Squadra

| Art.nr. | Dimensions CM |
|---------|--|
| 50CASHN | Ø 50cm, Height 80cm, Length steel cable 200cm, 1x E14, 3,5 kg, nickel finish |

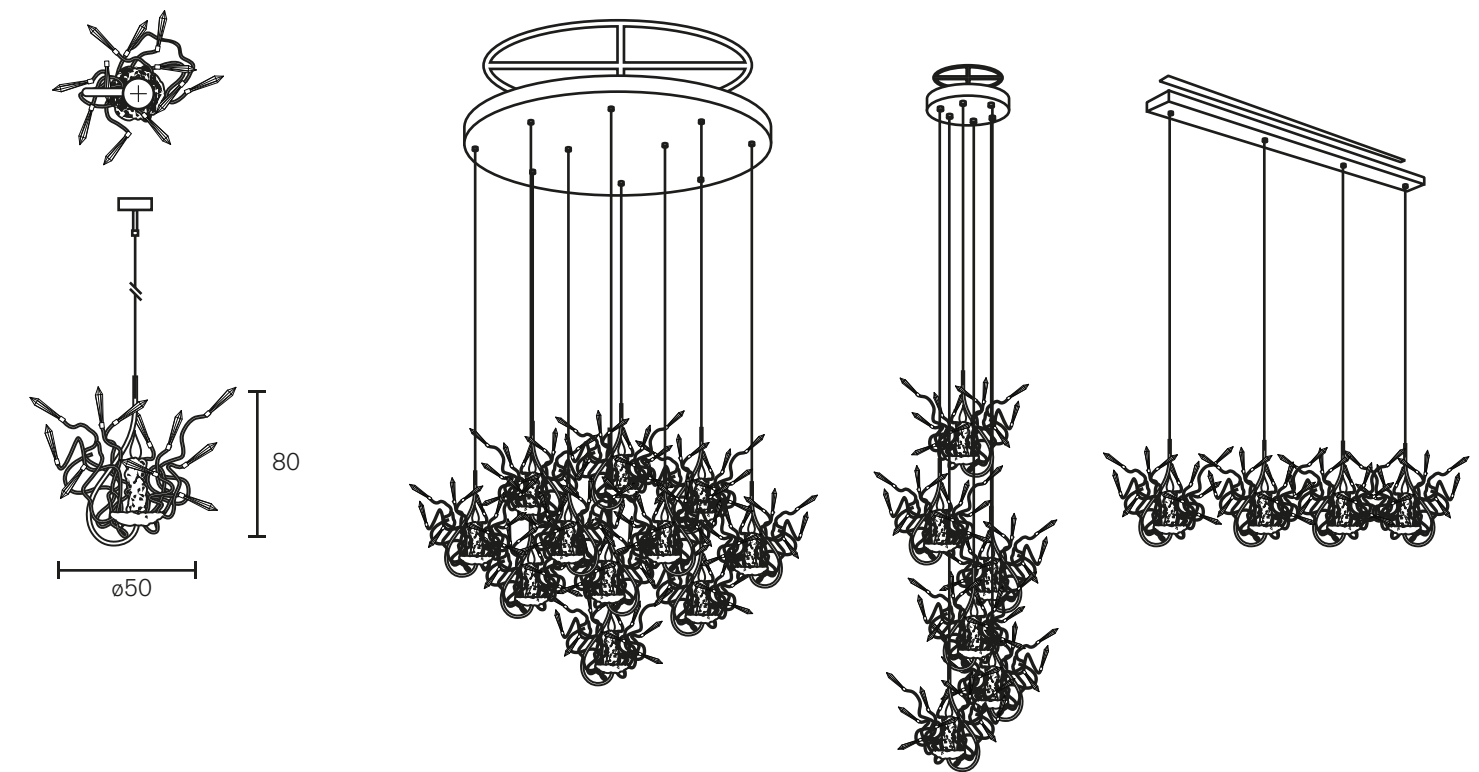

*Order 6-12 pieces: 10% discount *Order 13-18 pieces: 15% discount *Order 19 pieces or more: 20% discount

All chandeliers are supplied with 1,7 meter chain, 2 meter electrical cable and a ceiling shade. All floor- and table lamps are supplied with a dimmer.

Collection Flower Power 2005

Chandelier

| Art.nr. | Dimensions CM |
|----------|---|
| FPC120BL | Ø 120cm, Height 85cm, Length stem 200cm, 20x G9, 52,0 kg, black finish |
| FPC120W | Ø 120cm, Height 85cm, Length stem 200cm, 20x G9, 52,0 kg, white finish |
| FPC120N | Ø 120cm, Height 85cm, Length stem 200cm, 20x G9, 52,0 kg, nickel finish |

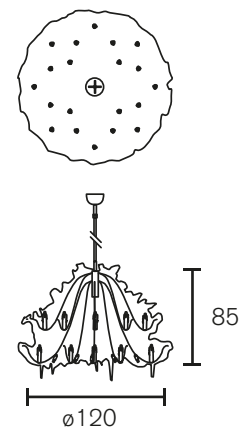

Chandelier Round Upside Down

| Art.nr. | Dimensions CM |
|-------------|---|
| FPCUSD60BL | Ø 60cm, Height 45cm, Length stem 200cm, 10x G9, 15,0 kg, black finish |
| FPCUSD60W | Ø 60cm, Height 45cm, Length stem 200cm, 10x G9, 15,0 kg, white finish |
| FPCUSD60N | Ø 60cm, Height 45cm, Length stem 200cm, 10x G9, 15,0 kg, nickel finish |
| FPCUSD80BL | Ø 80cm, Height 50cm, Length stem 200cm, 12x G9, 26,0 kg, black finish |
| FPCUSD80W | Ø 80cm, Height 50cm, Length stem 200cm, 12x G9, 26,0 kg, white finish |
| FPCUSD80N | Ø 80cm, Height 50cm, Length stem 200cm, 12x G9, 26,0 kg, nickel finish |
| FPCUSD100BL | Ø 100cm, Height 55cm, Length stem 200cm, 15x G9, black finish |
| FPCUSD100W | Ø 100cm, Height 55cm, Length stem 200cm, 15x G9, white finish |
| FPCUSD100N | Ø 100cm, Height 55cm, Length stem 200cm, 15x G9, nickel finish |
| FPCUSD120BL | Ø 120cm, Height 60cm, Length stem 200cm, 18x G9, 49,0 kg, black finish |
| FPCUSD120W | Ø 120cm, Height 60cm, Length stem 200cm, 18x G9, 49,0 kg, white finish |
| FPCUSD120N | Ø 120cm, Height 60cm, Length stem 200cm, 18x G9, 49,0 kg, nickel finish |

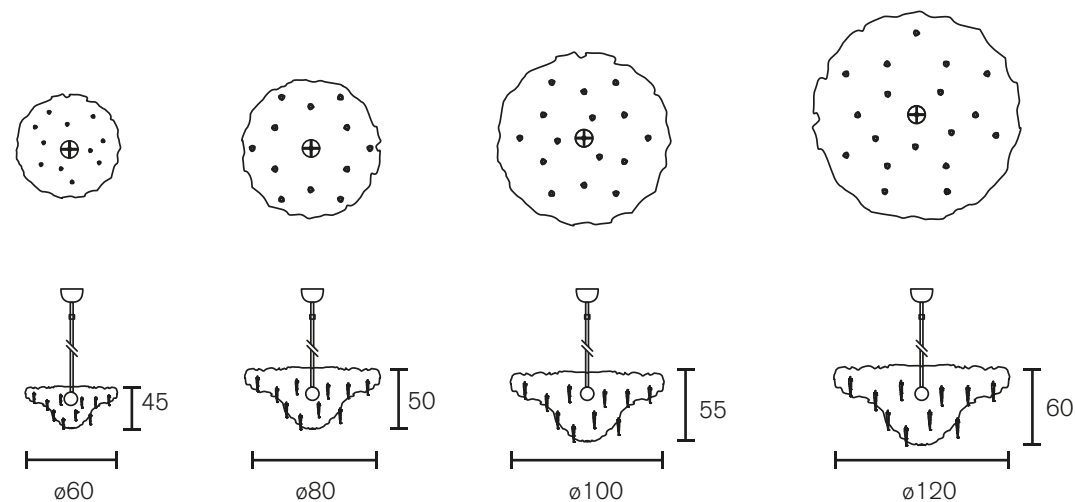

All hanging lamps and chandeliers are supplied with 2 meter stem, 2 meter electrical cable and a ceiling shade.

Chandelier Oval

| Art.nr. | Dimensions CM |
|-----------|--|
| FPHO115BL | Length 115cm, Width 65cm, Height 40cm, Length stem 200cm, 12x G9, 28,0 kg, black finish |
| FPHO115W | Length 115cm, Width 65cm, Height 40cm, Length stem 200cm, 12x G9, 28,0 kg, white finish |
| FPHO115N | Length 115cm, Width 65cm, Height 40cm, Length stem 200cm, 12x G9, 28,0 kg, nickel finish |
| FPHO135BL | Length 135cm, Width 65cm, Height 45cm, Length stem 200cm, 12x G9, 35,0 kg, black finish |
| FPHO135W | Length 135cm, Width 65cm, Height 45cm, Length stem 200cm, 12x G9, 35,0 kg, white finish |
| FPHO135N | Length 135cm, Width 65cm, Height 45cm, Length stem 200cm, 12x G9, 35,0 kg, nickel finish |
| FPHO155BL | Length 155cm, Width 65cm, Height 45cm, Length stem 200cm, 12x G9, 40,0 kg, black finish |
| FPHO155W | Length 155cm, Width 65cm, Height 45cm, Length stem 200cm, 12x G9, 40,0 kg, white finish |
| FPHO155N | Length 155cm, Width 65cm, Height 45cm, Length stem 200cm, 12x G9, 40,0 kg, nickel finish |

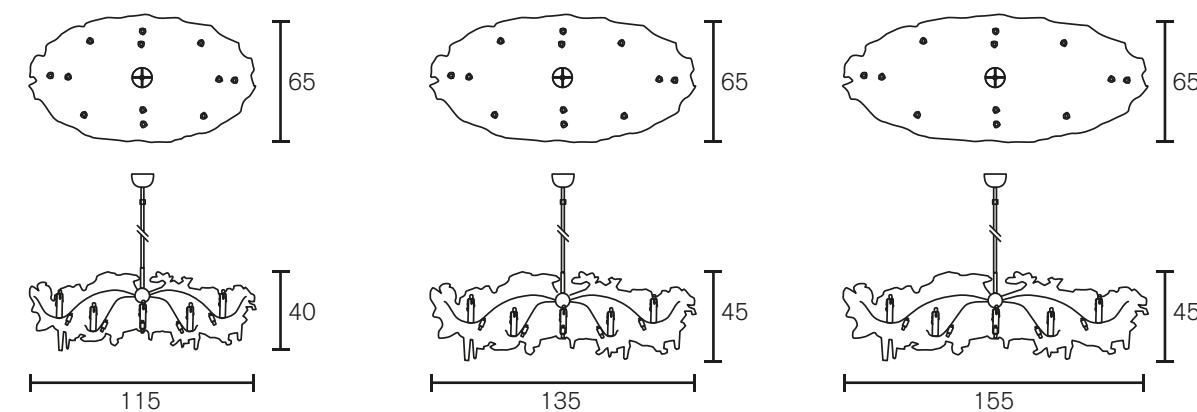

Hanging Lamp Round

| Art.nr. | Dimensions CM |
|-----------|---|
| FPHL80BL | Ø 80cm, Height 40cm, Length stem 200cm, 12x G9, 18,0 kg, black finish |
| FPHL80W | Ø 80cm, Height 40cm, Length stem 200cm, 12x G9, 18,0 kg, white finish |
| FPHL80N | Ø 80cm, Height 40cm, Length stem 200cm, 12x G9, 18,0 kg, nickel finish |
| FPHL100BL | Ø 100cm, Height 50cm, Length stem 200cm, 12x G9, 24,0 kg, black finish |
| FPHL100W | Ø 100cm, Height 50cm, Length stem 200cm, 12x G9, 24,0 kg, white finish |
| FPHL100N | Ø 100cm, Height 50cm, Length stem 200cm, 12x G9, 24,0 kg, nickel finish |
| FPHL120BL | Ø 120cm, Height 50cm, Length stem 200cm, 12x G9, 40,0 kg, black finish |
| FPHL120W | Ø 120cm, Height 50cm, Length stem 200cm, 12x G9, 40,0 kg, white finish |
| FPHL120N | Ø 120cm, Height 50cm, Length stem 200cm, 12x G9, 40,0 kg, nickel finish |

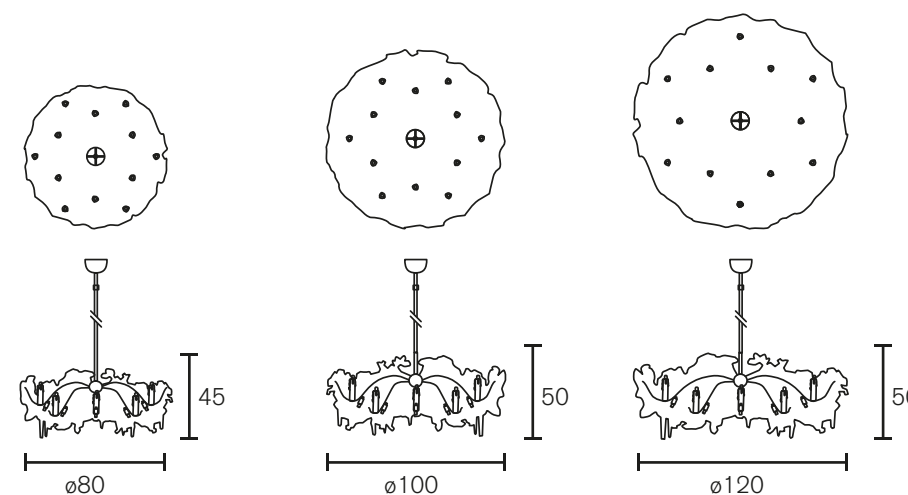

All hanging lamps and chandeliers are supplied with 2 meter stem, 2 meter electrical cable and a ceiling shade.

Ceiling Lamp Round

| Art.nr. | Dimensions CM |
|----------|--|
| FPP60BL | Ø 60cm, Height 30cm, 9x G9, 10,0 kg, black finish |
| FPP60W | Ø 60cm, Height 30cm, 9x G9, 10,0 kg, white finish |
| FPP60N | Ø 60cm, Height 30cm, 9x G9, 10,0 kg, nickel finish |
| FPP80BL | Ø 80cm, Height 35cm, 12x G9, 25,0 kg, black finish |
| FPP80W | Ø 80cm, Height 35cm, 12x G9, 25,0 kg, white finish |
| FPP80N | Ø 80cm, Height 35cm, 12x G9, 25,0 kg, nickel finish |
| FPP100BL | Ø 100cm, Height 40cm, 12x G9, 31,5 kg, black finish |
| FPP100W | Ø 100cm, Height 40cm, 12x G9, 31,5 kg, white finish |
| FPP100N | Ø 100cm, Height 40cm, 12x G9, 31,5 kg, nickel finish |
| FPP120BL | Ø 120cm, Height 45cm, 15x G9, 40,0 kg, black finish |
| FPP120W | Ø 120cm, Height 45cm, 15x G9, 40,0 kg, white finish |
| FPP120N | Ø 120cm, Height 45cm, 15x G9, 40,0 kg, nickel finish |

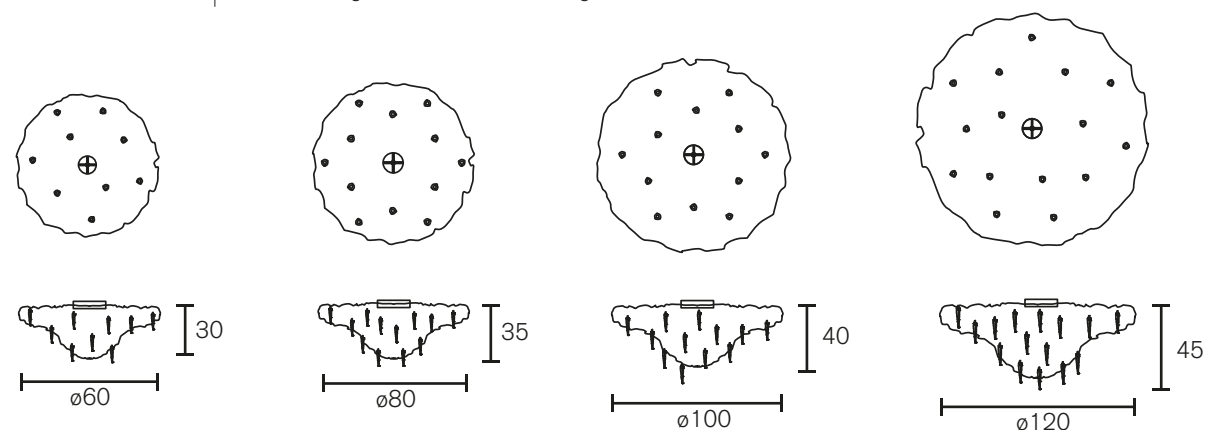

Wall Lamp

| Art.nr. | Dimensions CM |
|-----------|--|
| FPW30BL-L | Length 30cm, Height 40cm, Depth 14cm, 1x E14, 3,0 kg, black finish, left version |
| FPW30BL-R | Length 30cm, Height 40cm, Depth 14cm, 1x E14, 3,0 kg, black finish, right version |
| FPW30W-L | Length 30cm, Height 40cm, Depth 14cm, 1x E14, 3,0 kg, white finish, left version |
| FPW30W-R | Length 30cm, Height 40cm, Depth 14cm, 1x E14, 3,0 kg, white finish, right version |
| FPW30N-L | Length 30cm, Height 40cm, Depth 14cm, 1x E14, 3,0 kg, nickel finish, left version |
| FPW30N-R | Length 30cm, Height 40cm, Depth 14cm, 1x E14, 3,0 kg, nickel finish, right version |

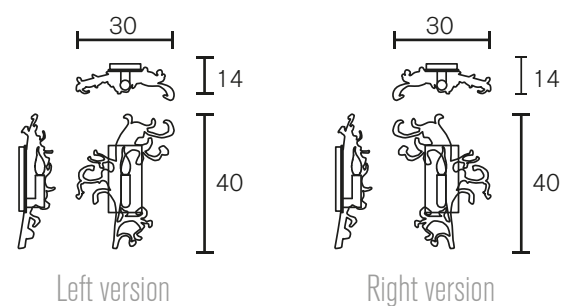

All hanging lamps and chandeliers are supplied with 2 meter stem, 2 meter electrical cable and a ceiling shade.

Collection Icy Lady 2005

Hanging lamp Round

| Art.nr. | Dimensions CM |
|----------|---|
| ILC80BL | Ø 80cm, Height 35cm, Length stem 200cm, 12x G9, 23,0 kg, black finish |
| ILC80W | Ø 80cm, Height 35cm, Length stem 200cm, 12x G9, 23,0 kg, white finish |
| ILC80N | Ø 80cm, Height 35cm, Length stem 200cm, 12x G9, 23,0 kg, nickel finish |
| ILC100BL | Ø 100cm, Height 45cm, Length stem 200cm, 12x G9, 34,0 kg, black finish |
| ILC100W | Ø 100cm, Height 45cm, Length stem 200cm, 12x G9, 34,0 kg, white finish |
| ILC100N | Ø 100cm, Height 45cm, Length stem 200cm, 12x G9, 34,0 kg, nickel finish |
| ILC120BL | Ø 120cm, Height 55cm, Length stem 200cm, 12x G9, 52,0 kg, black finish |
| ILC120W | Ø 120cm, Height 55cm, Length stem 200cm, 12x G9, 52,0 kg, white finish |
| ILC120N | Ø 120cm, Height 55cm, Length stem 200cm, 12x G9, 52,0 kg, nickel finish |

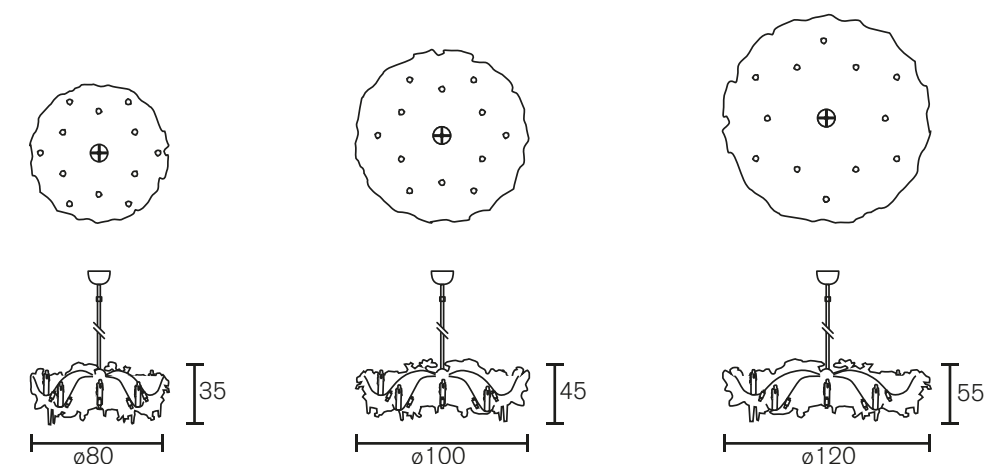

All hanging lamps and chandeliers are supplied with 2 meter stem, 2 meter electrical cable and a ceiling shade. All crystal are original Swarovski crystals.

Chandelier Round Upside-down

| Art.nr. | Dimensions CM |
|-------------|---|
| ILCUSD60BL | Ø 60cm, Height 30cm, Length stem 200cm, 10x G9, 28,0 kg, black finish |
| ILCUSD60W | Ø 60cm, Height 30cm, Length stem 200cm, 10x G9, 28,0 kg, white finish |
| ILCUSD60N | Ø 60cm, Height 30cm, Length stem 200cm, 10x G9, 28,0 kg, nickel finish |
| ILCUSD80BL | Ø 80cm, Height 37cm, Length stem 200cm, 12x G9, 29,5 kg, black finish |
| ILCUSD80W | Ø 80cm, Height 37cm, Length stem 200cm, 12x G9, 29,5 kg, white finish |
| ILCUSD80N | Ø 80cm, Height 37cm, Length stem 200cm, 12x G9, 29,5 kg, nickel finish |
| ILCUSD100BL | Ø 100cm, Height 45cm, Length stem 200cm, 15x G9, 36,0 kg, black finish |
| ILCUSD100W | Ø 100cm, Height 45cm, Length stem 200cm, 15x G9, 36,0 kg, white finish |
| ILCUSD100N | Ø 100cm, Height 45cm, Length stem 200cm, 15x G9, 36,0 kg, nickel finish |
| ILCUSD120BL | Ø 120cm, Height 55cm, Length stem 200cm, 18x G9, 46,0 kg, black finish |
| ILCUSD120W | Ø 120cm, Height 55cm, Length stem 200cm, 18x G9, 46,0 kg, white finish |
| ILCUSD120N | Ø 120cm, Height 55cm, Length stem 200cm, 18x G9, 46,0 kg, nickel finish |

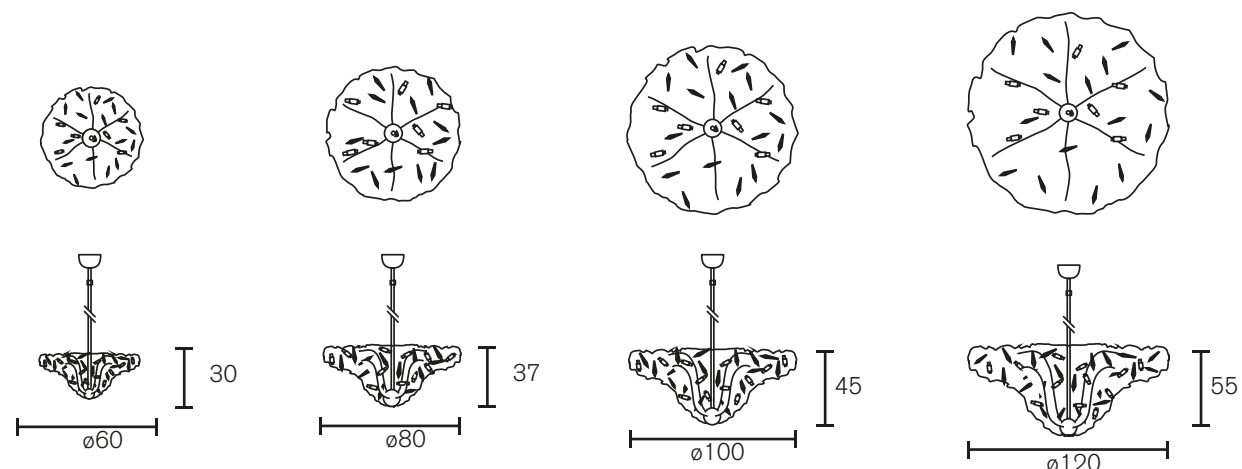

Chandelier Oval

| Art.nr. | Dimensions CM |
|-----------|--|
| ILCO115BL | Length 115cm, Width 65cm, Height 40cm, Length stem 200cm, 12x G9, 27,0 kg, black finish |
| ILCO115W | Length 115cm, Width 65cm, Height 40cm, Length stem 200cm, 12x G9, 27,0 kg, white finish |
| ILCO115N | Length 115cm, Width 65cm, Height 40cm, Length stem 200cm, 12x G9, 27,0 kg, nickel finish |
| ILCO135BL | Length 135cm, Width 65cm, Height 45cm, Length stem 200cm, 12x G9, 30,0 kg, black finish |
| ILCO135W | Length 135cm, Width 65cm, Height 45cm, Length stem 200cm, 12x G9, 30,0 kg, white finish |
| ILCO135N | Length 135cm, Width 65cm, Height 45cm, Length stem 200cm, 12x G9, 30,0 kg, nickel finish |
| ILCO155BL | Length 155cm, Width 65cm, Height 45cm, Length stem 200cm, 12x G9, 40,0 kg, black finish |
| ILCO155W | Length 155cm, Width 65cm, Height 45cm, Length stem 200cm, 12x G9, 40,0 kg, white finish |
| ILCO155N | Length 155cm, Width 65cm, Height 45cm, Length stem 200cm, 12x G9, 40,0 kg, nickel finish |

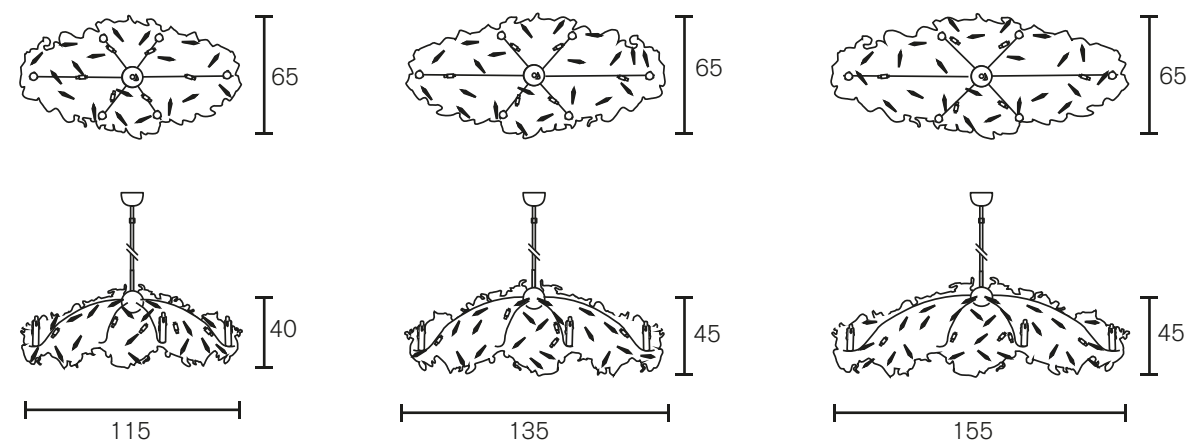

All hanging lamps and chandeliers are supplied with 2 meter stem, 2 meter electrical cable and a ceiling shade. All crystal are original Swarovski crystals.

Wall Lamp

| Art.nr. | Dimensions CM |
|-----------|--|
| ILW30BL-L | Length 30cm, Height 40cm, Depth 14cm, 1x E14, 3,0 kg, black finish, left version |
| ILW30BL-R | Length 30cm, Height 40cm, Depth 14cm, 1x E14, 3,0 kg, black finish, right version |
| ILW30W-L | Length 30cm, Height 40cm, Depth 14cm, 1x E14, 3,0 kg, white finish, left version |
| ILW30W-R | Length 30cm, Height 40cm, Depth 14cm, 1x E14, 3,0 kg, white finish, right version |
| ILW30N-L | Length 30cm, Height 40cm, Depth 14cm, 1x E14, 3,0 kg, nickel finish, left version |
| ILW30N-R | Length 30cm, Height 40cm, Depth 14cm, 1x E14, 3,0 kg, nickel finish, right version |

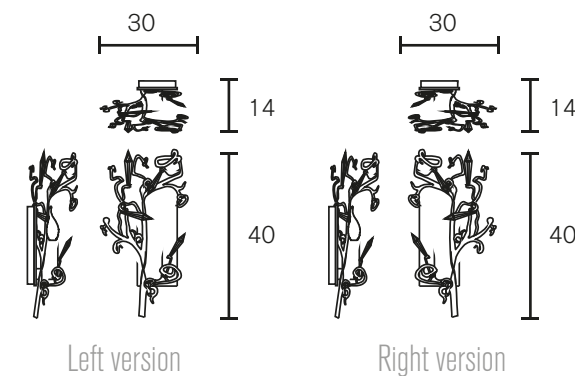

Ceiling Lamp Round

| Art.nr. | Dimensions CM |
|----------|--|
| ILP60BL | Ø 60cm, Height 30cm, 10x G9, 13,0 kg, black finish |
| ILP60W | Ø 60cm, Height 30cm, 10x G9, 13,0 kg, white finish |
| ILP60N | Ø 60cm, Height 30cm, 10x G9, 13,0 kg, nickel finish |
| ILP80BL | Ø 80cm, Height 35cm, 12x G9, 18,0 kg, black finish |
| ILP80W | Ø 80cm, Height 35cm, 12x G9, 18,0 kg, white finish |
| ILP80N | Ø 80cm, Height 35cm, 12x G9, 18,0 kg, nickel finish |
| ILP100BL | Ø 100cm, Height 40cm, 12x G9, 26,0 kg, black finish |
| ILP100W | Ø 100cm, Height 40cm, 12x G9, 26,0 kg, white finish |
| ILP100N | Ø 100cm, Height 40cm, 12x G9, 26,0 kg, nickel finish |
| ILP120BL | Ø 120cm, Height 45cm, 15x G9, 35,0 kg, black finish |
| ILP120W | Ø 120cm, Height 45cm, 15x G9, 35,0 kg, white finish |
| ILP120N | Ø 120cm, Height 45cm, 15x G9, 35,0 kg, nickel finish |

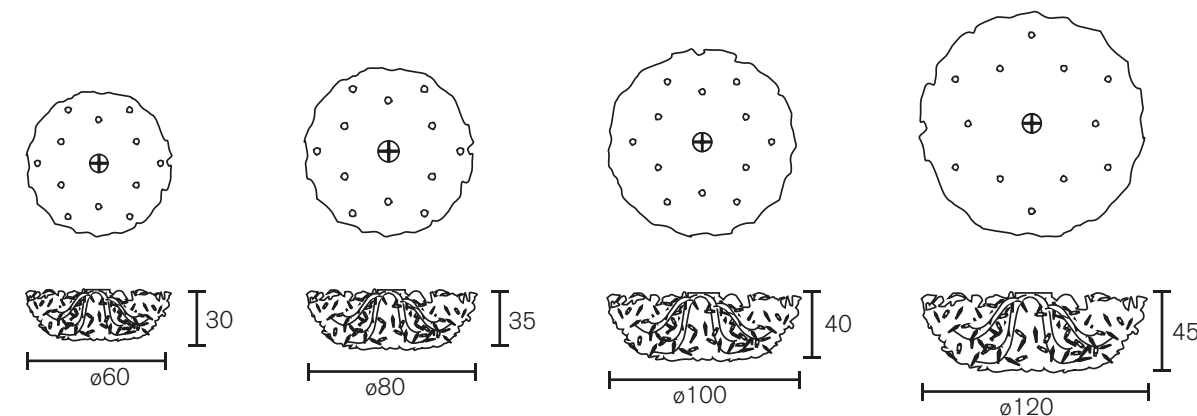

All hanging lamps and chandeliers are supplied with 2 meter stem, 2 meter electrical cable and a ceiling shade. All crystal are original Swarovski crystals.

Collection Broom 2001

Hanging Lamp

| Art.nr. | Dimensions CM |
|---------|---|
| BC103ST | Length 103cm, Width 18cm, Height 25cm, Length steel cable 200cm, 5x E14, 18,0 kg, stainless steel |
| BC126ST | Length 126cm, Width 18cm, Height 25cm, Length steel cable 200cm, 6x E14, 22,0 kg, stainless steel |

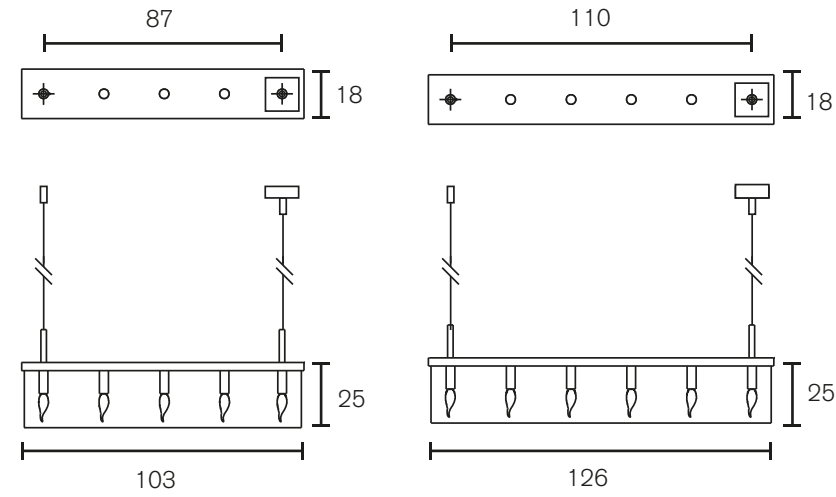

Floor Lamp

| Art.nr. | Dimensions CM |
|---------|---|
| BF195ST | Length 22cm, Width 22cm, Height 195cm, 1x E27, 32,0 kg, stainless steel |

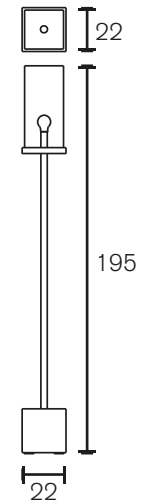

Wall Lamp

| Art.nr. | Dimensions CM |
|---------|--|
| BW13ST | Width 13cm, Height 32cm, Depth 17cm, 1x E14, 3,0 kg, stainless steel |

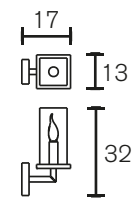

All hanging lamps are supplied with 2 meter steel- and electrical cable and 2 ceiling shades. Long ceiling shade with two steel cable connections available on request.

Collection Rhapsody In Blue 2000

Hanging Lamp

| Art.nr. | Dimensions CM |
|---------|---|
| RH100ST | Length 100cm, Width 20cm, Height 25cm, Length steel cable 200cm, 4x E27, 25,0 kg, stainless steel |
| RH125ST | Length 125cm, Width 20cm, Height 25cm, Length steel cable 200cm, 5x E27, 30,0 kg, stainless steel |
| RH150ST | Length 150cm, Width 20cm, Height 25cm, Length steel cable 200cm, 6x E27, 33,0 kg, stainless steel |
| RH175ST | Length 175cm, Width 20cm, Height 25cm, Length steel cable 200cm, 6x E27, 35,0 kg, stainless steel |
| RH200ST | Length 200cm, Width 20cm, Height 25cm, Length steel cable 200cm, 8x E27, 50,0 kg, stainless steel |

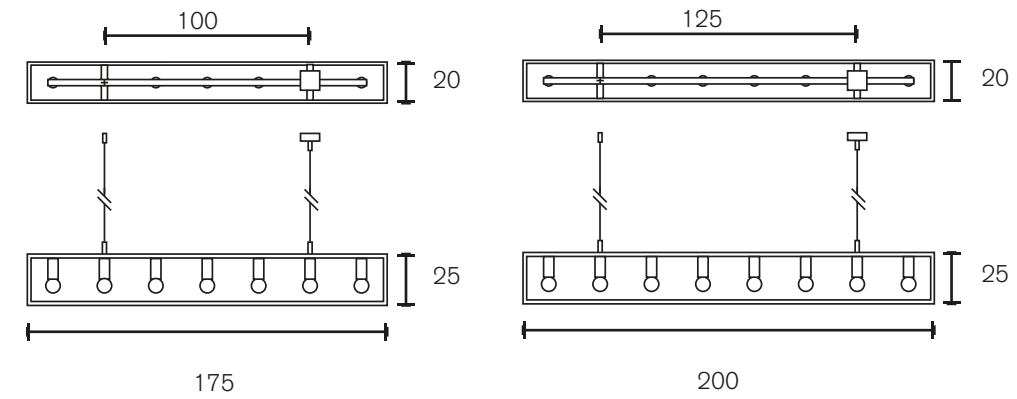
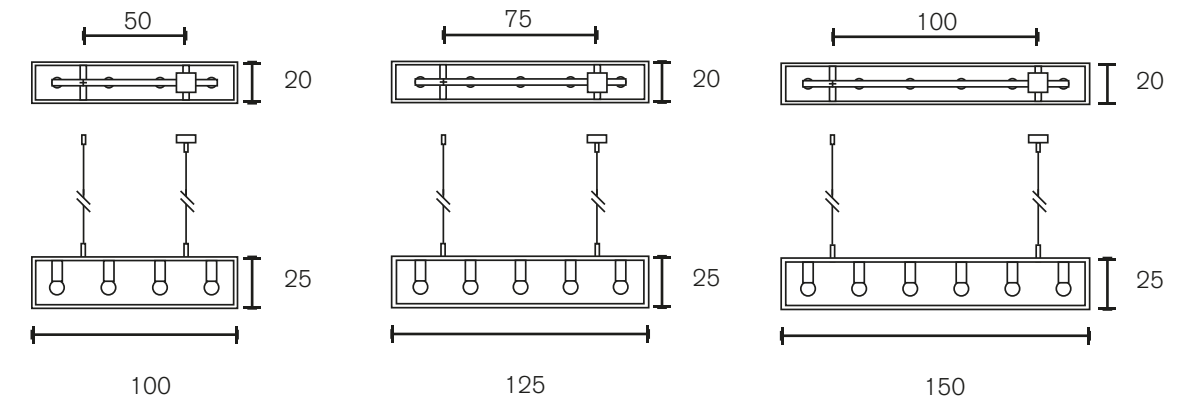

All hanging lamps are supplied with 2 meter steel- and electrical cable and 2 ceiling shades. Long ceiling shade with two steel cable connections available on request.

Collection Crystal Waters 1999

Hanging Lamp

| Art.nr. | Dimensions CM |
|---------|---|
| CWH60NH | Ø 60cm, Height 90cm, Length steel cable 200cm, 16x G9, 12,0 kg, nickel finish |

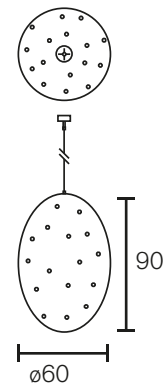

Hanging Lamp Hood

| Art.nr. | Dimensions CM |
|----------|--|
| CWS85NH | Ø 85cm, Height 40cm, Length steel cable 200cm, 18x G9, 18,0 kg, nickel finish |
| CWS105NH | Ø 105cm, Height 50cm, Length steel cable 200cm, 22x G9, 27,0 kg, nickel finish |
| CWS135NH | Ø 135cm, Height 65cm, Length steel cable 200cm, 24x G9, 42,0 kg, nickel finish |
| CWS155NH | Ø 155cm, Height 75cm, Length steel cable 200cm, 26x G9, 55,0 kg, nickel finish |

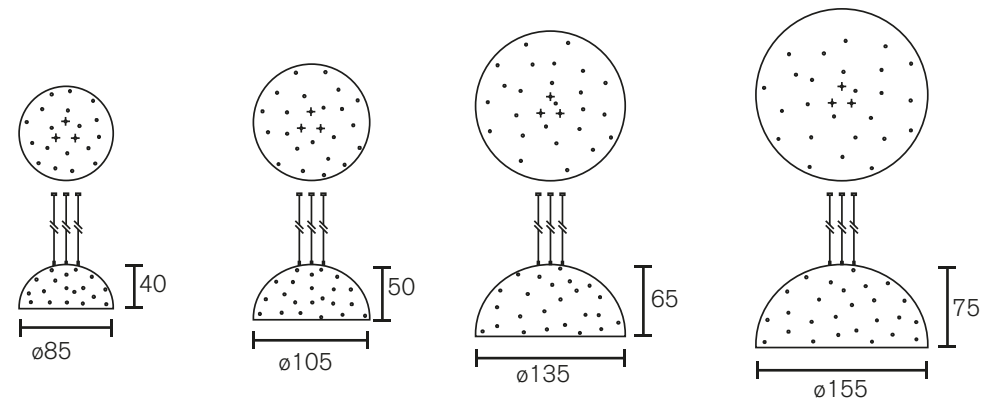

Hanging Lamp Ufo

| Art.nr. | Dimensions CM |
|----------|--|
| CWH59NH | Ø 60cm, Height 30cm, Length steel cable 200cm, 12x G9, 7,0 kg, nickel finish |
| CWH80NH | Ø 80cm, Height 30cm, Length steel cable 200cm, 16x G9, 10,0 kg, nickel finish |
| CWH100NH | Ø 100cm, Height 30cm, Length steel cable 200cm, 20x G9, 13,0 kg, nickel finish |

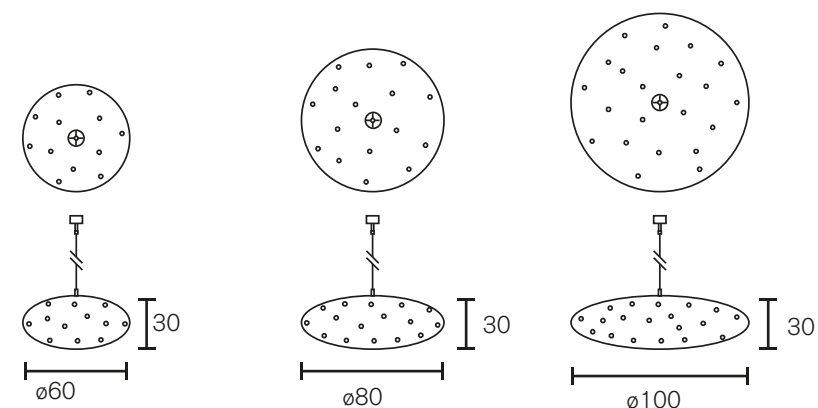

All hanging lamps are supplied with 2 meter electrical cable, 2 meter steel cable and a ceiling shade. All floor lamps are supplied with a dimmer.

Hanging Lamp Cigar

| Art.nr. | Dimensions CM |
|----------|---|
| CWS100NH | Length 100cm, Width 42cm, Height 28cm, Length steel cable 200cm, 12x G9, 6,0 kg, nickel finish |
| CWS130NH | Length 130cm, Width 42cm, Height 35cm, Length steel cable 200cm, 16x G9, 8,0 kg, nickel finish |
| CWS160NH | Length 160cm, Width 45cm, Height 35cm, Length steel cable 200cm, 22x G9, 12,0 kg, nickel finish |
| CWS200NH | Length 200cm, Width 45cm, Height 35cm, Length steel cable 200cm, 26x G9, 15,0 kg, nickel finish |

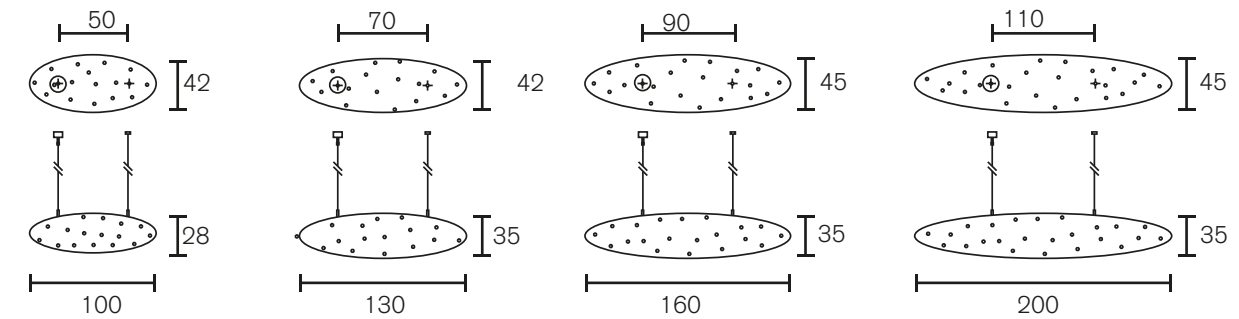

Hanging Lamp Shade

| Art.nr. | Dimensions CM |
|-------------|---|
| CWSHADE60NH | Ø 60cm, Height 70cm, Length steel cable 200cm, 16x G9, 25,0 kg, nickel finish |
| CWSHADE80NH | Ø 80cm, Height 90cm, Length steel cable 200cm, 18x G9, 35,0 kg, nickel finish |

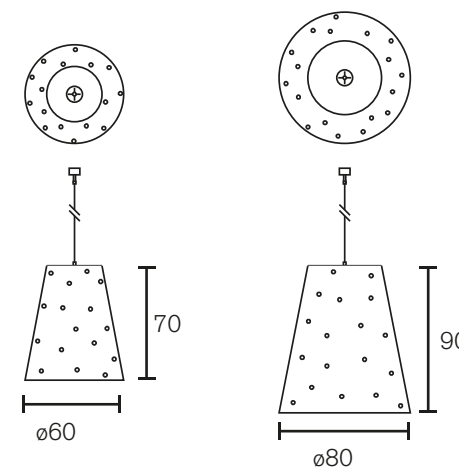

Hanging Lamp Drop

| Art.nr. | Dimensions CM |
|----------|--|
| CWH130NH | Ø 30cm, Height 130cm, Length steel cable 200cm, 14x G9, 9,0 kg, nickel finish |
| CWH160NH | Ø 35cm, Height 160cm, Length steel cable 200cm, 18x G9, 11,0 kg, nickel finish |
| CWH200NH | Ø 40cm, Height 200cm, Length steel cable 200cm, 24x G9, 15,0 kg, nickel finish |

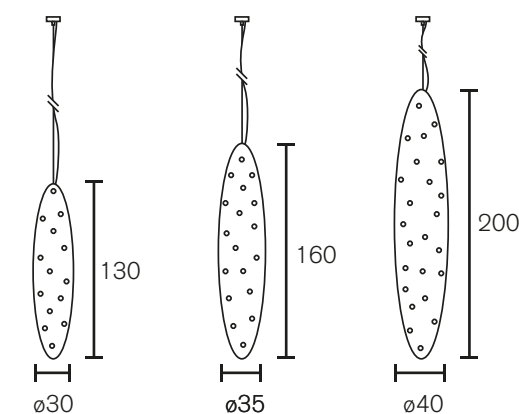

All hanging lamps are supplied with 2 meter electrical cable, 2 meter steel cable and a ceiling shade. All floor lamps are supplied with a dimmer.

Ceiling Lamp Round

| Art.nr. | Dimensions CM |
|----------|--|
| CWP40NH | Ø 40cm, Height 28cm, 7x G9, 4,0 kg, nickel finish |
| CWP60NH | Ø 60cm, Height 38cm, 10x G9, 5,0 kg, nickel finish |
| CWP80NH | Ø 80cm, Height 38cm, 13x G9, 10,0 kg, nickel finish |
| CWP100NH | Ø 100cm, Height 38cm, 16x G9, 12,0 kg, nickel finish |
| CWP120NH | Ø 120cm, Height 38cm, 17x G9, 16,0 kg, nickel finish |

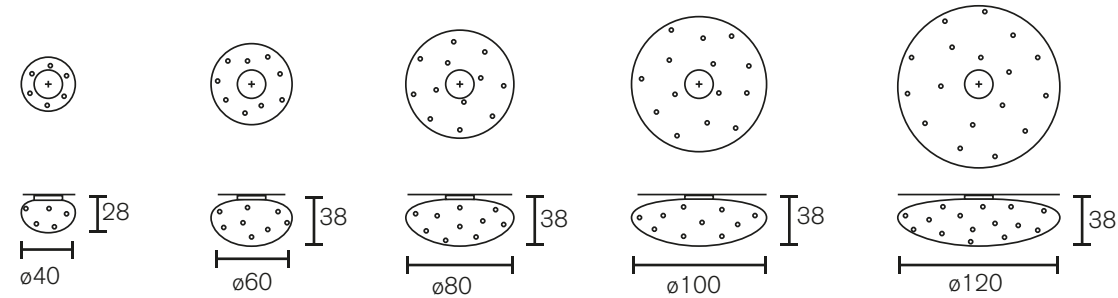

Floor Lamp

| Art.nr. | Dimensions CM |
|----------|--|
| CWF180NH | Ø 35cm, Height 185cm, 20x G9, 22,0 kg, nickel finish |

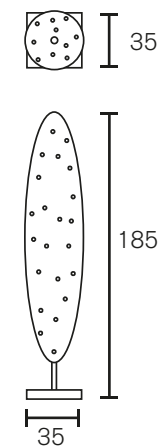

Wall Lamp

| Art.nr. | Dimensions CM |
|---------|--|
| 150CW1N | Width 20cm, Height 27cm, Depth 17cm, 1x E14, 3,0 kg, nickel finish |

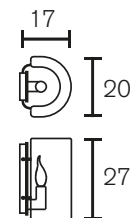

All hanging lamps are supplied with 2 meter electrical cable, 2 meter steel cable and a ceiling shade. All floor lamps are supplied with a dimmer.

Collection Delphinium 1998

Chandelier Round

| Art.nr. | Dimensions CM |
|---------|---|
| DC80N | Ø 80cm, Height 45cm, Length chain 170cm, 10x E14, 21,0 kg, nickel finish |
| DC100N | Ø 100cm, Height 55cm, Length chain 170cm, 12x E14, 27,0 kg, nickel finish |
| DC120N | Ø 120cm, Height 70cm, Length chain 170cm, 16x E14, 35,0 kg, nickel finish |
| DC140N | Ø 140cm, Height 70cm, Length chain 170cm, 20x E14, 67,0 kg, nickel finish |

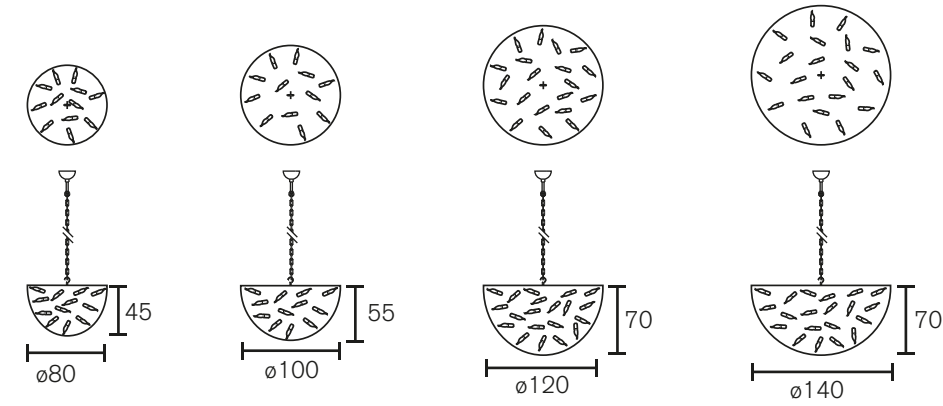

Chandelier Conical

| Art.nr. | Dimensions CM |
|---------|--|
| DCC60N | Ø 60cm, Height 70cm, Length chain 170cm, 8x E14, 20,0 kg, nickel finish |
| DCC70N | Ø 70cm, Height 80cm, Length chain 170cm, 10x E14, 25,0 kg, nickel finish |

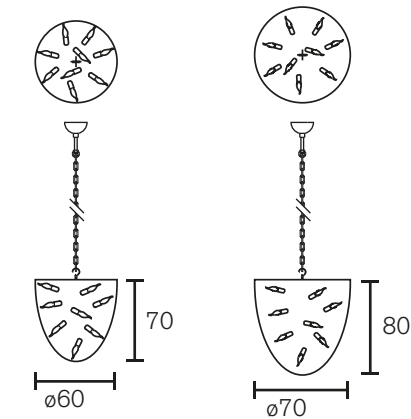

Chandelier Oval

| Art.nr. | Dimensions CM |
|---------|--|
| DOC60N | Length 120cm, Width 60cm, Height 55cm, Length chain 170cm, 12x E14, 27,0 kg, nickel finish |
| DOC70N | Length 140cm, Width 70cm, Height 55cm, Length chain 170cm, 12x E14, 29,0 kg, nickel finish |
| DOC80N | Length 160cm, Width 70cm, Height 55cm, Length chain 170cm, 16x E14, 40,0 kg, nickel finish |
| DOC100N | Length 200cm, Width 70cm, Height 70cm, Length chain 170cm, 20x E14, 58,0 kg, nickel finish |

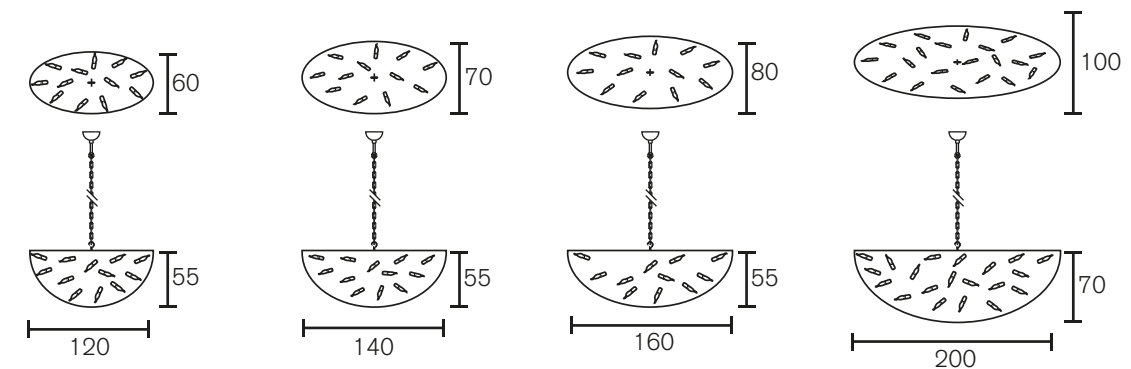

All chandeliers are supplied with 1,7 meter chain, 2 meter electrical cable and a ceiling shade. All floor- and table lamps are supplied with a dimmer.

Ceiling Lamp Round

| Art.nr. | Dimensions CM |
|---------|---|
| DP60N | Ø 60cm, Height 30cm, 5x E14, 11,0 kg, nickel finish |
| DP80N | Ø 80cm, Height 35cm, 6x E14, 17,0 kg, nickel finish |
| DP100N | Ø 100cm, Height 40cm, 8x E14, 26,0 kg, nickel finish |
| DP120N | Ø 120cm, Height 40cm, 10x E14, 40,0 kg, nickel finish |

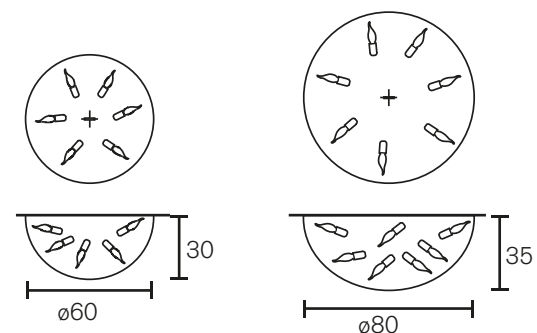
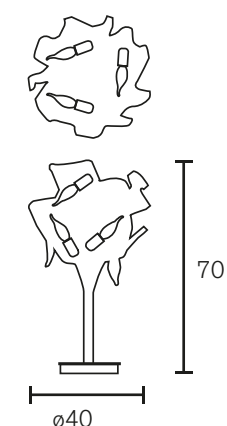

Table Lamp

| Art.nr. | Dimensions CM |
|---------|---|
| DT40ST | Ø 40cm, Height 70cm, 3x E14, 10,0 kg, stainless steel |



Wall Lamp

| Art.nr. | Dimensions CM |
|---------|---|
| DW20N-L | Width 13cm, Height 40cm, Depth 10cm, 1x E14, 3,0 kg, nickel finish, left version |
| DW20N-R | Width 13cm, Height 40cm, Depth 10cm, 1x E14, 3,0 kg, nickel finish, right version |
| DW35N | Width 40cm, Height 75cm, Depth 20cm, 3x E14, 7,0 kg, nickel finish |

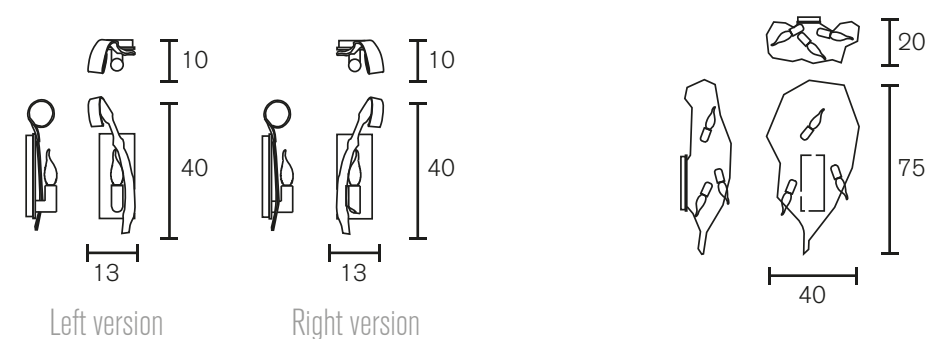

All chandeliers are supplied with 1,7 meter chain, 2 meter electrical cable and a ceiling shade. All floor- and table lamps are supplied with a dimmer.

Collection Hollywood 1996

Hanging Lamp InLine

| Art.nr. | Dimensions CM |
|-----------|---|
| HH25N | Ø 25cm, Height 30cm, Length steel cable 200cm, 1x E27, 4,0 kg, nickel finish, single piece |
| HH25N-3IL | Length 90cm, Width 25cm, Height 30cm, Length steel cable 200cm, 3x E27, 34,0 kg, nickel finish |
| HH25N-4IL | Length 145cm, Width 25cm, Height 30cm, Length steel cable 200cm, 4x E27, 37,0 kg, nickel finish |
| HH25N-5IL | Length 190cm, Width 25cm, Height 30cm, Length steel cable 200cm, 5x E27, 40,0 kg, nickel finish |
| HH25N-6IL | Length 235cm, Width 25cm, Height 30cm, Length steel cable 200cm, 6x E27, 43,0 kg, nickel finish |

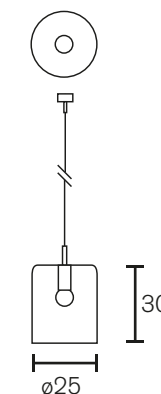

Hanging Lamp Long

| Art.nr. | Dimensions CM |
|---------|---|
| HHL100W | Length 100cm, Width 25cm, Height 30cm, Length steel cable 200cm, 4x E27, 13,0 kg, white finish |
| HHL100N | Length 100cm, Width 25cm, Height 30cm, Length steel cable 200cm, 4x E27, 13,0 kg, nickel finish |
| HHL125W | Length 125cm, Width 25cm, Height 30cm, Length steel cable 200cm, 5x E27, 18,0 kg, white finish |
| HHL125N | Length 125cm, Width 25cm, Height 30cm, Length steel cable 200cm, 5x E27, 18,0 kg, nickel finish |
| HHL150W | Length 150cm, Width 25cm, Height 30cm, Length steel cable 200cm, 6x E27, 18,0 kg, white finish |
| HHL150N | Length 150cm, Width 25cm, Height 30cm, Length steel cable 200cm, 6x E27, 18,0 kg, nickel finish |
| HHL175W | Length 175cm, Width 25cm, Height 30cm, Length steel cable 200cm, 7x E27, 21,0 kg, white finish |
| HHL175N | Length 175cm, Width 25cm, Height 30cm, Length steel cable 200cm, 7x E27, 21,0 kg, nickel finish |
| HHL200W | Length 200cm, Width 25cm, Height 30cm, Length steel cable 200cm, 8x E27, 25,0 kg, white finish |
| HHL200N | Length 200cm, Width 25cm, Height 30cm, Length steel cable 200cm, 8x E27, 25,0 kg, nickel finish |

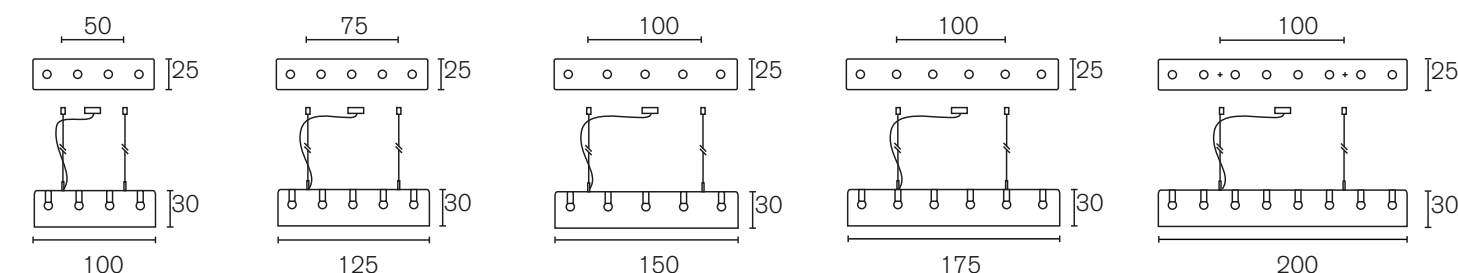

All hanging lamps are supplied with 1,7 meter chain, 2 meter electrical cable and a ceiling shade. The Hollywood Hanging Lamp Long is supplied with 2 small ceiling shades. Long ceiling shade with two steel cable connections available on request. All floor- and table lamps are supplied with a dimmer.

Hanging Lamp Block

| Art.nr. | Dimensions CM |
|---------|--|
| HCC50W | Length 40cm, Width 40cm, Height 50cm, Length chain 170cm, 1x E27, 13,0 kg, white finish |
| HCC50N | Length 40cm, Width 40cm, Height 50cm, Length chain 170cm, 1x E27, 13,0 kg, nickel finish |

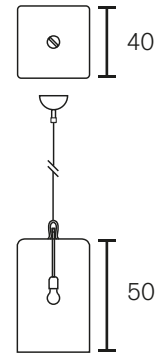

Chandelier Round

| Art.nr. | Dimensions CM |
|---------|---|
| HC80W | Ø 80cm, Height 25cm, Length chain 170cm, 6x E14, 11,0 kg, white finish |
| HC80N | Ø 80cm, Height 25cm, Length chain 170cm, 6x E14, 11,0 kg, nickel finish |
| HC100W | Ø 100cm, Height 25cm, Length chain 170cm, 8x E14, 25,0 kg, white finish |
| HC100N | Ø 100cm, Height 25cm, Length chain 170cm, 8x E14, 25,0 kg, nickel finish |
| HC120W | Ø 120cm, Height 25cm, Length chain 170cm, 10x E14, 28,0 kg, white finish |
| HC120N | Ø 120cm, Height 25cm, Length chain 170cm, 10x E14, 28,0 kg, nickel finish |

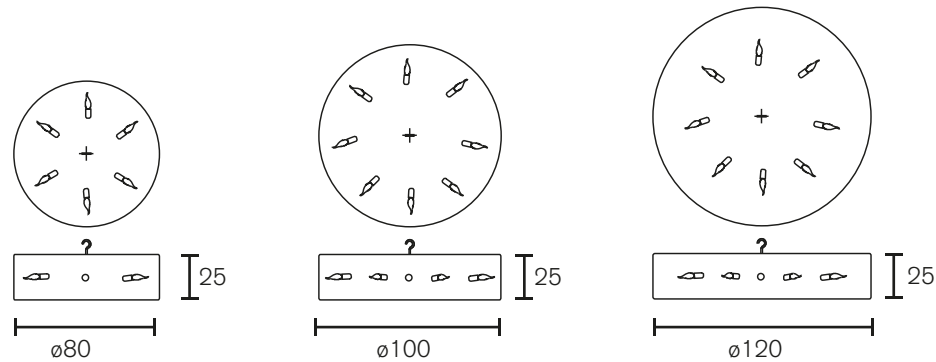

Chandelier Candlestick Round

| Art.nr. | Dimensions CM |
|------------|---|
| HCCH10X10W | Ø 100cm, Height 40cm, Length chain 170cm, 12x E14, 25,0 kg, white finish |
| HCCH10X10N | Ø 100cm, Height 40cm, Length chain 170cm, 12x E14, 25,0 kg, nickel finish |
| HCCH12X12W | Ø 120cm, Height 40cm, Length chain 170cm, 12x E14, 25,0 kg, white finish |
| HCCH12X12N | Ø 120cm, Height 40cm, Length chain 170cm, 12x E14, 25,0 kg, nickel finish |

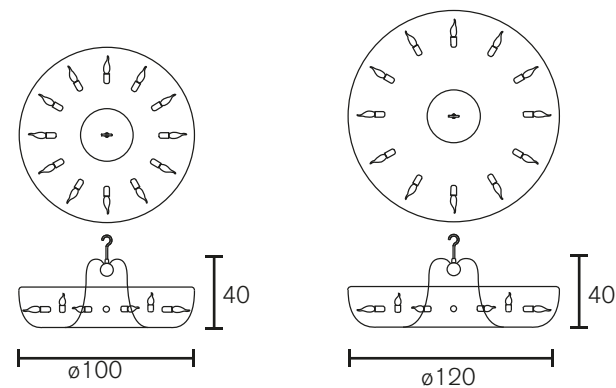

All hanging lamps are supplied with 1,7 meter chain, 2 meter electrical cable and a ceiling shade. The Hollywood Hanging Lamp Long is supplied with 2 small ceiling shades. Long ceiling shade with two steel cable connections available on request. All floor- and table lamps are supplied with a dimmer.

Chandelier Oval

| Art.nr. | Dimensions CM |
|---------|---|
| HOC60W | Length 120cm, Width 60cm, Height 25cm, Length chain 170cm, 8x E14, 13,0 kg, white finish |
| HOC60N | Length 120cm, Width 60cm, Height 25cm, Length chain 170cm, 8x E14, 13,0 kg, nickel finish |
| HOC70W | Length 140cm, Width 70cm, Height 25cm, Length chain 170cm, 8x E14, 17,0 kg, white finish |
| HOC70N | Length 140cm, Width 70cm, Height 25cm, Length chain 170cm, 8x E14, 17,0 kg, nickel finish |
| HOC80W | Length 160cm, Width 80cm, Height 25cm, Length chain 170cm, 8x E14, 24,0 kg, white finish |
| HOC80N | Length 160cm, Width 80cm, Height 25cm, Length chain 170cm, 8x E14, 24,0 kg, nickel finish |
| HOC100W | Length 200cm, Width 100cm, Height 25cm, Length chain 170cm, 12x E14, 38,0 kg, white finish |
| HOC100N | Length 200cm, Width 100cm, Height 25cm, Length chain 170cm, 12x E14, 38,0 kg, nickel finish |

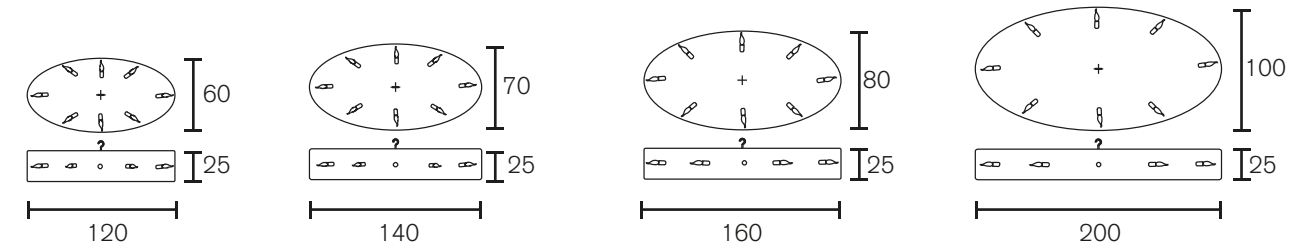

Chandelier Conical

| Art.nr. | Dimensions CM |
|---------|---|
| HCC40W | Ø 40cm, Height 60cm, Length chain 170cm, 6x E14, 6,0 kg, white finish |
| HCC40N | Ø 40cm, Height 60cm, Length chain 170cm, 6x E14, 6,0 kg, nickel finish |
| HCC60W | Ø 60cm, Height 100cm, Length chain 170cm, 8x E14, 16,0 kg, white finish |
| HCC60N | Ø 60cm, Height 100cm, Length chain 170cm, 8x E14, 16,0 kg, nickel finish |
| HCC90W | Ø 90cm, Height 130cm, Length chain 170cm, 16x E14, 27,0 kg, white finish |
| HCC90N | Ø 90cm, Height 130cm, Length chain 170cm, 16x E14, 27,0 kg, nickel finish |

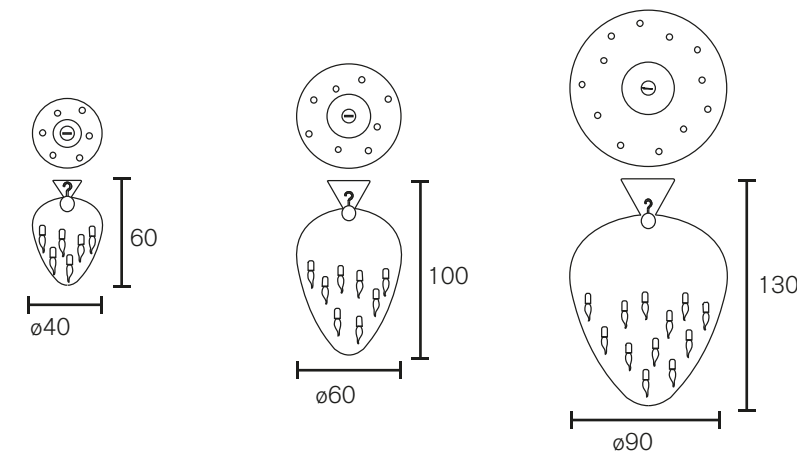

All hanging lamps are supplied with 1,7 meter chain, 2 meter electrical cable and a ceiling shade. The Hollywood Hanging Lamp Long is supplied with 2 small ceiling shades. Long ceiling shade with two steel cable connections available on request. All floor- and table lamps are supplied with a dimmer.

Chandelier Conical Oval

| Art.nr. | Dimensions CM |
|----------|--|
| HCCO120W | Length 120cm, Width 55cm, Height 75cm, Length chain 170cm, 12x E14, 23,0 kg, white finish |
| HCCO120N | Length 120cm, Width 55cm, Height 75cm, Length chain 170cm, 12x E14, 23,0 kg, nickel finish |
| HCCO140W | Length 140cm, Width 55cm, Height 85cm, Length chain 170cm, 14x E14, 26,0 kg, white finish |
| HCCO140N | Length 140cm, Width 55cm, Height 85cm, Length chain 170cm, 14x E14, 26,0 kg, nickel finish |
| HCCO160W | Length 160cm, Width 55cm, Height 85cm, Length chain 170cm, 14x E14, 30,0 kg, white finish |
| HCCO160N | Length 160cm, Width 55cm, Height 85cm, Length chain 170cm, 14x E14, 30,0 kg, nickel finish |

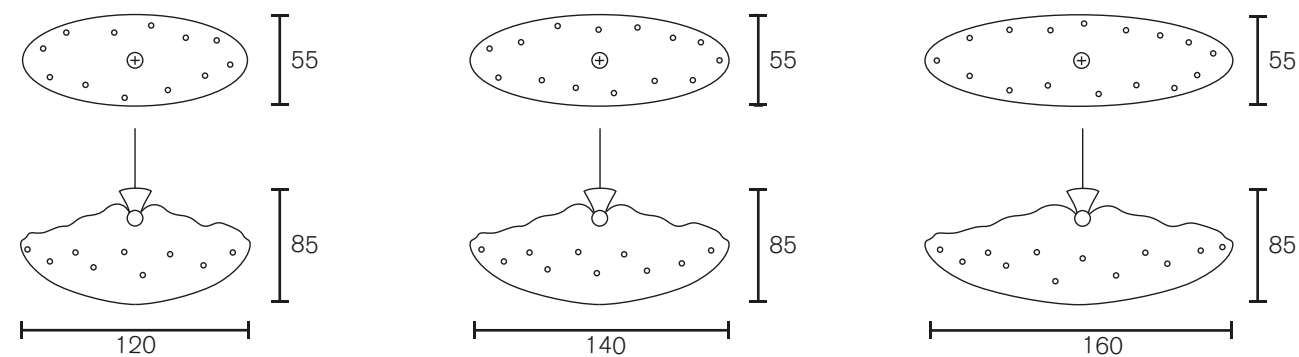

Ceiling Chandelier

| Art.nr. | Dimensions CM |
|---------|---|
| HPH40W | Ø 40cm, Height 40cm, 6x E14, 5,0 kg, white finish |
| HPH40N | Ø 40cm, Height 40cm, 6x E14, 5,0 kg, nickel finish |
| HPH60W | Ø 60cm, Height 60cm, 10x E14, 8,0 kg, white finish |
| HPH60N | Ø 60cm, Height 60cm, 10x E14, 8,0 kg, nickel finish |
| HPH80W | Ø 80cm, Height 80cm, 12x E14, 11,0 kg, white finish |
| HPH80N | Ø 80cm, Height 80cm, 12x E14, 11,0 kg, nickel finish |
| HPH100W | Ø 100cm, Height 80cm, 14x E14, 15,0 kg, white finish |
| HPH100N | Ø 100cm, Height 80cm, 14x E14, 15,0 kg, nickel finish |
| HPH120W | Ø 120cm, Height 80cm, 14x E14, 17,0 kg, white finish |
| HPH120N | Ø 120cm, Height 80cm, 14x E14, 17,0 kg, nickel finish |

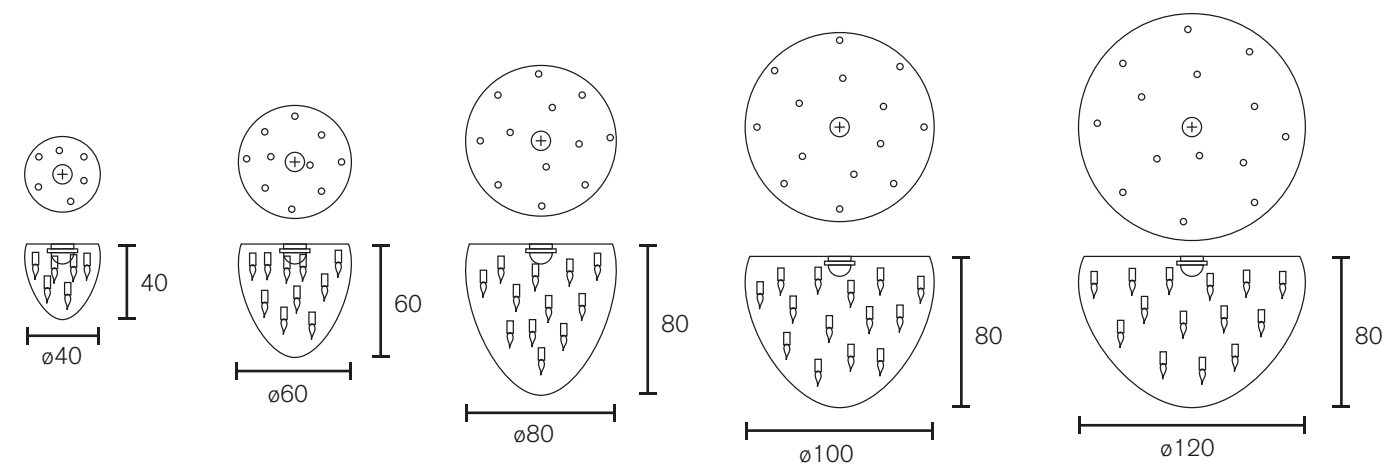

All hanging lamps are supplied with 1,7 meter chain, 2 meter electrical cable and a ceiling shade. The Hollywood Hanging Lamp Long is supplied with 2 small ceiling shades. Long ceiling shade with two steel cable connections available on request. All floor- and table lamps are supplied with a dimmer.

Ceiling Lamp Round

| Art.nr. | Dimensions CM |
|---------|---|
| HP40NH | Ø 40cm, Height 25cm, 6x G9, 3,0 kg, nickel finish |
| HP60W | Ø 60cm, Height 25cm, 6x E14, 6,0 kg, white finish |
| HP60N | Ø 60cm, Height 25cm, 6x E14, 6,0 kg, nickel finish |
| HP80W | Ø 80cm, Height 25cm, 6x E14, 10,0 kg, white finish |
| HP80N | Ø 80cm, Height 25cm, 6x E14, 10,0 kg, nickel finish |
| HP100W | Ø 100cm, Height 25cm, 8x E14, 16,0 kg, white finish |
| HP100N | Ø 100cm, Height 25cm, 8x E14, 16,0 kg, nickel finish |
| HP120W | Ø 120cm, Height 25cm, 10x E14, 24,0 kg, white finish |
| HP120N | Ø 120cm, Height 25cm, 10x E14, 24,0 kg, nickel finish |

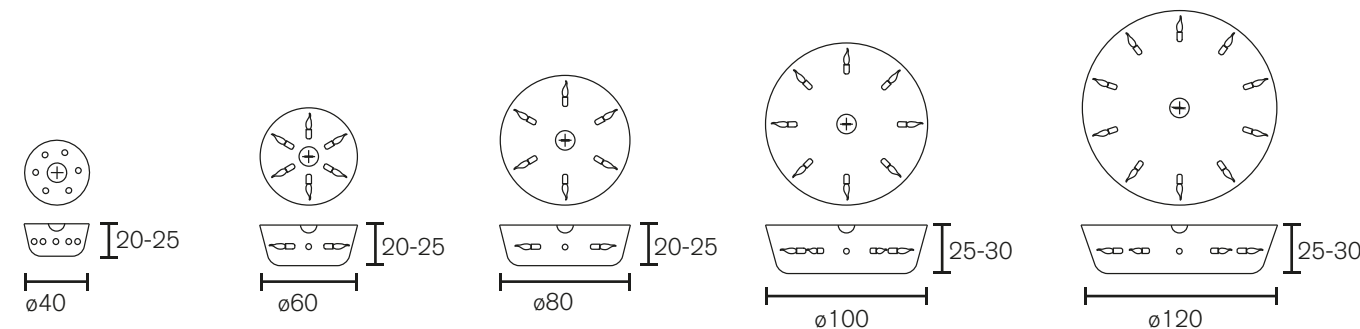

Wall Lamp

| Art.nr. | Dimensions CM |
|---------|---|
| HW20W-L | Width 20cm, Height 45cm, Depth 15cm, 1x E14, 1,0 kg, white finish, left version |
| HW20W-R | Width 20cm, Height 45cm, Depth 15cm, 1x E14, 1,0 kg, white finish, right version |
| HW20N-L | Width 20cm, Height 45cm, Depth 15cm, 1x E14, 1,0 kg, nickel finish, left version |
| HW20N-R | Width 20cm, Height 45cm, Depth 15cm, 1x E14, 1,0 kg, nickel finish, right version |
| HW30W-L | Width 30cm, Height 50cm, Depth 15cm, 1x E14, 2,0 kg, white finish, left version |
| HW30W-R | Width 30cm, Height 50cm, Depth 15cm, 1x E14, 2,0 kg, white finish, right version |
| HW30N-L | Width 30cm, Height 50cm, Depth 15cm, 1x E14, 2,0 kg, nickel finish, left version |
| HW30N-R | Width 30cm, Height 50cm, Depth 15cm, 1x E14, 2,0 kg, nickel finish, right version |

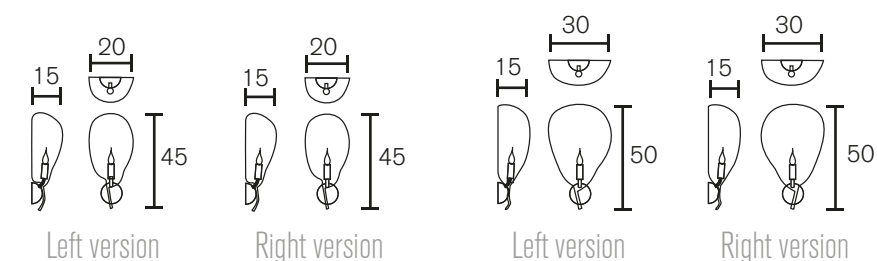

Wall Lamp Block

| Art.nr. | Dimensions CM |
|---------|--|
| HW45N | Width 20cm, Height 45cm, Depth 25cm, 1x E27, 6,0 kg, nickel finish |

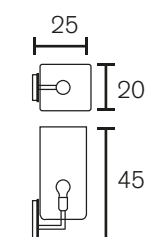

All hanging lamps are supplied with 1,7 meter chain, 2 meter electrical cable and a ceiling shade. The Hollywood Hanging Lamp Long is supplied with 2 small ceiling shades. Long ceiling shade with two steel cable connections available on request. All floor- and table lamps are supplied with a dimmer.

Table Lamp Block

| Art.nr. | Dimensions CM |
|---------|--|
| HT55W | Length 20cm, Width 20cm, Height 55cm, 1x E27, 6,5 kg, white finish |
| HT55N | Length 20cm, Width 20cm, Height 55cm, 1x E27, 6,5 kg, nickel finish |
| HT70W | Length 30cm, Width 30cm, Height 70cm, 1x E27, 14,0 kg, white finish |
| HT70N | Length 30cm, Width 30cm, Height 70cm, 1x E27, 14,0 kg, nickel finish |

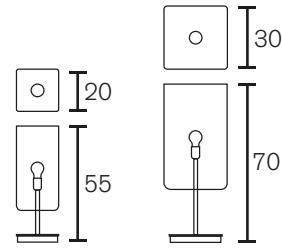

Floor Lamp Block

| Art.nr. | Dimensions CM |
|---------|---|
| HF170W | Length 30cm, Width 30cm, Height 170cm, 1x E27, 18,0 kg, white finish |
| HF170N | Length 30cm, Width 30cm, Height 170cm, 1x E27, 18,0 kg, nickel finish |
| HF190W | Length 40cm, Width 40cm, Height 190cm, 1x E27, 23,0 kg, white finish |
| HF190N | Length 40cm, Width 40cm, Height 190cm, 1x E27, 23,0 kg, nickel finish |

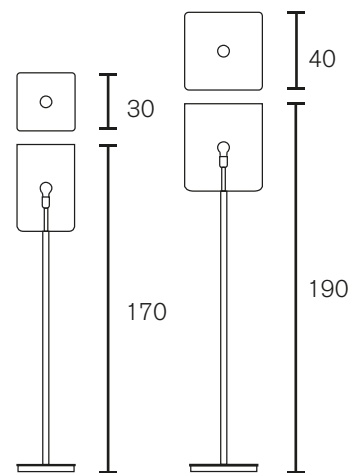

All hanging lamps are supplied with 1,7 meter chain, 2 meter electrical cable and a ceiling shade. The Hollywood Hanging Lamp Long is supplied with 2 small ceiling shades. Long ceiling shade with two steel cable connections available on request. All floor- and table lamps are supplied with a dimmer.

Collection Hollywood Glass

Chandelier Conical Glass

| Art.nr. | Dimensions CM |
|------------|--|
| HCCGL60BL | Ø 60cm, Height 75cm, Length chain 170cm, 8x E14, 16,0 kg, black finish |
| HCCGL60W | Ø 60cm, Height 75cm, Length chain 170cm, 8x E14, 16,0 kg, white finish |
| HCCGL60N | Ø 60cm, Height 75cm, Length chain 170cm, 8x E14, 16,0 kg, nickel finish |
| HCCGL80BL | Ø 80cm, Height 100cm, Length chain 170cm, 12x E14, 33,0 kg, black finish |
| HCCGL80W | Ø 80cm, Height 100cm, Length chain 170cm, 12x E14, 33,0 kg, white finish |
| HCCGL80N | Ø 80cm, Height 100cm, Length chain 170cm, 12x E14, 33,0 kg, nickel finish |
| HCCGL100BL | Ø 100cm, Height 125cm, Length chain 170cm, 16x E14, 44,0 kg, black finish |
| HCCGL100W | Ø 100cm, Height 125cm, Length chain 170cm, 16x E14, 44,0 kg, white finish |
| HCCGL100N | Ø 100cm, Height 125cm, Length chain 170cm, 16x E14, 44,0 kg, nickel finish |
| HCCGL120BL | Ø 120cm, Height 150cm, Length chain 170cm, 14x E14, 57,0 kg, black finish |
| HCCGL120W | Ø 120cm, Height 150cm, Length chain 170cm, 14x E14, 57,0 kg, white finish |
| HCCGL120N | Ø 120cm, Height 150cm, Length chain 170cm, 14x E14, 57,0 kg, nikkel finish |

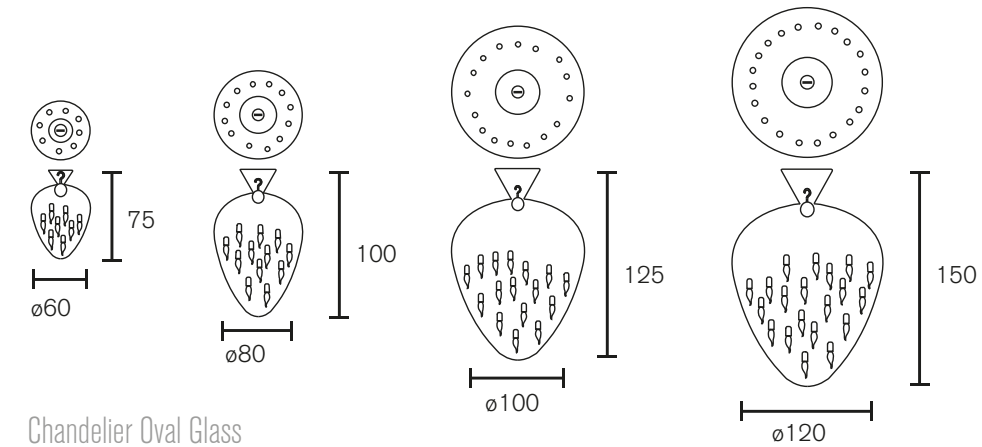

Chandelier Oval Glass

| Art.nr. | Dimensions CM |
|------------|--|
| HOCGL120BL | Length 120cm, Width 55cm, Height 85cm, Length chain 170cm, 12x E14, 32,0 kg, black finish |
| HOCGL120W | Length 120cm, Width 55cm, Height 85cm, Length chain 170cm, 12x E14, 32,0 kg, white finish |
| HOCGL120N | Length 120cm, Width 55cm, Height 85cm, Length chain 170cm, 12x E14, 32,0 kg, nickel finish |
| HOCGL140BL | Length 140cm, Width 55cm, Height 85cm, Length chain 170cm, 14x E14, 37,0 kg, black finish |
| HOCGL140W | Length 140cm, Width 55cm, Height 85cm, Length chain 170cm, 14x E14, 37,0 kg, white finish |
| HOCGL140N | Length 140cm, Width 55cm, Height 85cm, Length chain 170cm, 14x E14, 37,0 kg, nickel finish |
| HOCGL160BL | Length 160cm, Width 55cm, Height 85cm, Length chain 170cm, 16x E14, 49,0 kg, black finish |
| HOCGL160W | Length 160cm, Width 55cm, Height 85cm, Length chain 170cm, 16x E14, 49,0 kg, white finish |
| HOCGL160N | Length 160cm, Width 55cm, Height 85cm, Length chain 170cm, 16x E14, 49,0 kg, nickel finish |

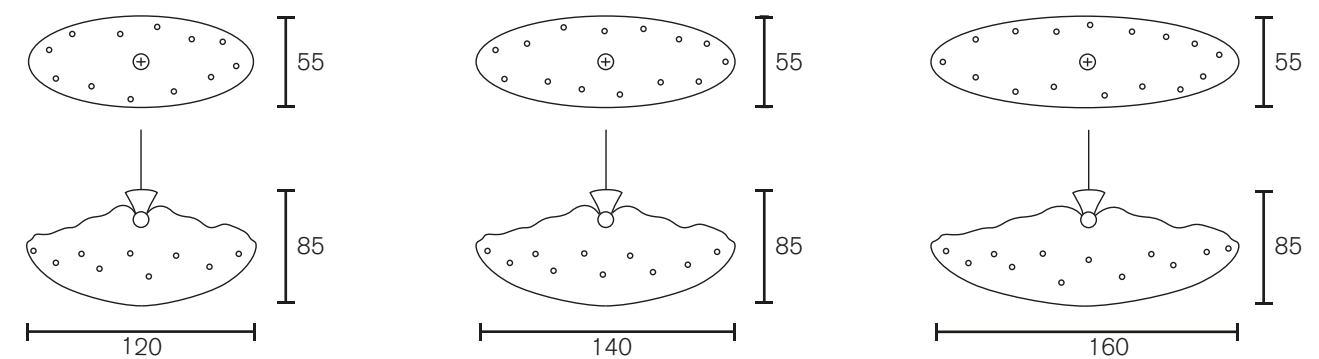

All hanging lamps are supplied with 1,7 meter chain, 2 meter electrical cable and a ceiling shade. The Hollywood Hanging Lamp Long is supplied with 2 small ceiling shades. Long ceiling shade with two steel cable connections available on request. All floor- and table lamps are supplied with a dimmer.

Ceiling Chandelier Glass

| Art.nr. | Dimensions CM | Price |
|----------|---|---------|
| HPGL40N | Ø 40cm, Height 45cm, 6x E14, 15,0 kg, nickel finish | € 3.245 |
| HPGL60N | Ø 60cm, Height 50cm, 8x E14, 22,0 kg, nickel finish | € 3.786 |
| HPGL80N | Ø 80cm, Height 55cm, 11x E14, 28,0 kg, nickel finish | € 4.532 |
| HPGL100N | Ø 100cm, Height 60cm, 14x E14, 42,0 kg, nickel finish | € 5.408 |
| HPGL120N | Ø 120cm, Height 65cm, 15x E14, 60,0 kg, nickel finish | € 6.386 |

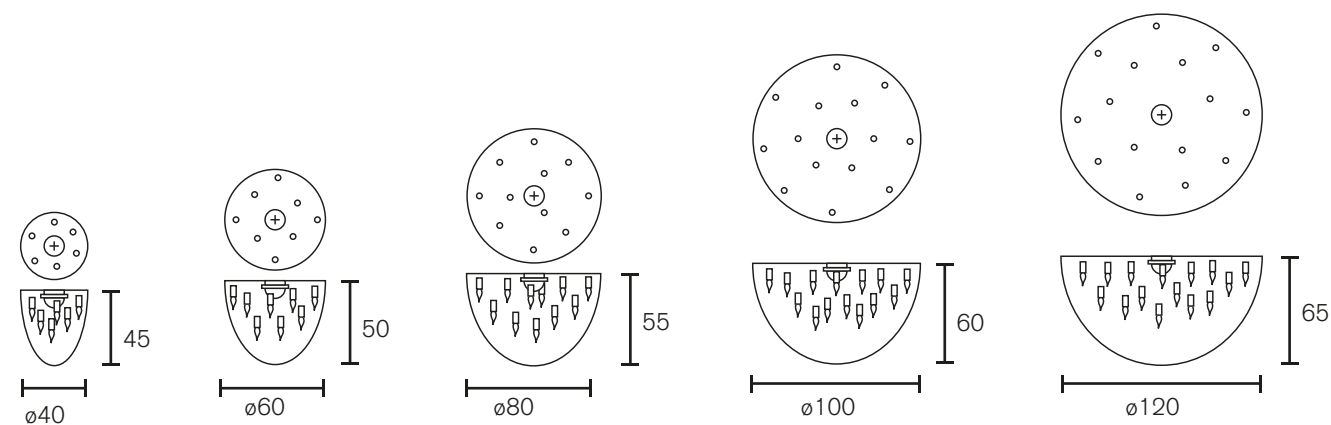

Ceiling Chandelier Glass High

| Art.nr. | Dimensions CM | Price |
|----------|--|---------|
| HPGLH60N | Ø 60cm, Height 60cm, 8x E14, 23,0 kg, nickel finish | € 4.028 |
| HPGLH80N | Ø 80cm, Height 80cm, 12x E14, 34,0 kg, nickel finish | € 4.876 |

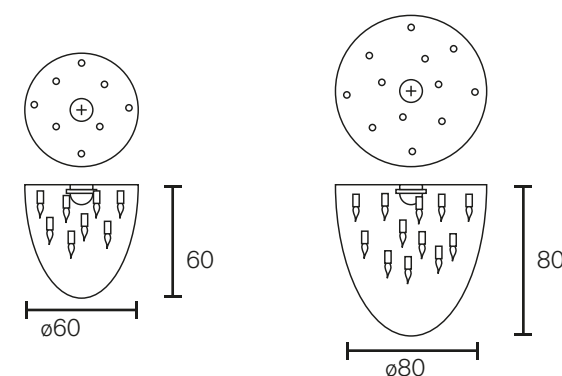

Colofon

BRAND VAN EGMOND

William Brand

Photography by

Alexander van Berge: pag. 143, 196, 206, 290, 169, 181, 193,

Billy Blanco Design: pag. 173,

Brigitte Kroone: pag. 53, 54, 55, 56, 61, 70, 82, 111, 112, 113, 118, 119, 120, 125, 126, 130, 131, 134, 135, 137, 139, 162, 171, 177, 189, 191, 195, 199, 200, 210, 211, 212, 219, 220

COSMOPOLITAN HOTEL: pag. 182

Daniel Nicolas: pag. 9, 10, 11, 13, 14, 15, 16, 17, 19, 21, 22, 23, 24, 25, 27, 28, 29, 30, 31, 33, 34, 35, 37, 38, 39, 40, 41, 43, 44, 45, 47, 48, 50, 51, 57, 58, 59, 63, 65, 66, 68, 69, 71, 72, 73, 75, 76, 77, 79, 80, 83, 84, 93, 94, 95, 106, 108, 109, 110, 115, 123, 127, 128, 133, 140, 141, 146, 148, 154, 157, 158, 159, 163, 165, 166, 167, 170, 174, 178, 183, 185, 187, 197, 201, 203, 205, 213, 214, 215, 217, 218, 223, 226, 227, 228, 229, 230, 233,

DAMAD LICHTSTUDIO: pag. 105, 180, 184

DESANGE SALON Moscow, RU: pag. 78

DESIGNA: pag. 91

GECO: pag. 205

Grey D'Albion: pag.138

H.N. Lin: pag. 129

La Cornue: pag. 179

LOUIS VUITTON: pag. 175

Marco Hamoen: pag. 102, 103, 114, 121, 153, 155, 161, 221,

Mark Groeneveld: pag. 4, 235

Ralf Buscher: pag. 192

Royal Dutch Embassy, Moscow: pag. 144

Schloss Hünigen Architecturburo HMS: pag. 208-209,

Hotel Brandenburger Hof, Berlin: pag. 145,

Tefaf Maastricht: pag. 224-225,

Van der Valk Hotel: pag. 164

Verlichting.be BVBA: pag. 89, 90

W Hotel: pag. 124

All hanging lamps are supplied with 1,7 meter chain, 2 meter electrical cable and a ceiling shade. The Hollywood Hanging Lamp Long is supplied with 2 small ceiling shades. Long ceiling shade with two steel cable connections available on request. All floor- and table lamps are supplied with a dimmer.

All rights reserved, copyright© Brand van Egmond B.V. © 2016 For all models, texts, layout and images. Specifications are subject to change without prior notice. Brand van Egmond manufactures exclusive lighting sculptures on a small scale. Because their products are handmade, they can differ from one another. Each product has its own identity and therefore is unique. Each item is labelled with its own number and seal. Brand van Egmond reserves the right to change their models from time to time without prior notice. The designs, texts, layout or pictures included in this brochure are protected by copyright and/or industrial design rights. No part there of may be made public, reproduced or amended in any form or in any manner whatsoever, for commercial purposes by third parties, including dealers, retailers, internet shops and others, without the prior and express written permission of the designer William Brand.



BRAND VAN EGMOND B.V. Nikkelstraat 41, 1411 AH Naarden, the Netherlands

 +31 (0)35 692 12 59

 +31 (0)35 691 17 25

 info@brandvanegmond.com

 www.brandvanegmond.com